

### Description

The F6212 is a 16-channel dual-beam receive active beamforming RFIC multi-chip module designed for application in Ka-Band SATCOM planar phased array antennas. The IC has eight RF input ports, two RF output ports, and 16 (8 per beam) phase/amplitude control channels. The eight input ports of the IC can be driven by eight single-polarized elements or four dual-polarized elements of an electronically scanned array (ESA). Each channel has 6 bits of digital phase and gain control resolution spanning 360° and 26dB of dynamic range, enabling precise beam pattern and polarization control.

The IC operates from two supply rails of 2.1 - 2.5V and 0.95 - 1.05V with a typical channel gain of 28dB. The chip includes power management features such as a low-power standby mode, independent enable controls on every channel, and a single-beam mode activated via a dedicated control pin. An integrated Hi-Q bandpass filter provides rejection of SATCOM Tx and 5G mmWave signals, improving the dynamic range without additional power consumption. The device SPI bus and control pins operate from standard 1.8V logic at speeds up to 50MHz. Advanced digital modes and large on-chip memory allow for < 100ns beam position switching times at the array level, greatly reducing dead time and latency.

Finally, the compact and CTE-matched FCBGA organic package with all single-ended 50ohm matched RF ports and 0.5mm pitch greatly simplifies the physical integration of these devices onto large antenna panels.

### Features

- 17.7 – 21.2GHz operation
- Supports 4 dual-pol or 8 single-pol elements
- Two simultaneous and independent beam outputs
- Integrated Hi-Q transmit reject filter
- 28dB typical channel gain
- 26dB gain control with 0.45dB step size
- 360° phase control with 6-bit resolution
- 2.3V and 1V nominal supply inputs
- Standard 1.8V digital logic
- Temperature compensation
- Temperature sensor w/ digital readout
- Advanced digital modes with fast beam steering
- On-chip beam-state memory
- 7.6 × 7.6 × 0.9 mm, 165-FCBGA

### Typical Applications

- Phased array antennas
- Ka-Band SATCOM terminals
- Aerospace, maritime, and SOTM

### Block Diagram

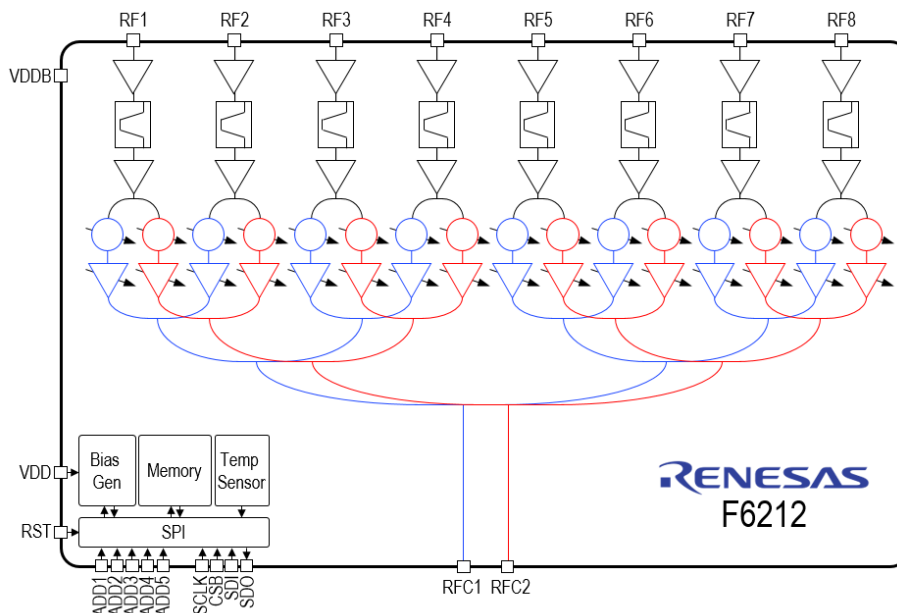

## Ordering Information

Orderable Part Number	Package	MSL Rating	Carrier Type	Temperature
F6212AVGI	7.6 × 7.6 × 0.9 mm 165-BGA	3	Tray	-40°C to +85°C
F6212AVGI8	7.6 × 7.6 × 0.9 mm 165-BGA	3	Reel	-40°C to +85°C
F6212EVS	F6212 Evaluation System. Includes Digital Interface Board, RF Evaluation Board, USB Cable, Power Supply Cable, Digital Interconnect Cable, Evaluation Software, Device Drivers and RF De-embed Files.			