

Features

- INPUT: 2 TO 9 GHz
- OUTPUT: 4 TO 18 GHz
- INPUT DRIVE LEVEL: +12 dBm (NOMINAL)
- HERMETICALLY-SEALED PACKAGE

Description

The FD93 is a passive bridge diode frequency doubler, designed for use in the high volume commercial and test equipment applications. The design utilizes Schottky bridge quad diodes and broadband baluns to attain excellent performance. The use of high temperature solder and welded assembly processes used internally makes it ideal for use in semi-automated and automated assembly. Environmental screening available to MIL-STD-883, MIL-STD-202, or MIL-DTL-28837, consult factory.

Ordering Information

Part Number	Package
FD93	Versapac
FD93C	SMA Connectorized

Product Image

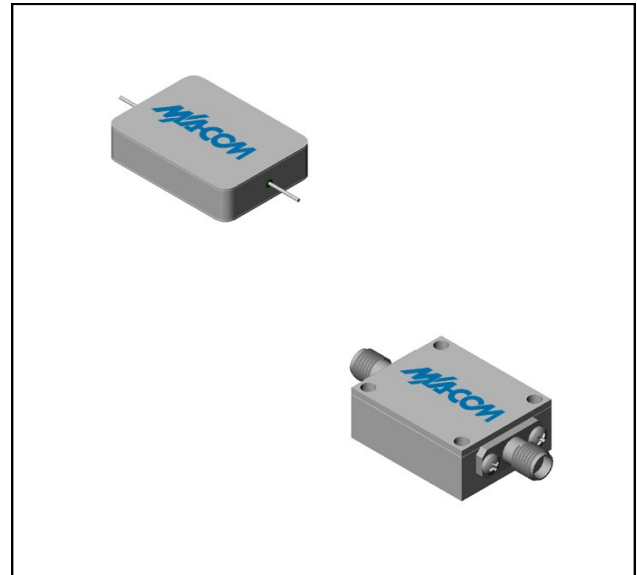

Electrical Specifications: $Z_0 = 50\Omega$ $P_{in} = +12$ dBm

Parameter	Test Conditions	Units	Typical	Guaranteed	
				+25°C	-54° to +85°C
SSB Conversion Loss (max)	$f_{in} = 2$ to 4 GHz	dB	10.0	13.0	13.5
	$f_{in} = 4$ to 9 GHz	dB	12.0	14.0	14.5
Fundamental Suppression (min)	$f_{in} = 2$ to 9 GHz	dBc	25	18	16
Third Harmonic Suppression	$f_{in} = 2$ to 6 GHz	dBc	25	17	15
Input VSWR	$f_{in} = 2$ to 9 GHz		1.5:1		

Typical Performance Curves

Conversion Loss vs. Input Power

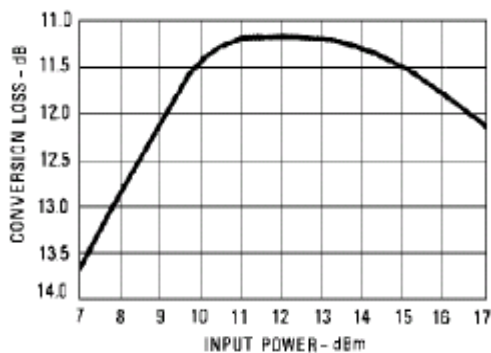

Input/Output Isolation

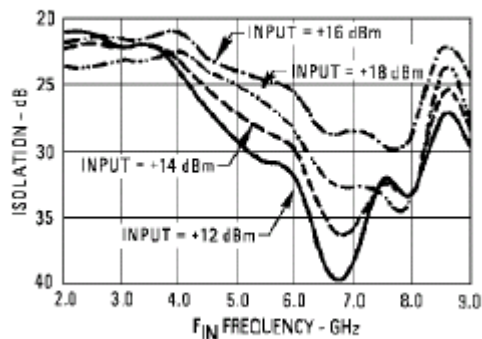

Suppression vs. Input Frequency

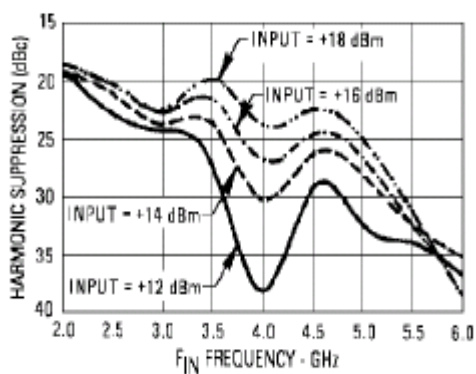

VSWR vs. Frequency

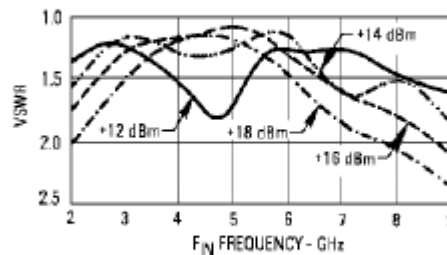

Conversion Loss vs. Input Frequency

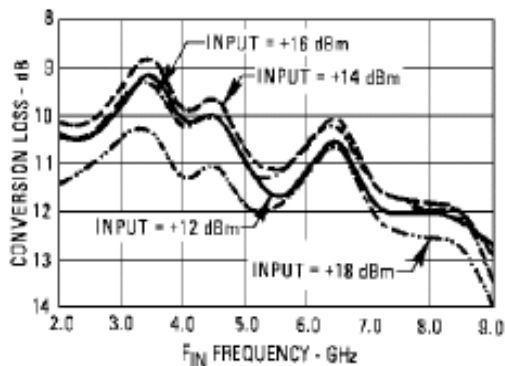

Absolute Maximum Ratings

Parameter	Absolute Maximum
Operating Temperature	-54°C to +100°C
Storage Temperature	-65°C to +100°C
Peak Input Power	+23 dBm max @ +25°C +20 dBm max @ +100°C

Outline Drawing: Versapac *

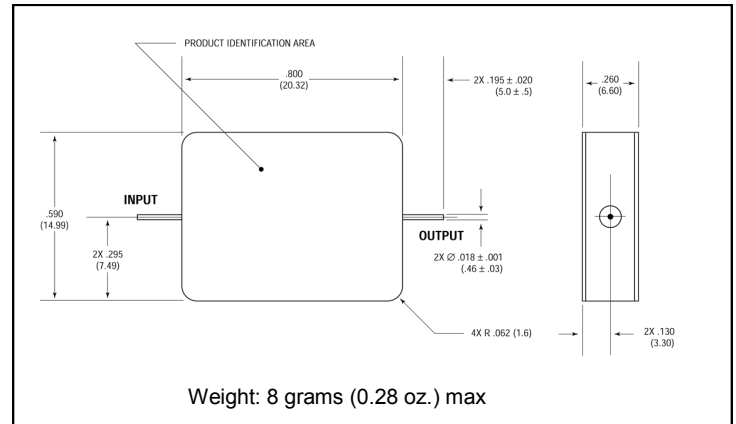

Outline Drawing: SMA Connectorized *

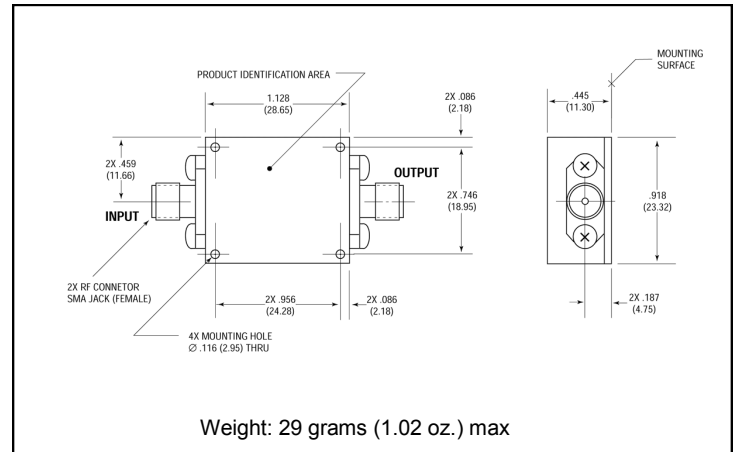

* Dimensions are inches (millimeters) ±0.015 (0.38) unless otherwise specified.