

Overview

The FG-R05-4A sensor is a high-sensitivity AC and DC leakage current sensor with individual open drain alarms and an analog output for leakage current indication. In addition, its integrated test coil can be initiated by a test input to perform a functional alarm test.

Applications

Typical applications include residual current sensor for In-Cable Control and Protection Devices (IC-CPD) or Wallbox.

Benefits

- Open-loop, fluxgate-based current sensor
- PCB mounting
- Digital output of fault detection
- Conforms to IEC 62752:2016/A1:2018
- Conforms to IEC 62955:2018 ¹
- Conforms to UL 2231-2
- RoHS compliant
- 3,000 A surge current capability



Ordering Information

FG-	R05-	4A
Series	Shape	Current Detection Standards
FG	R05 = Vertical	4A = IEC 62752:2016/A1:2018 and UL 2231-2, IEC 62955:2018 ¹

¹ Conditional and dependant on the circuit/system designed as explained in the section Recommended Circuit of this datasheet.

Dimensions in mm

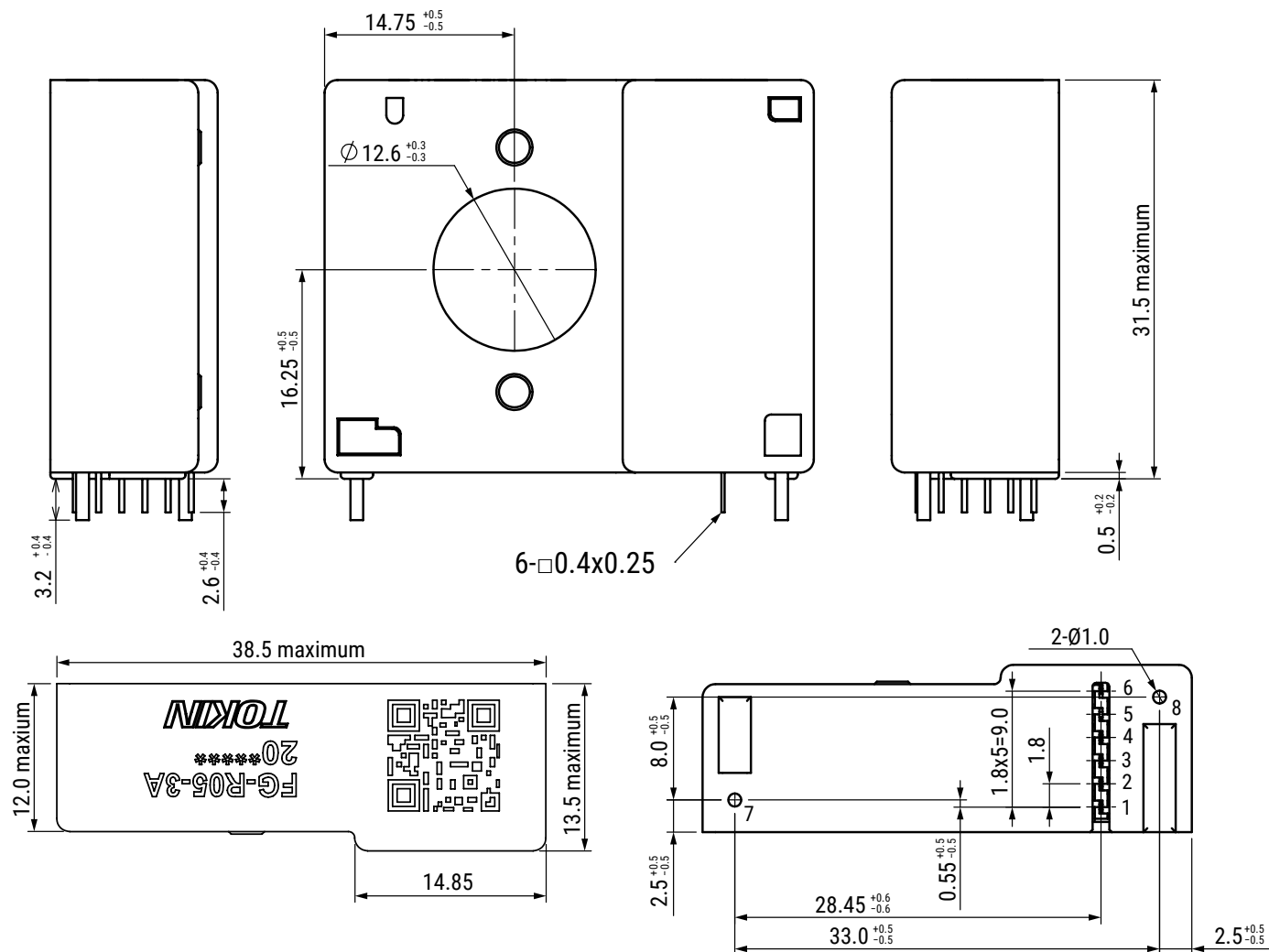

Pin Number	Symbol	Pin Type	Functions
1	VDD	Power	Power supply, 5 V
2	GND	Power	Ground
3	AOUT	Analog output	Analog output. This is for monitoring purposes, and is not safety function! Offset voltage is 2.25 V (typical). Sensitivity is 40 V/A (typical).
4	DC Alarm (Open-Drain)	Open drain	Active high if DC current is in the range of 3 to 6 mA.
5	AC Alarm (Open-Drain)	Open drain	Active high if AC current is in the range of 15 to 20 mA. IEC62752:2016 and UL 2231 (CCID20)
6	TEST	Input	Test input. Internal pull-down with 100 k Ω . Test sequence starts when input positive pulse input (>120 usec).

PCB Footprint - Top View

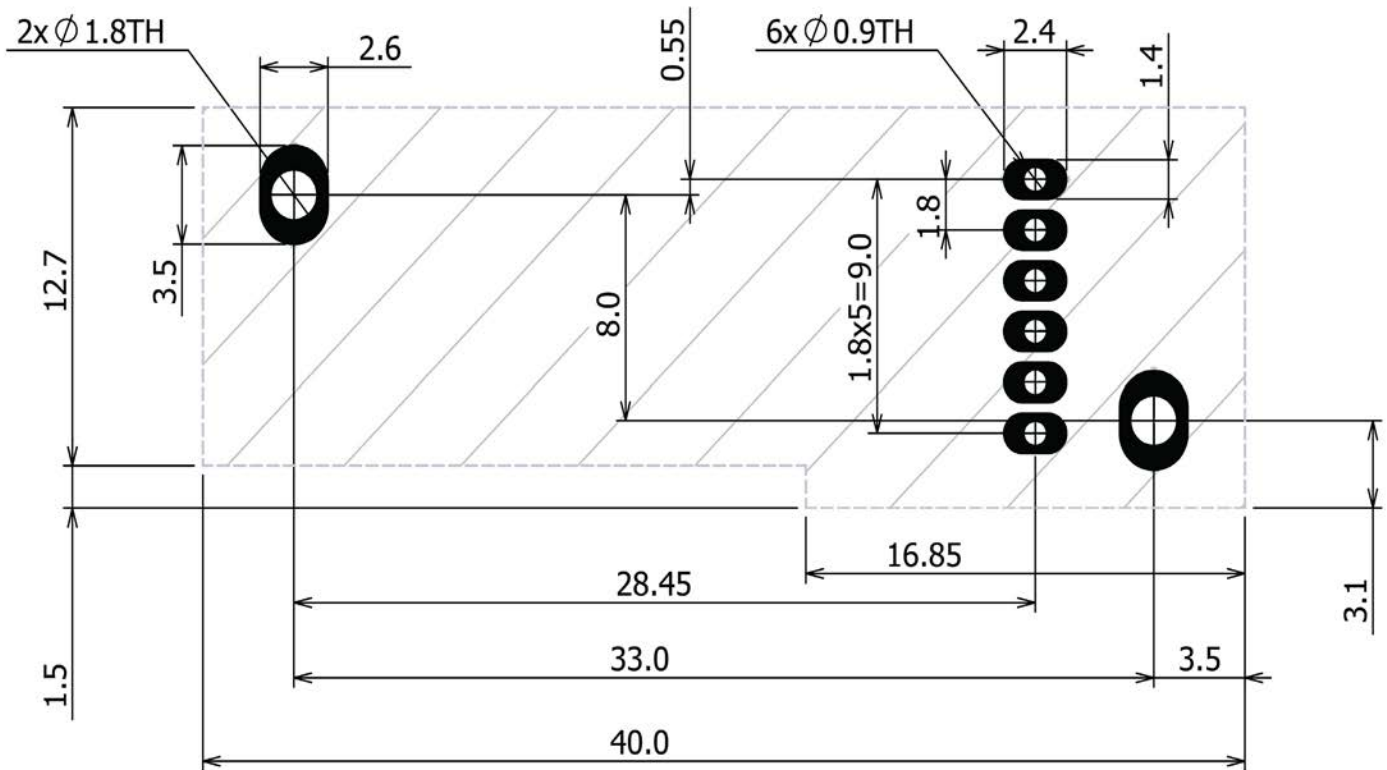

Output Characteristics

Switching Operation

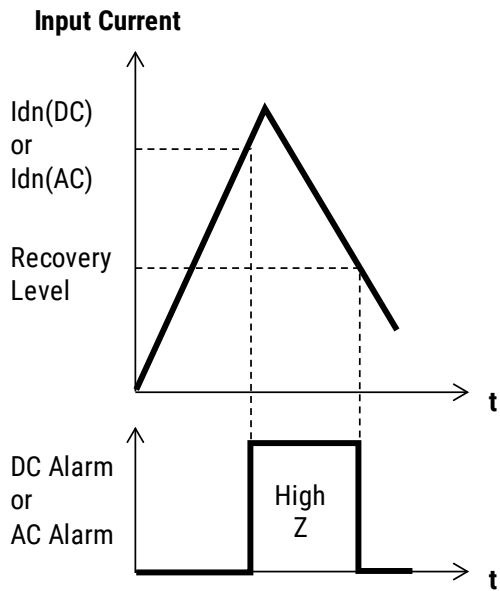

When the residual current exceeds the threshold level ($I_{dn}(DC)$ or $I_{dn}(AC)$), PIN 4 (DC Alarm) or PIN 5 (AC Alarm) will change from low level to high impedance. Each output goes back from high impedance to low level when residual current falls below recovery level.

PIN 3 Analog Output – DC Characteristics

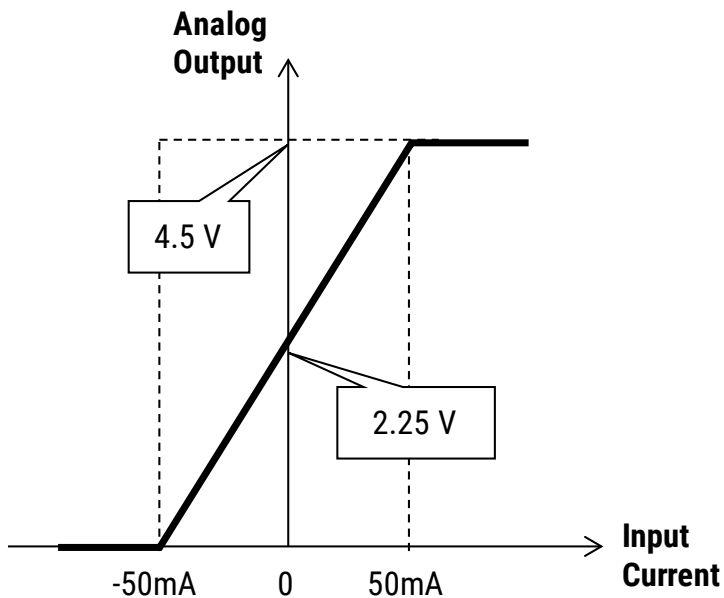

Output Characteristics (cont.)

Output State

DC Alarm	AC Alarm	State
GND	GND	Normal Condition
High Impedance	GND	DC Detection Current > 6 mA
GND	High Impedance	AC Detection Current > 20 mA
High Impedance	High Impedance	DC Detection Current > 6 mA and AC Detection Current > 20 mA

Temperature of primary wire should not exceed 105°C.
The rise time of the supply voltage is 50 μ s to 100 ms.

Frequency Characteristics of Analog Output

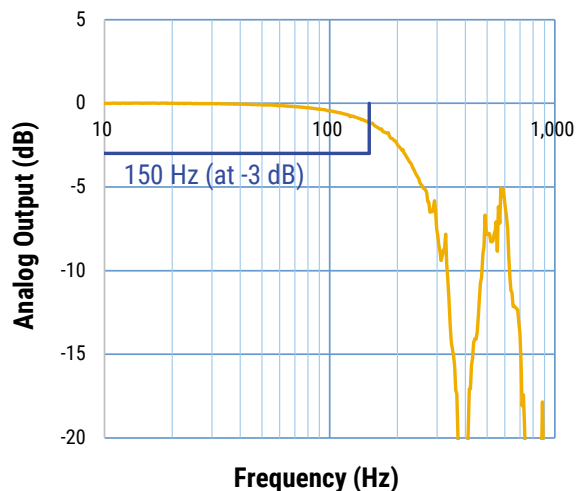

Frequency Characteristics of Response Value

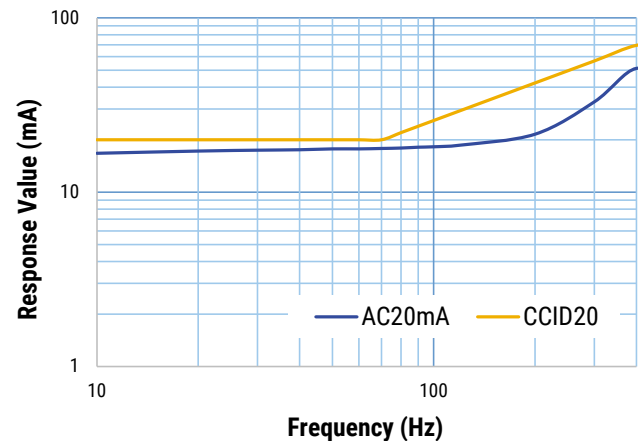

Trip Current of Pulsating DC at Phase 0°, 90°, 180°

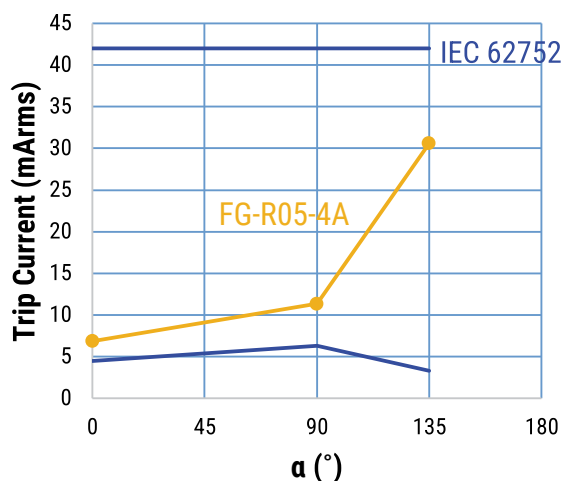

Trip Current of AC + DC

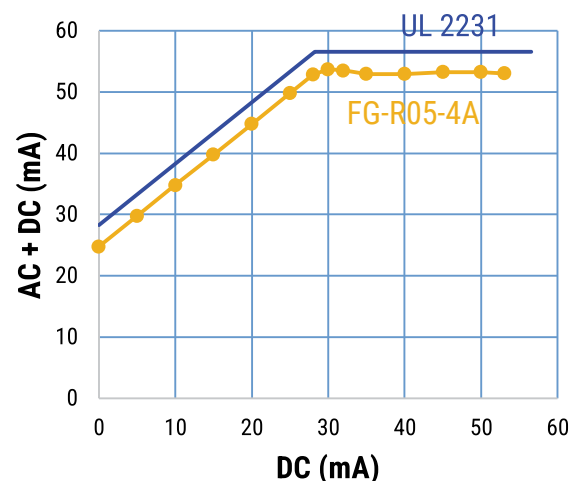

Above data are not guaranteed values, for reference only.

Environmental Compliance

FG sensors are RoHS compliant.



Specifications

Item	Performance Characteristics
Primary Rated Voltage	250 V
Primary Nominal Current	80/40 A Maximum (1 phase/3 phase)
Supply Voltage Range	4.75 – 5.25 V (5 V typical)
Maximum Input Voltage of Digital Output	Supply Voltage + 0.3 V
Input Voltage Range of TEST (LOW)	0.0 – 0.6 V
Input Voltage Range of TEST (HIGH)	2.5 V - Supply Voltage
Maximum Sink Current of Digital Output	10 mA
Current Consumption	13 mA (at measurement 0 mA)
Operating Temperature Range	-40°C to +105°C
Storage Temperature Range	-40°C to +105°C

Tests

ESD Test

DC Detection Current within specifications as per Table 1 – Ratings & Part Number Reference after ESD test.

Parameter	Result
Electrostatic Discharge Voltage Human-Body Model (HBM) R = 1,500 Ω, C = 100 pF, U = ±2,000 V	Passed
Electrostatic Discharge Voltage Charged-Device Model (CDM) U = ±800 V	Passed

Tests (cont.)

EMC Test

DC Alarm and AC Alarm do not malfunction during noise stimulation.

Parameter	Conditions	Result
IEC 61000-4-3 Radiated, radio-frequency, electromagnetic field immunity	20 V/m, 80 MHz – 1 GHz 80% AM 1 kHz	Passed
ISO 11452-2 (ALSE) Electrical disturbances from narrowband radiated electromagnetic energy	50 V/m 200 MHz – 800 MHz 80% AM 1 kHz, 800 MHz – 2 GHz PM	Passed
ISO 11452-4 (BCI) Electrical disturbances from narrowband radiated electromagnetic energy	100 mA 20 MHz – 200 MHz 80% AM 1 kHz	Passed
IEC 62955 § 9.18.2 Surge current immunity test	Peak 3,000 A Virtual front time 8 μ s Virtual time to half value 20 μ s	Passed

Dielectric Strength

Parameter	Conditions	Values
$U_{W, \text{prim-sec}}$	Impulse (1.2 μ s/50 μ s), PIN 1-6 vs insulated primary wire, 5 pulse -> polarity +, 5 pulse -> polarity -	5,500 V _{rms}
U_d	Test voltage, 60 seconds PIN 1-6 vs insulated primary wire	1,500 V _{rms}
$U_{PDx1.5}$	Partial discharge voltage, PIN 1-6 vs insulated primary wire * acc. to table 24	1,200 V _{rms}
$U_{PDx1.875}$	Partial discharge voltage, PIN 1-6 vs insulated primary wire * acc. to table 24	1,500 V _{rms}

* IEC 61800-5-1:2007

Table 1 – Ratings & Part Number Reference

Part Number	Measurement Range (mA)	DC Detection Current ¹ (mA)	AC Detection Current ^{1 2} (mArms)	DC Alarm Response Time (ms)	AC Alarm Response Time (ms)
FG-R05-4A	-50 - +50	4.5 typical 3 minimum 6 maximum	17.5 typical 15 minimum 20 maximum (at 55 Hz)	280 typical, 1,000 maximum (at measurement = 6 mA) 24 typical, 250 maximum (at measurement = 60 mA) 6 typical, 15 maximum (at measurement = 300 mA)	60 typical, 250 maximum (at measurement = 30 mArms) 20 typical, 100 maximum (at measurement = 60 mArms) 8 typical, 20 maximum (at measurement = 150 mArms) 7 typical, 10 maximum (at measurement = 264 mArms) 7 typical, 10 maximum (at measurement > 5 Arms)

¹ Recovery level = detection current/2.

² Frequency characteristic of AC detection current = -1% typical, -2% minimum at 45 Hz/55 Hz and +1% typical, +2% maximum at 65 Hz/55 Hz.

Table 1 – Ratings & Part Number Reference cont.

Part Number	PIN 3 AOUT Sensitivity (V/A)	PIN 3 AOUT Offset Voltage (V)	PIN 3 AOUT Frequency Range (Hz)	Hole Diameter (mm)	Weight (g)
FG-R05-4A	40 typical	2.25 typical	150 maximum (at -3 dB)	φ 12.6	20

Recommended Wire Configurations

In Case of Insulated Wire

Three phase system < 480 V

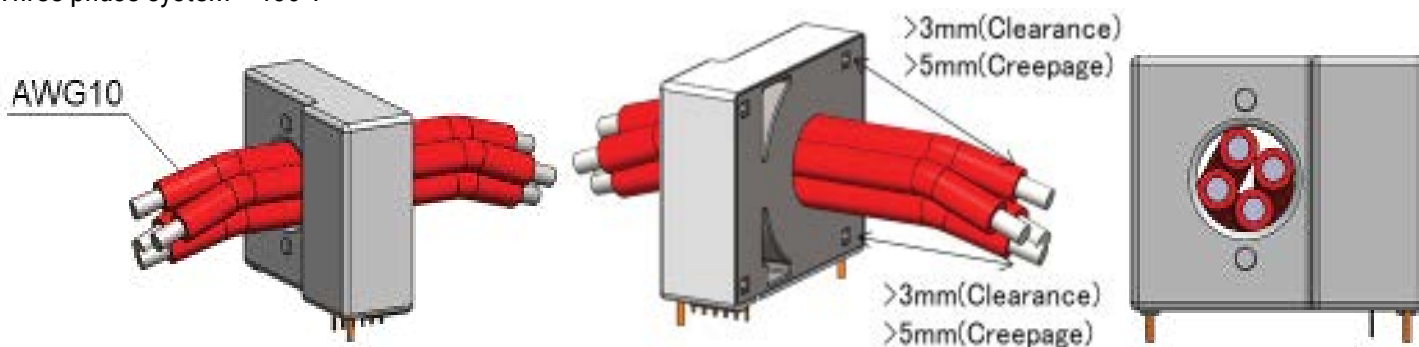

In Case of Bare Wire

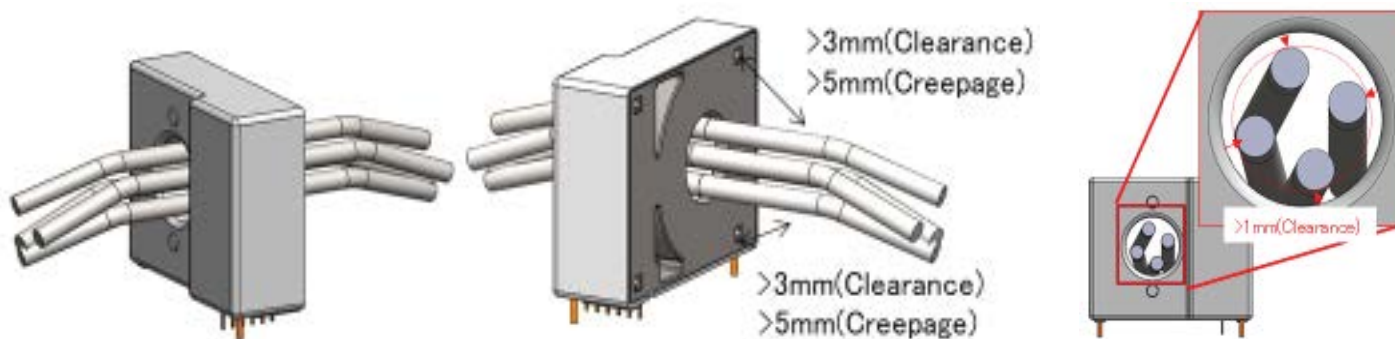

Reinforced insulation, insulation material group III, pollution degree 2, altitude < 5,000 m and overvoltage category II. Please take enough creepage distance between each pin.

Soldering Process

Wave Soldering	Preheating temperature	100 – 140°C
	Preheating time	within 40 seconds
	Heating temperature	260°C
	Heating time	within 10 seconds

Packaging

Type	Packaging Type	Pieces Per Box
FG	Tray	300

The product is packed in antistatic trays.

Marking



Lot Code	
1st and 2nd digit = Last two digits of Year	19 = 2019 20 = 2020 21 = 2021 22 = 2022
3rd and 4th digit = Month of the Year	01 = January 02 = February to 11 = November 12 = December
5th and 6th digit = Day of the Month	01 = 1st to 31 = 31st
7th digit = Serial Number	01, 02, etc.

Self-Test Operation

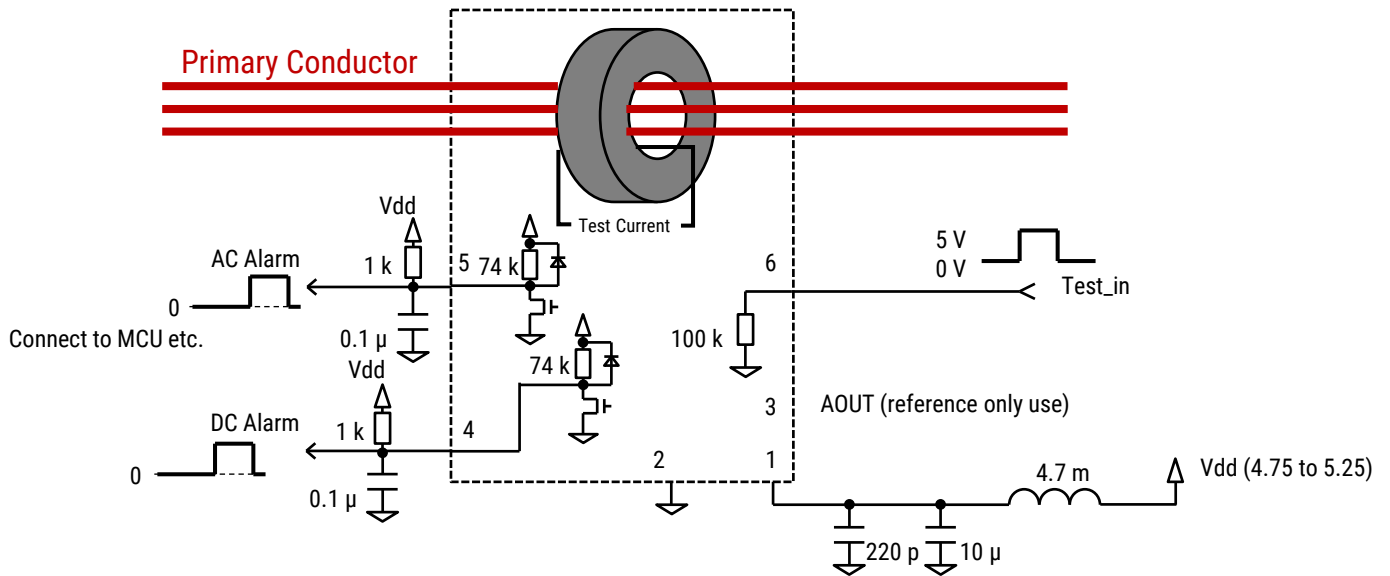

Time Chart

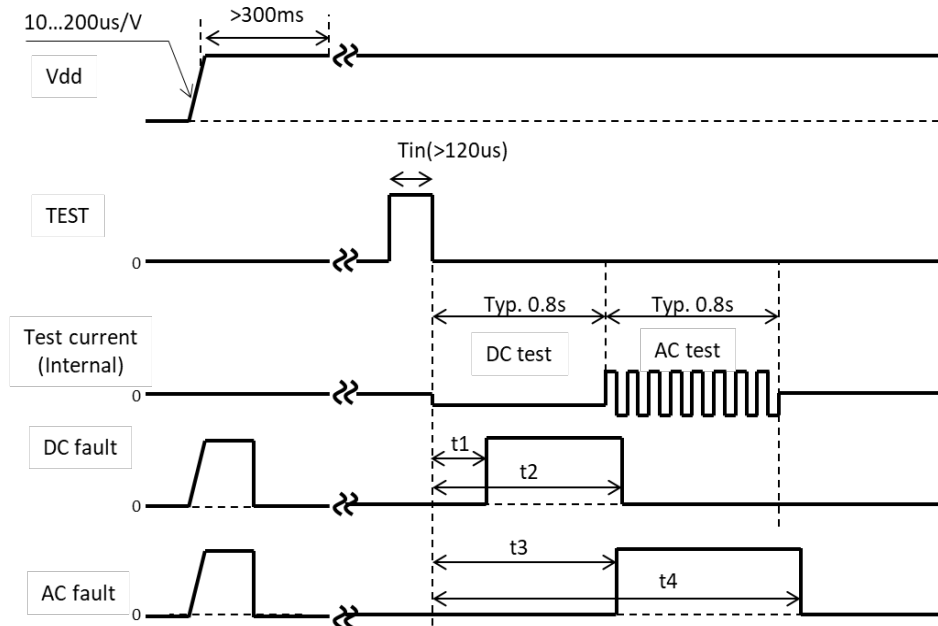

Parameter	Minimum	Maximum
t1	0.12	0.60
t2	0.80	1.30
t3	0.70	1.20
t4	1.40	2.10

Recommended Circuit

Typical Configuration Diagram

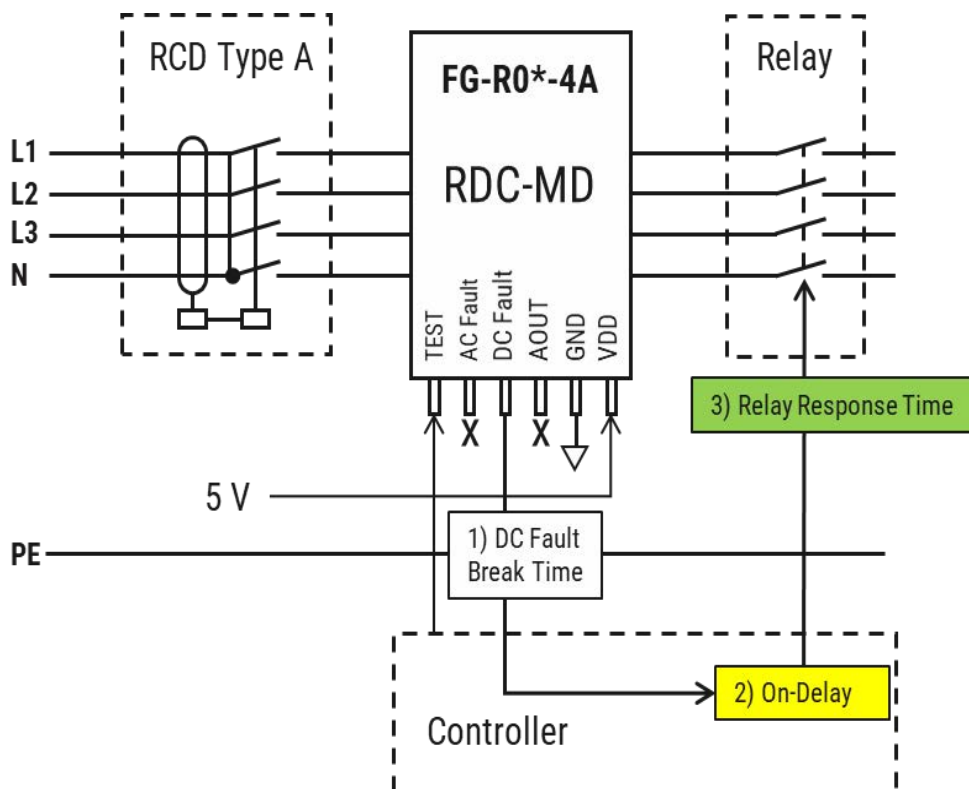

Appendix 3 Regarding Applying RDC-MD for 4A Type

FG-R0*-4A is tripped DC fault with high AC residual current of more than 60 mA.

When using the sensor as RDC-MD, break times are faster than required non-operating time.

You need to set a delay time to keep above minimum and below maximum response time at non-operating time.

An example of setting the delay time for the controller is shown above.

Recommended Circuit (cont.)

Calculation Example Based on Typical Values

- **On-delay needed: 69 ms**
- **Relay break time (typical): 15 ±4 ms (11 ~ 19 ms)**

Residual Currents	IEC62955 Requirement		FG-R05-4A	2) Add Delay (ms)	3) Add Relay Response Time (ms)
	Break Times (ms)	Response Non Operating Time (ms)	1) DC Fault Break Time (ms)		
DC 6 mA	≤10,000	N/A	≤1,000	≤1,069	<1,088
DC 60 mA	≤300	N/A	≤100	+69 → ≤169	+19 → <188
DC 200 mA	≤100	N/A	≤12	≤81	≤100
≤AC 30 mA	N/A	No DC Tripping	No DC Tripping	No DC Tripping	No DC Tripping
AC 60 mA	N/A	≥300	No DC Tripping	No DC Tripping	No DC Tripping
AC 150 mA	N/A	>80	>6	+69 → ≥75	+11 → ≥86
AC 5 A	N/A	>80	>0	≥69	≥80

Handling Precautions

Precautions for Product Storage

Current sensors should be stored in normal working environments. While the sensors are quite robust in other environments, exposure to high temperatures, high humidity, corrosive atmospheres, and long-term storage degrade solderability.

KEMET recommends that maximum storage temperature not exceed 85°C and atmospheres should be free of chlorine and sulfur-bearing compounds. Temperature fluctuations should be minimized to avoid condensation on the parts. Avoid storage near strong magnetic fields, as they can magnetize the product and cause its characteristics to change. Limit ambient magnetic fields to 50e or less.

For optimized solderability, the stock of current sensors should be used within 12 months of receipt.

Before Using Fluxgate-Based Residual Current Sensors

- Do NOT drop or apply any other mechanical stress, as such stresses may change performance characteristics.
- Do NOT exceed 260°C for 10 seconds when soldering. This is the maximum heat resistance grade of these sensors. Use a low-corrosion type flux when soldering.
- Do NOT allow strong static electricity near the sensor, as the circuit uses ICs. Static electricity can cause damage. Take static electricity precautions when handling.
- The case is Insulation Materials Group III. When designing the primary wire, be careful of clearance and creepage distance from the input/output terminal.