

FFH-23469-104

SHT 1.1

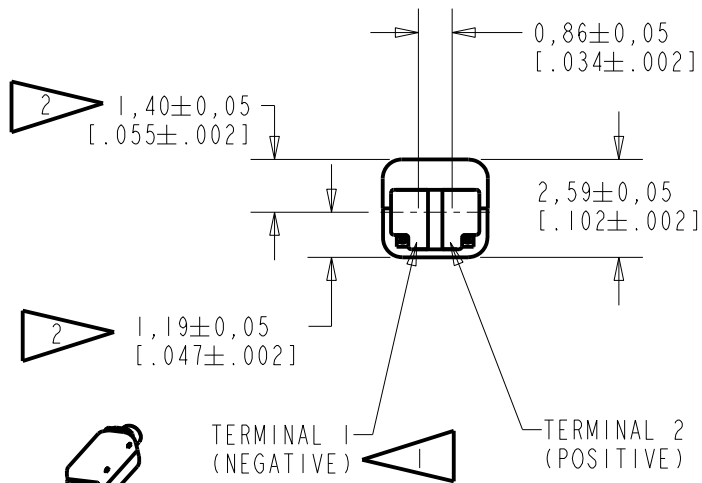
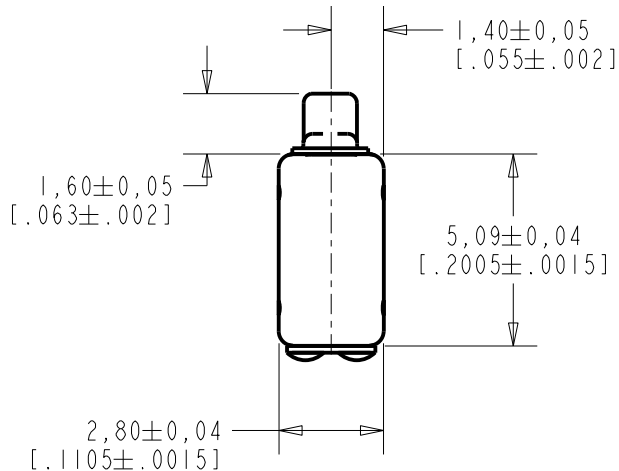

SCALE 2:1

NOMINAL WEIGHT
.18 GRAMS

DIMENSIONS IN MILLIMETERS [INCHES]

NOTES:

- 1 A POSITIVE GOING VOLTAGE AT TERMINAL 2, RELATIVE TO TERMINAL 1, CAUSES A DECREASE IN PRESSURE AT THE SOUND OUTLET.
- 2 LOCATED FROM TWO SURFACES FOR CUSTOMER CONVENIENCE. ONLY APPLICABLE FROM ONE SURFACE, NOT TO BE USED TOGETHER.

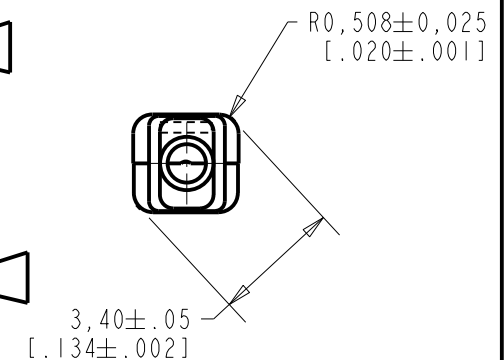
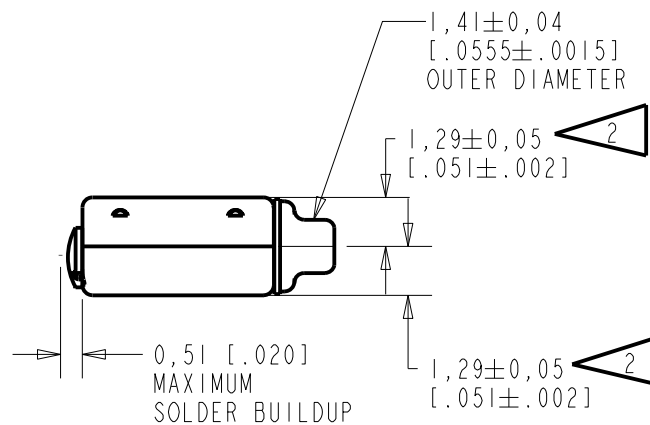

Revision	C.O. #	Implementation Date	RELEASE LEVEL	REVISION
B	C10109708P	10-28-10	Active	B
A	C10103482	12-7-05		

SCALE: 5:1		DR. BY	DATE
DO NOT SCALE DRAWING		CRG	12-7-05
TITLE: RECEIVER		CK. BY	DATE
OUTLINE DRAWING		GJP	12-8-05
FFH-23469-104		APP. BY	DATE
SHT 1.1		GJP	12-8-05

KNOWLES ELECTRONICS
ITASCA, ILLINOIS U.S.A.

THE FFH-23469-104 IS A FERROFLUID AND TYPE III DAMPED FH-23469 RECEIVER WITH A PEAK OF 4dB RELATIVE TO THE SENSITIVITY AT 1kHz UNDER CONSTANT VOLTAGE DRIVE CONDITIONS.

CONSTANT VOLTAGE DRIVE CONDITIONS

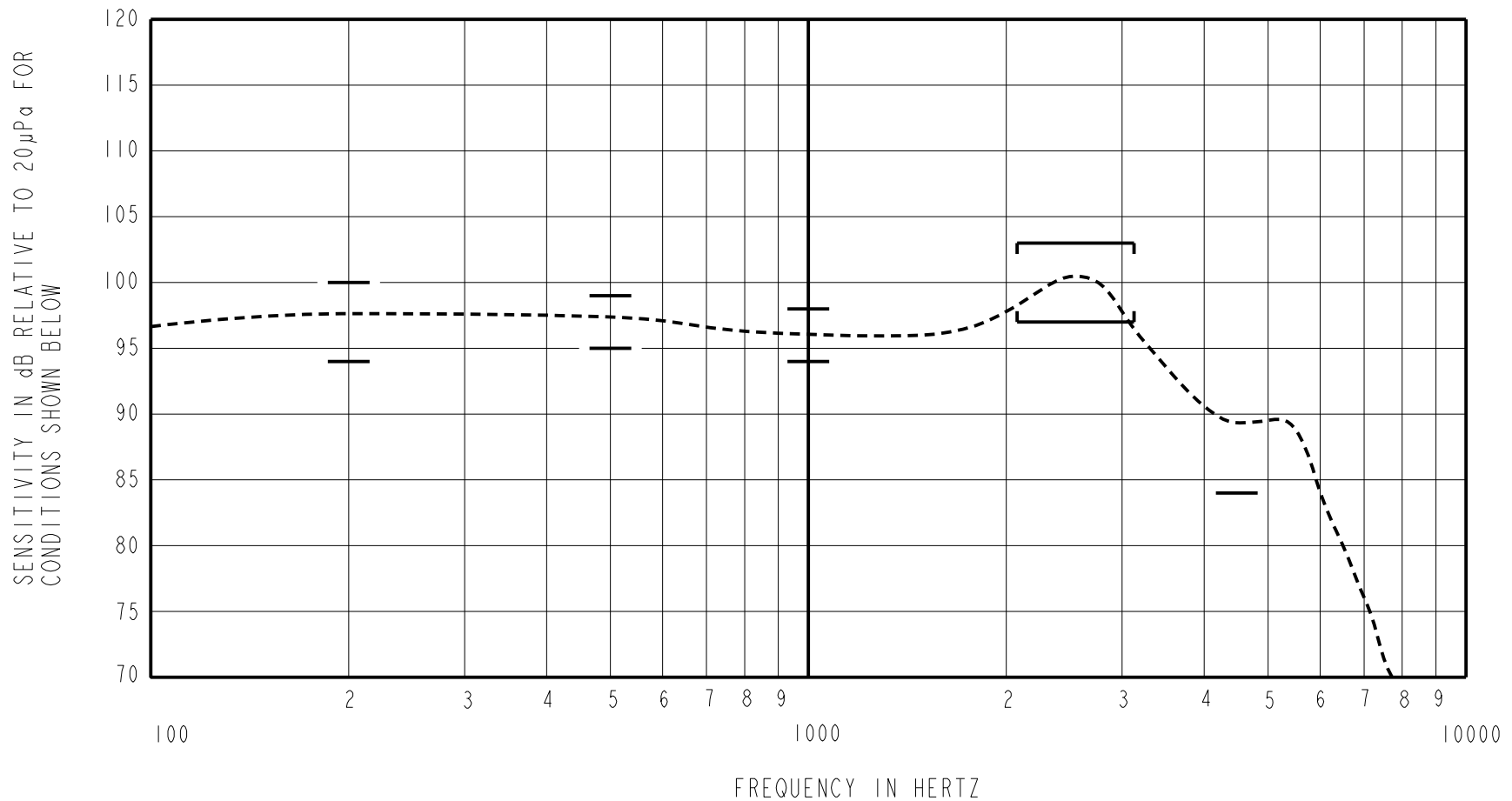

ACOUSTICAL

SENSITIVITY
DEVICE WILL PRODUCE THE SPL LISTED BELOW UNDER TEST CONDITIONS DESCRIBED IN TABLE 3.
NOMINAL SENSITIVITY AT 1kHz IS dB RELATIVE TO 20µPa. ALL OTHER VALUES
IN dB RELATIVE TO THE SENSITIVITY AT 1kHz.

FREQUENCY (Hz)	MINIMUM	NOMINAL	MAXIMUM
200	-2.0	1.0	+4.0
500	-1.0	+1.0	3.0
1000	-2.0	96.0	2.0
2100-3100	+1.0	+4.0	+7.0
4500	-12.0	---	---

PORT LOCATION: 12S

TABLE 1

TOTAL HARMONIC DISTORTION
DEVICE WILL NOT EXCEED TOTAL HARMONIC DISTORTION LEVELS LISTED BELOW.

FREQUENCY (Hz)	AC DRIVE (V rms)	DC BIAS (V)	LIMIT (%)
500	0.733	0	10
870	0.260	0	6
1300	0.260	0	6

TABLE 2

TEST CONDITIONS

NOMINAL SOURCE VOLTAGE	0.260 V rms, 0 mA DC BIAS
SOURCE IMPEDANCE	<1 Ohm
TUBING	10mm [.394"] LONG, 1mm [.039"] I.D.
COUPLER CAVITY	2 CM ³ , SIMULATED ANSI S3.7 TYPE HA-3 (IEC 126)

TABLE 3

ELECTRICAL

DC RESISTANCE	240 OHMS ± 10%
IMPEDANCE @ 500 Hz	360 OHMS ± 15%
IMPEDANCE @ 1kHz	564 OHMS ± 15%

TABLE 4

ISOLATION: CASE WILL BE ELECTRICALLY ISOLATED FROM THE COIL CIRCUIT.

TEMPERATURE: OPERATING RANGE FROM 0°C TO 63°C (SENSITIVITY WILL NOT VARY BY MORE THAN ±3 dB WITHIN RANGE)
SENSITIVITY AT 0°C IS 2dB LOWER THAN THE SENSITIVITY AT ROOM TEMPERATURE.
DELTA PEAK IS 1.5dB HIGHER AT BODY TEMPERATURE (37°C))
STORAGE RANGE FROM -40°C TO 63°C

Revision	C.O. #	Implementation Date	RELEASE LEVEL	REVISION
B	C10109708P	10-28-10	Active	B
A	C10103482	12-7-05		

KNOWLES ELECTRONICS
ITASCA, ILLINOIS U.S.A.

WHEN TEST LIMITS ARE USED TO ESTABLISH INCOMING INSPECTION ACCEPTANCE/REJECTION CRITERIA, CORRELATION OF TEST EQUIPMENT WITH KNOWLES IS ALSO REQUIRED FOR ELIMINATION OF EQUIPMENT AND TEST METHOD VARIATION

TITLE: **RECEIVER**
PERFORMANCE SPECIFICATION

FFH-23469-104
SHT 2.1

DR. BY	DATE
CRG	12-7-05
CK. BY	DATE
GJP	12-8-05
APP. BY	DATE
GJP	12-8-05