

FL7760LED1GEVK

3W SPI Controllable LED Driver Evaluation Board User's Manual

OVERVIEW

This manual covers the specification, theory of operation, testing and construction of the FL7760LED1GEVK demonstration kit. The FL7760 kit demonstrates a 1 A buck LED driver intended for a single high-power LED. The SPI (Serial Peripheral Interface) bus does both analog and PWM dimming. The kit includes a load/SPI interface board to facilitate operation of the driver. The driver can be driven independently from any SPI controller. The nominal input voltage is 12 V.

Table 1. SPECIFICATIONS

Input Voltage	10.8 V dc – 13.2 V dc	
Output Voltage	2.5 V dc – 5.0 V dc	
Output Current	1 A	Max
Output Ripple	40 mA	P–P
Efficiency	85%	Typ.
Switching Frequency	200 kHz	
Rise/Fall Time	< 20 μ s	
Dimming Interface	SPI	
Dimming Resolution	8 bits	
PCB Size	30 mm \times 30 mm	

The key features of this demo kit include:

- Low Parts Count
- Single Sided Assembly
- Small Footprint
- Very Fast Rise/Fall Times
- SPI Dimming Control for Analog and PWM Dimming
- 12 V Operation
- Integrated Thermal Shutdown and UVLO

THEORY OF OPERATION

Power Stage

The power stage is a CCM inverted buck converter. The output inductor sets the switching frequency because the control operates in hysteretic control mode. The peak and valley current are fixed percentages of the current reference. This fixes the inductor ripple current and eliminates the need for closed loop compensation. A novel high side current sense enables direct accurate control of the output current.



ON Semiconductor®

www.onsemi.com

EVAL BOARD USER'S MANUAL

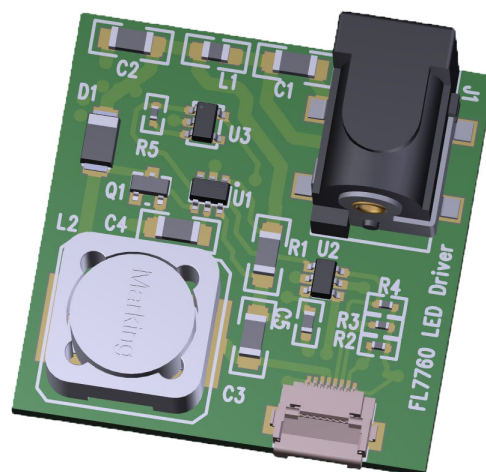

**FL7760LED1GEVK
Evaluation Board**

FL7760LED1GEVK

HV Start

The FL7760 supplies its own Vcc power greatly simplifying implementation. The input voltage range is 8 V – 70V. The internal Vcc regulates to 5 V ± 10%. The internal Vcc supplies a 3.3 V LDO for powering the DAC. The regulator and DAC draw less than 1mA combined.

Dimming

The FL7760 dim input controls both amplitude and on/off control. This makes the dim interface controllable by analog, PWM, or both at the same time. The DAC has an output range of 0 V – 3.3 V for 8 bits of resolution. A dim signal below 0.5 V turns off the output and a dim signal above 3 V is 100% output.

Protection

Thermal Protection

The thermal protection is built into the FL7760 and shuts down the FL7760 when the die temperature exceeds 150°C.

OVP

The output voltage is inherently limited to be less than or equal to Vin. As such, no OVP is required due this inherent limitation.

Load Board Operation

The load board connects to the LED driver via an 8 conductor FPC cable. The FPC cable makes a simple and convenient interconnection. The load board serves 2 major functions: 1) provide an easy connection to an LED load 2) provide a USB-SPI bridge for computer control of the LED driver.

The daughter card on the load has a mini USB-A connection for attachment to your computer. See the test procedure for details of the setup of the SPI terminal application.

SCHEMATIC

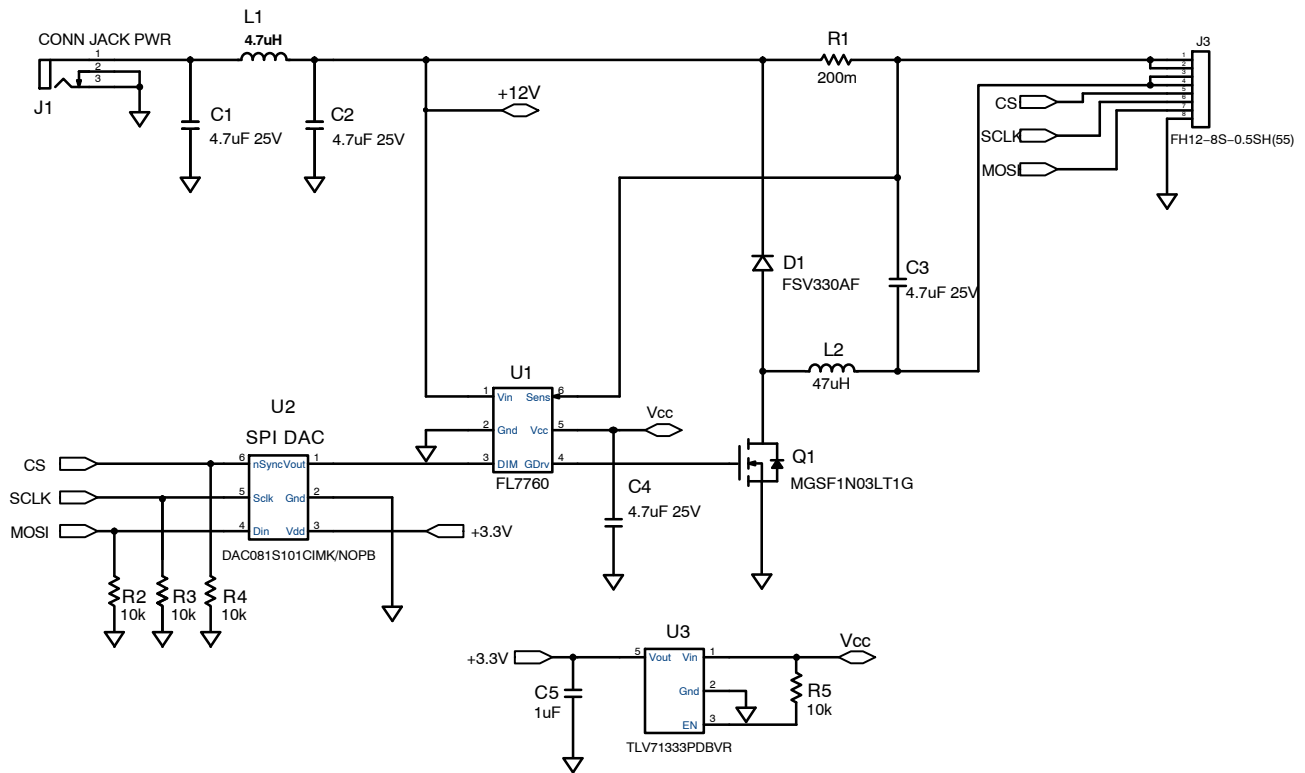

Figure 1. LED Driver Circuit

FL7760LED1GEVK

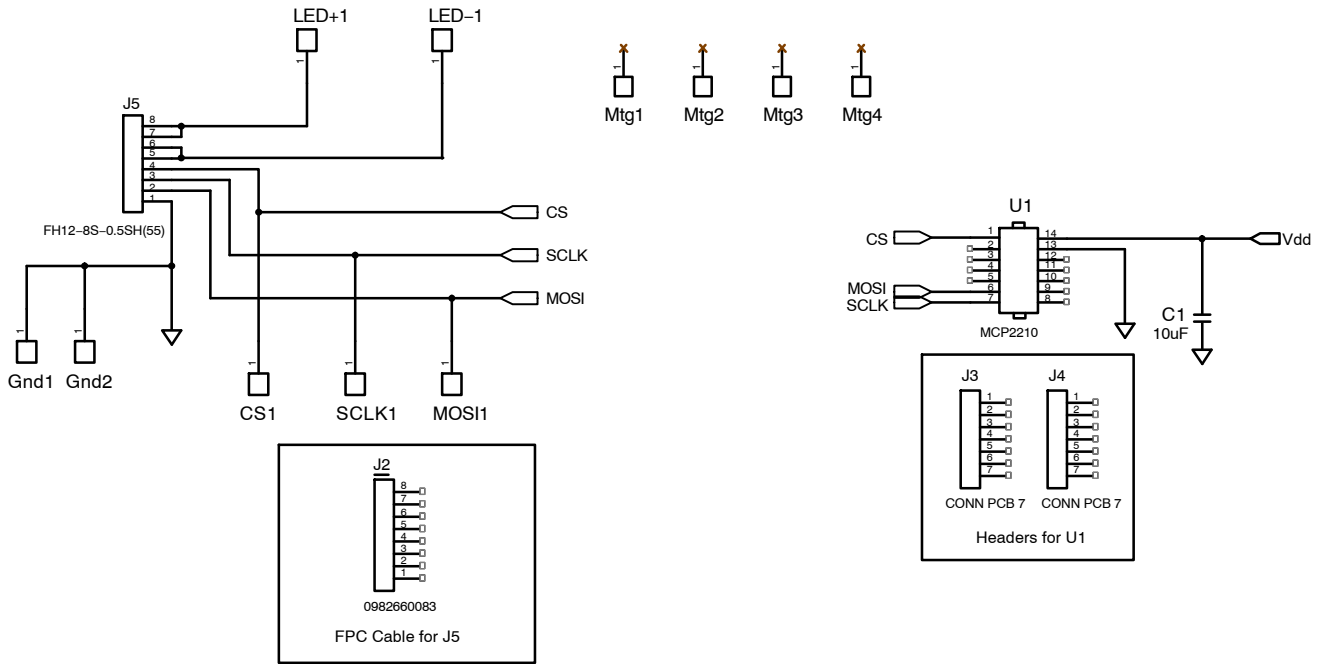

Figure 2. LED Driver Circuit

Table 2. BILL OF MATERIAL

Qty	Reference	Part	Distributor	Dist. P/N	Manufacturer	Mfr_PN
4	C1, C2, C3, C4	4.7 uF 25 V	Digikey	1276-3178-1-ND	Samsung	CL31B475KAHNNWE
1	C5	1 uF	Digikey	587-3247-1-ND	Taiyo Yuden	UMK107AB7105KA-T
1	D1	FSV330AF	ON Semiconductor	FSV330AFCT-ND	ON Semiconductor	FSV330AF
1	J1	CONN JACK PWR	Digikey	732-5929-1-ND	Würth	694106106102
1	J3	FH12-8S-0.5SH(55)	Digikey	H124618CT-ND	Hirose	FH12-8S-0.5SH(55)
1	L1	4.7 uH	Digikey	445-6760-1-ND	TDK	MLZ2012N4R7LT000
1	L2	4.7 uH	Digikey	732-2197-1-ND	Würth	7447715470
1	Q1	MGSF1N03LT1G	ON Semiconductor	MGSF1N03LT1GOSCT-ND	ON Semiconductor	MGSF1N03LT1G
1	R1	200 m	Digikey	CSR1206FKR200CT-ND	Stackpole	CSR1206FKR200
4	R2, R3, R4, R5	10 k	Digikey	311-10.0KLRCT-ND	Yageo	RC0402FR-0710KL
1	U1	FL7760	ON Semiconductor	FL7760	ON Semiconductor	FL7760
1	U2	DAC081S101CIMK/NOPB	Digikey	DAC081S101CIMK/NOPBCT-ND	TI	DAC081S101CIMK/NOPB
1	U3	TLV71333PDBVR	Digikey	296-35591-1-ND	TI	TLV71333PDBVR
5	SCLK1, MOSI1, Gnd1, CS1, Gnd2	Test Point	Digikey	952-2264-1-ND	Harwin	S2751-46R
1	C1	10 uF	Digikey	1276-6641-1-ND	Samsung	CL31B106MOHNNNE
1	J2	982660083	Digikey	WM14102-ND	Molex	982660083
2	J3, J4	CONN PCB 7	Digikey	S7040-ND	Sullins	PPPC071LFBN-RC
1	J5	FH12-8S-0.5SH(55)	Digikey	H124618CT-ND	Hirose	FH12-8S-0.5SH(55)
2	LED-1, LED+1	MTG_Hole	Digikey	3267	Pomona	3267
1	U1	MCP2210	Digikey	ADM00419-ND	Microchip	ADM00419

FL7760LED1GEVK

TEST PROCEDURE

Equipment Needed

- DC Source – 12 V ± 5% @ 1 A
- 2 – DC Voltmeter – 300 V dc minimum 0.1% accuracy or better
- 2 – DC Ammeter – 1 A dc minimum 0.1% accuracy or better
- LED Load – 2.5 V – 5.0 V @ 1.0 A

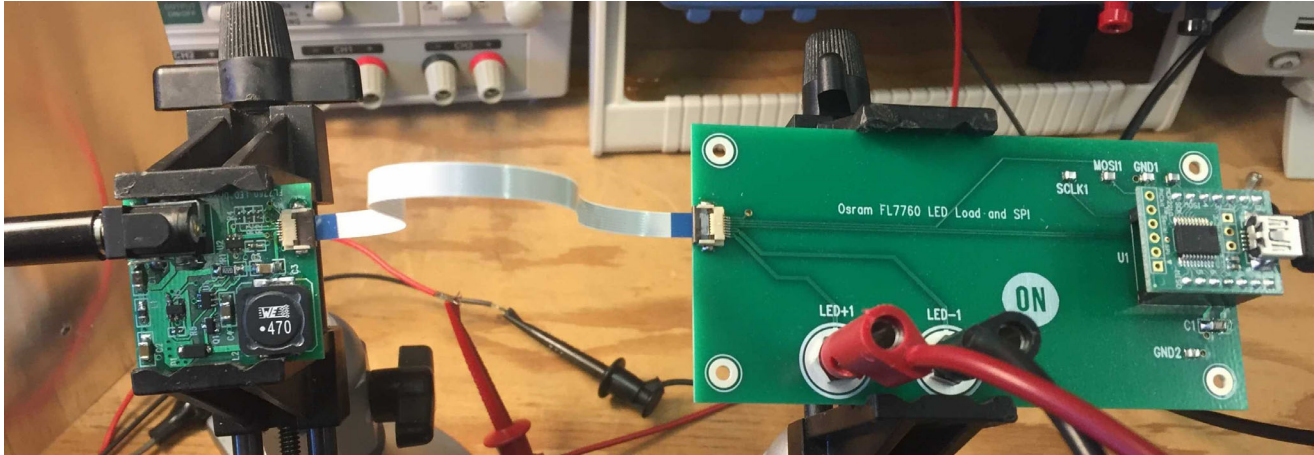

Figure 3. Test Set Up

The Connections

1. Connect the LED load board to the LED driver using the FPC cable provided in the kit.
2. Connect red (+) and black (-) leads through the ammeter to the LED load.
3. Connect a 12 V dc source to the input power connector.

NOTE: Unless otherwise specified, all voltage measurements are taken at the terminals of the UUT.

Functional Test Procedure

1. Set the LED Load for 3.5 V output.
2. Set the input voltage to 12 V.
3. Measure input voltage and current.
4. Measure output voltage and current.

Regulation

See Table 3.

Table 3. REGULATION

DAC Data	Iout Target	Output Current	Output Voltage	Input Voltage	Input Current
00 00	0 A				
0F F0	1 A ± 5%				
07 00	0.5 A ± 5%				

$$\text{Efficiency} = \frac{V_{\text{out}} \times I_{\text{out}}}{V_{\text{in}} \times I_{\text{in}}} \times 100\%$$

FL7760LED1GEVK

TEST DATA

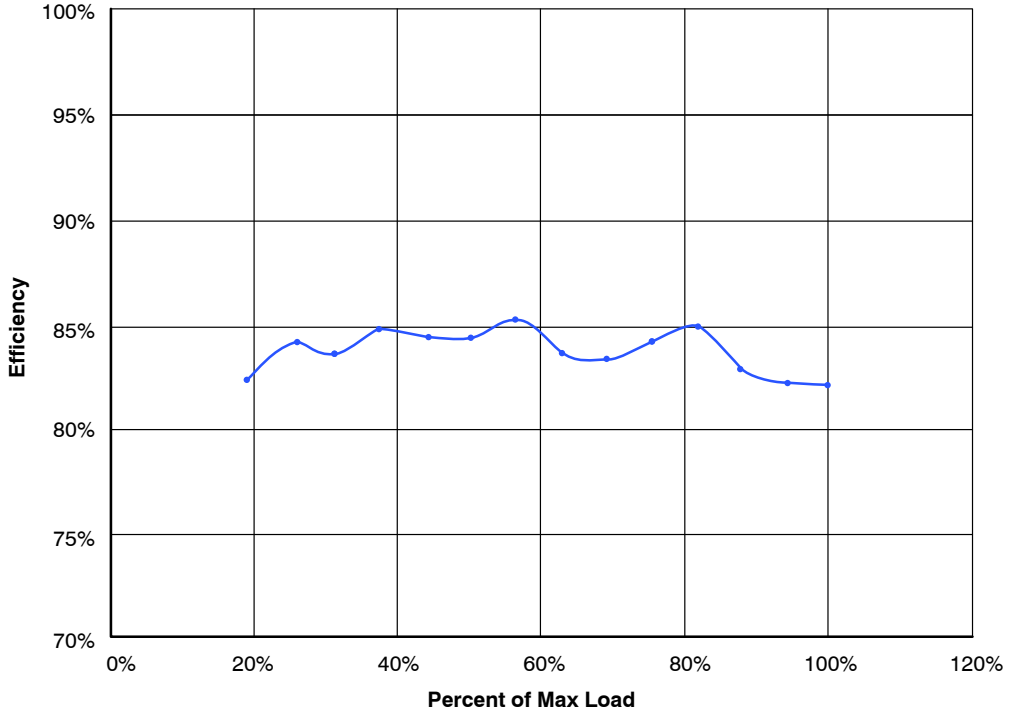

Figure 4. Efficiency

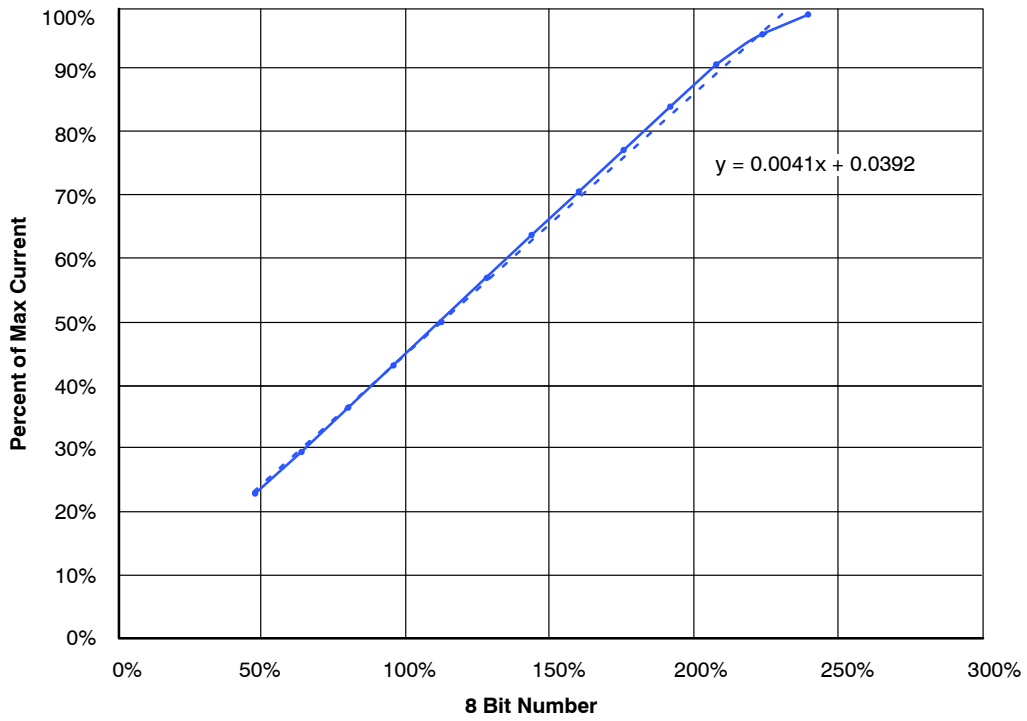

Figure 5. Dim Curve

FL7760LED1GEVK

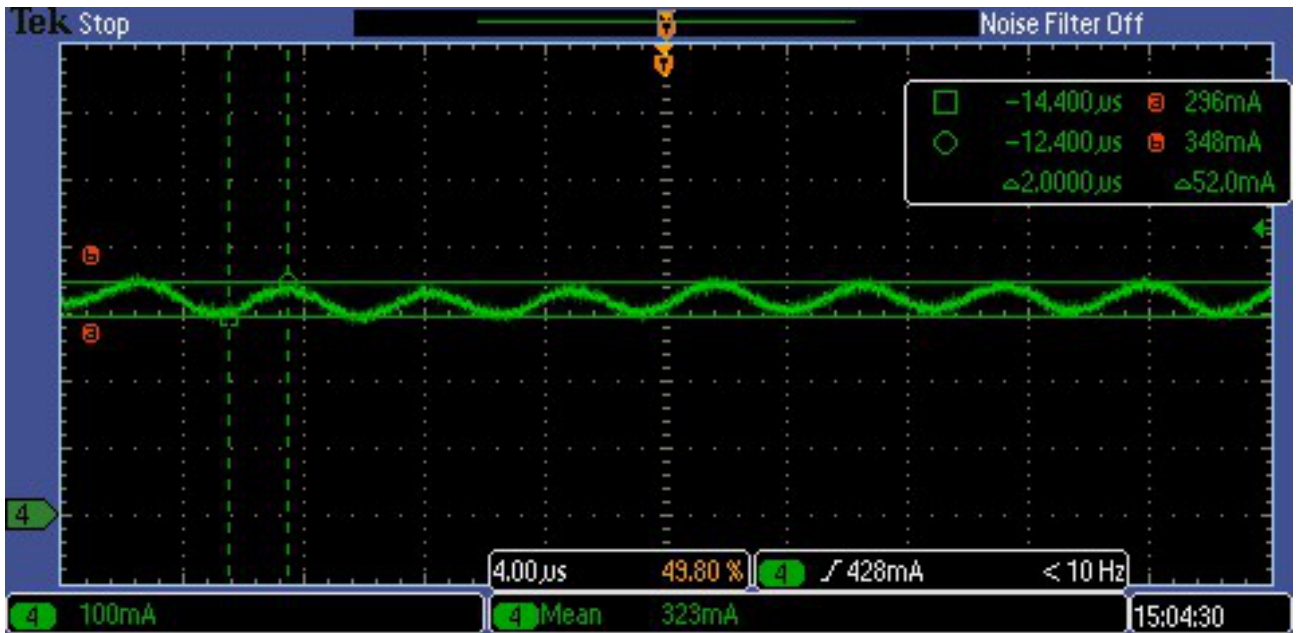

Figure 6. Input Current Ripple

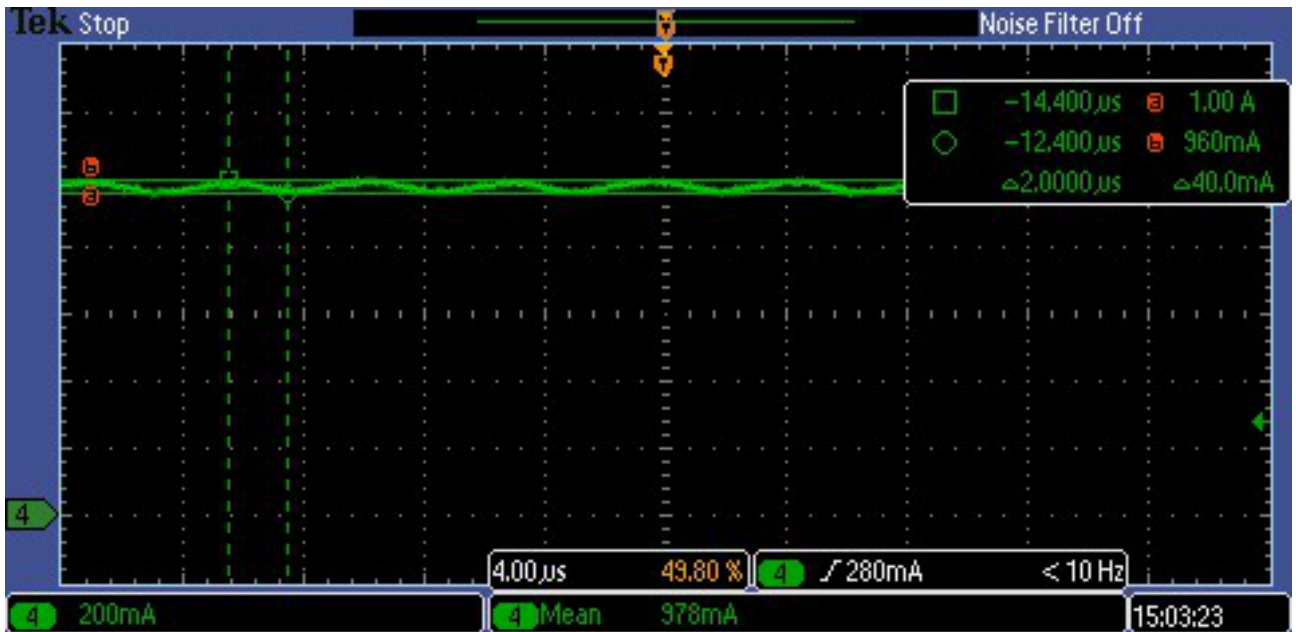

Figure 7. Output Current Ripple

FL7760LED1GEVK

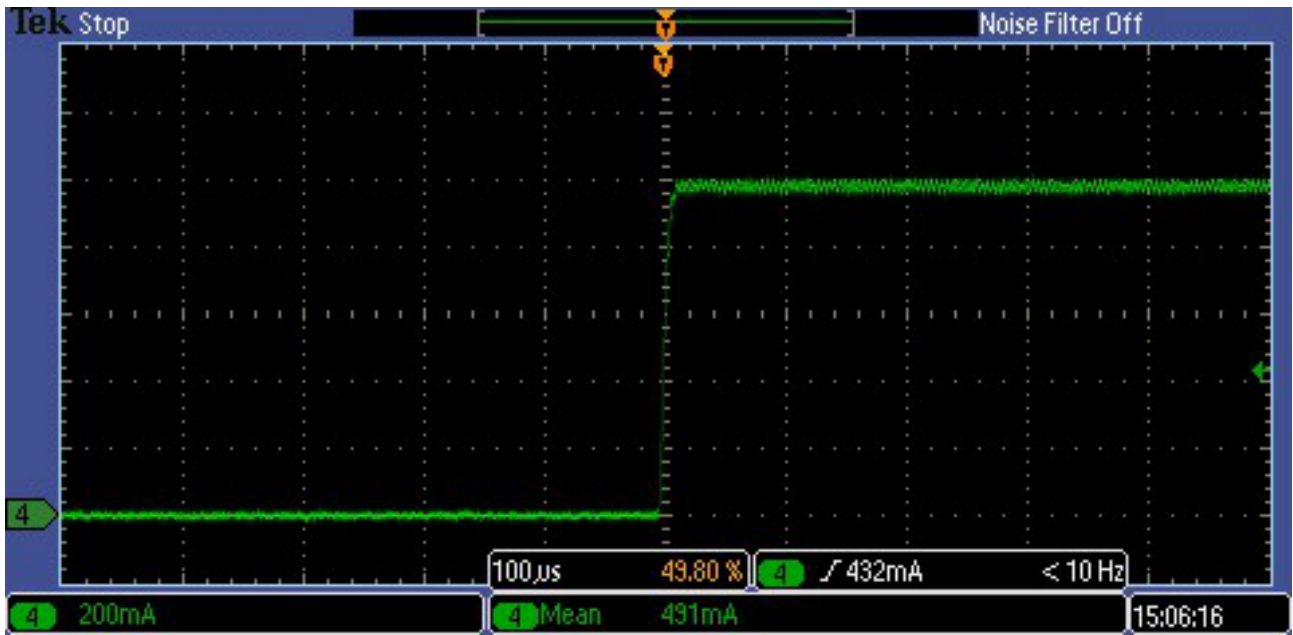

Figure 8. Input Current Rise

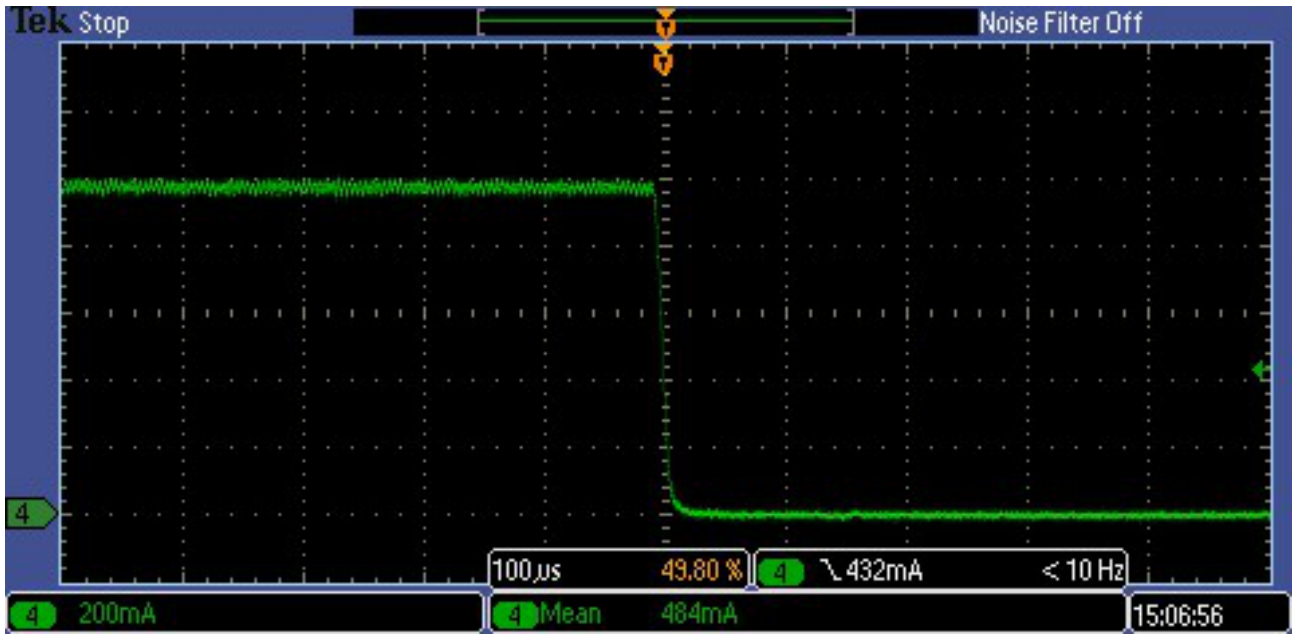

Figure 9. Output Current Fall

FL7760LED1GEVK

THERMAL IMAGE

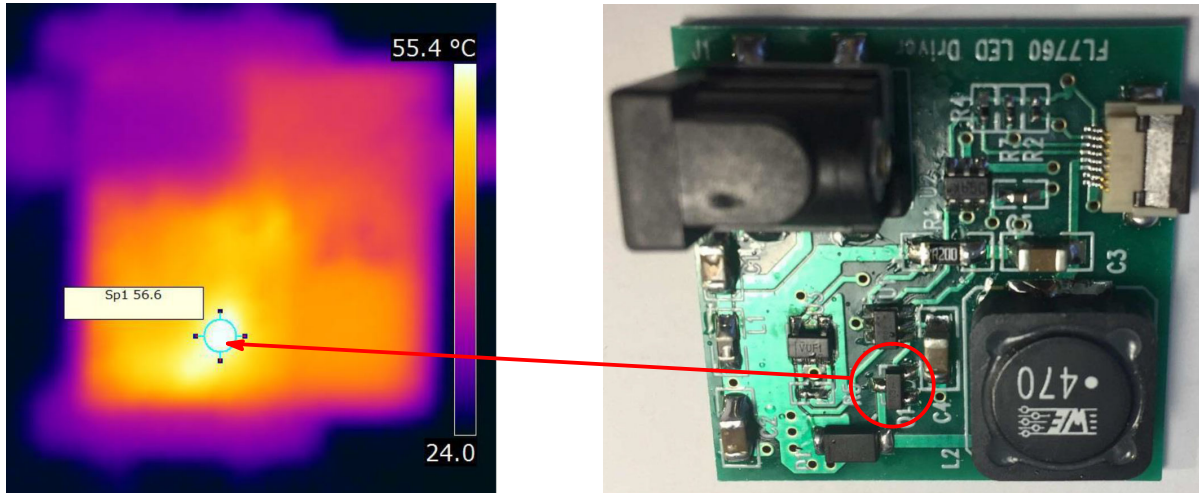

Figure 10.