

# Half-Bridge LLC Resonant Control IC for Lighting

## FLS-XS Series

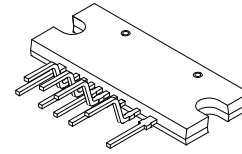

SIP9 26x10.5  
CASE 127EM

### Description

The FLS-XS series of general lighting power controllers includes highly integrated power switches for medium- to high-power lumens applications. Offering everything necessary to build a reliable and robust half-bridge resonant converter, the FLS-XS series simplifies designs and improves productivity, while improving performance. The FLS-XS series combines power MOSFETs with fast-recovery type body diodes, a high-side gate-drive circuit, an accurate current controlled oscillator, frequency limit circuit, soft-start, and built-in protection functions. The high-side gate-drive circuit has common-mode noise cancellation capability, which guarantees stable operation with excellent noise immunity. The fast-recovery body diode of the MOSFETs improves reliability against abnormal operation conditions, while minimizing the effect of reverse recovery. Using zero voltage switching (ZVS) dramatically reduces the switching losses and significantly improves efficiency. ZVS also reduces switching noise noticeably, which allows a small-sized Electromagnetic Interference (EMI) filter.

The FLS-XS series can be applied to resonant converter topologies such as series resonant, parallel resonant, and LLC resonant converters.

### Features

- Variable Frequency Control with 50% Duty Cycle for Half-Bridge Resonant Converter Topology
- High Efficiency through Zero Voltage Switching (ZVS)
- Internal UniFET™ with Fast-Recovery Body Diode
- Fixed Dead Time (350 ns) Optimized for MOSFETs
- Up to 300 kHz Operating Frequency
- Auto-Restart Operation for All Protections with External LV<sub>CC</sub>
- Protection Functions: Over-Voltage Protection (OVP), Over-Current Protection (OCP), Abnormal Over-Current Protection (AOCP), Internal Thermal Shutdown (TSD)
- These are Pb-Free Devices

### Applications

- General LED Lighting Power
- Industrial, Commercial, and Residential LED Lighting Fixtures
- Outdoor Lighting: Street, Roadway, Parking, Construction and Ornamental LED Lighting Fixtures

### MARKING DIAGRAM

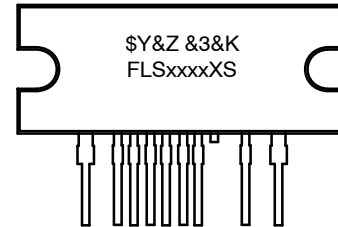

- \$Y = onsemi logo
- &Z = Assembly Plant Code
- &3 = 3-Digit Date Code
- &K = 2-Digits Lot Run Traceability Code
- FLSxxxxXS = Specific Device Code
- xxxx = 2100, 1800, 1700, 1600

### ORDERING INFORMATION

See detailed ordering and shipping information on page 2 of this data sheet.

# FLS-XS Series

## ORDERING INFORMATION

Part Number	Package	Operating Junction Temperature	$R_{DS(ON\_MAX)}$	Maximum Output Power without Heatsink ( $V_{IN} = 350\text{ V} \sim 400\text{ V}$ ) (Notes 1, 2)	Maximum Output Power with Heatsink ( $V_{IN} = 350\text{ V} \sim 400\text{ V}$ ) (Notes 1, 2)	Shipping
FLS2100XS	9-SIP (Pb-Free)	-40°C to 130°C	0.51 $\Omega$	180 W	400 W	475 Units / Tube
FLS1800XS			0.95 $\Omega$	120 W	260 W	
FLS1700XS			1.25 $\Omega$	100 W	200 W	
FLS1600XS			1.55 $\Omega$	80 W	160 W	

1. The junction temperature can limit the maximum output power.
2. Maximum practical continuous power in an open-frame design at 50°C ambient.

## Application Circuit Diagram

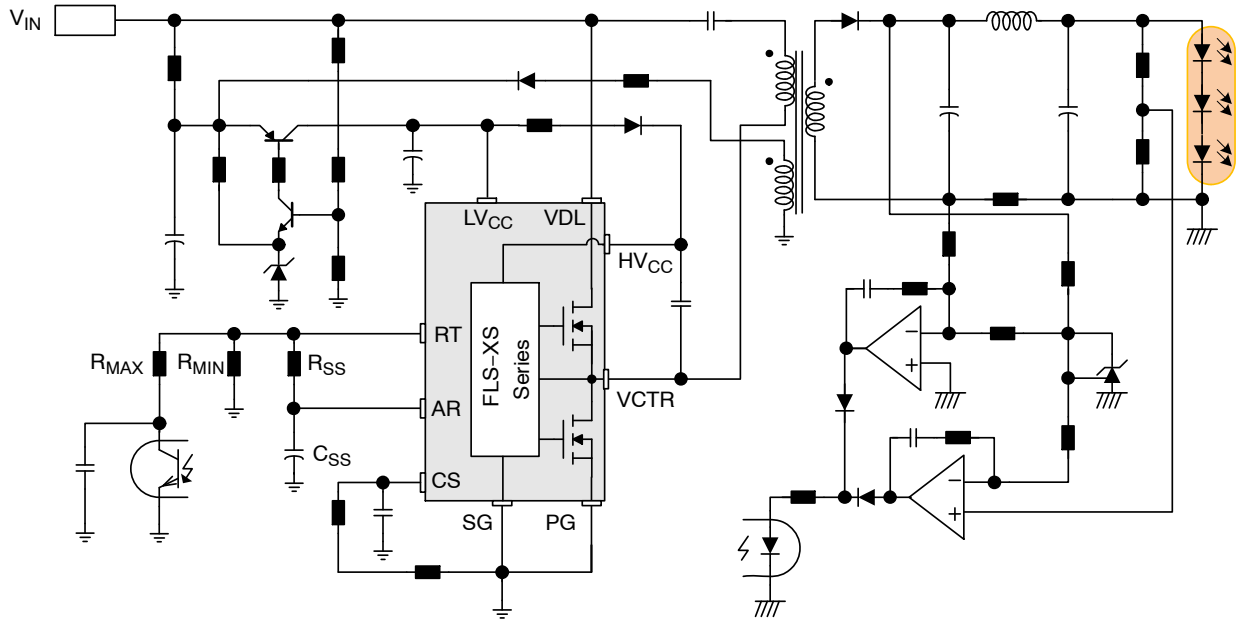

Figure 1. Typical Application Circuit for LLC Resonant Half-Bridge Converter

# FLS-XS Series

## Block Diagram

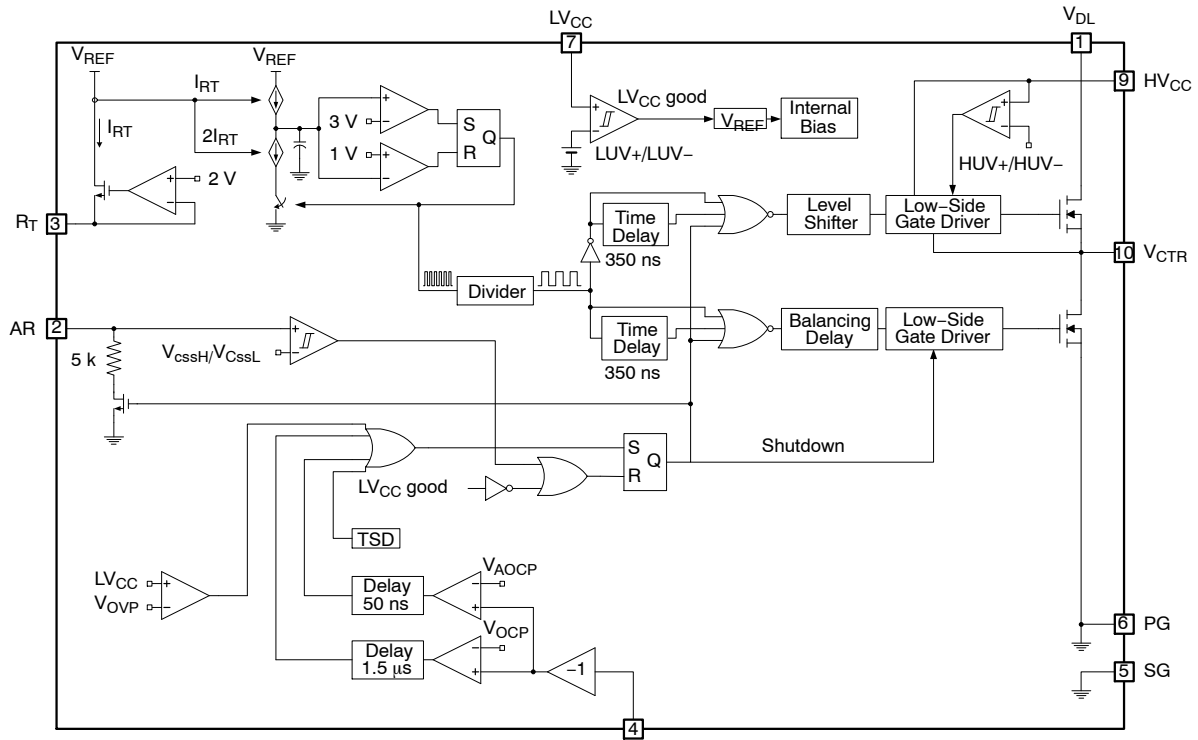
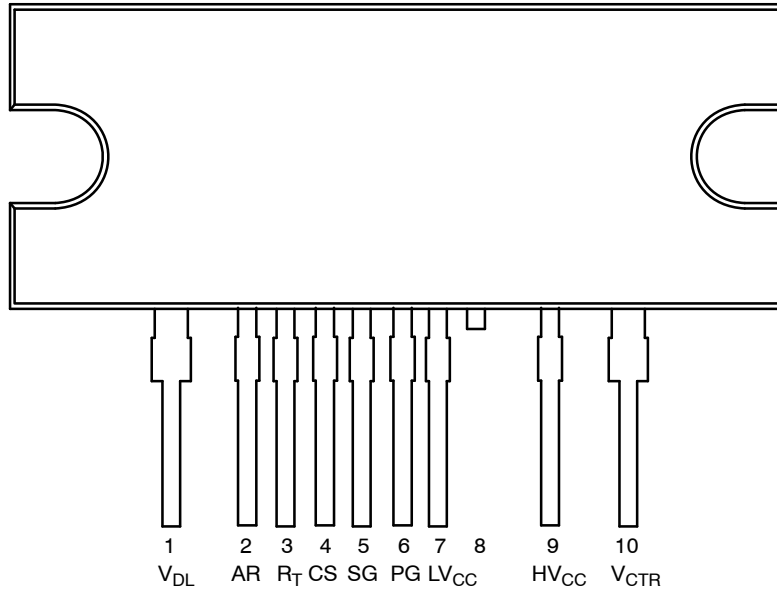

Figure 2. Functional Block Diagram

# FLS-XS Series

## Pin Configuration



**Figure 3. Pin Configuration**

## PIN DEFINITIONS

Pin #	Name	Description
1	$V_{DL}$	This is the drain of the high-side MOSFET, typically connected to the input DC link voltage.
2	AR	This pin is for discharging the external soft-start capacitor when any protections are triggered. When the voltage of this pin drops to 0.2 V, all protections are reset and the controller starts to operate again.
3	$R_T$	This pin programs the switching frequency. Typically, an opto-coupler is connected to control the switching frequency for the output voltage regulation.
4	CS	This pin senses the current flowing through the low-side MOSFET. Typically, negative voltage is applied on this pin.
5	SG	This pin is the control ground.
6	PG	This pin is the power ground. This pin is connected to the source of the low-side MOSFET.
7	$LV_{CC}$	This pin is the supply voltage of the control IC.
8	NC	No connection
9	$HV_{CC}$	This is the supply voltage of the high-side gate-drive circuit IC.
10	$V_{CTR}$	This is the drain of the low-side MOSFET. Typically, a transformer is connected to this pin.

## FLS-XS Series

### ABSOLUTE MAXIMUM RATINGS (T<sub>A</sub> = 25°C unless otherwise specified)

Symbol	Parameter	Min	Max	Unit	
V <sub>DS</sub>	Maximum Drain-to-Source Voltage (VDL-VCTR and VCTR-PG)	500		V	
LV <sub>CC</sub>	Low-Side Supply Voltage	-0.3	25.0	V	
HV <sub>CC</sub> to V <sub>CTR</sub>	High-Side V <sub>CC</sub> Pin to Low-Side Drain Voltage	-0.3	25.0	V	
HV <sub>CC</sub>	High-Side Floating Supply Voltage	-0.3	525.0	V	
V <sub>AR</sub>	Auto-Restart Pin Input Voltage	-0.3	LV <sub>CC</sub>	V	
V <sub>CS</sub>	Current-Sense (CS) Pin Input Voltage	-5.0	1.0	V	
V <sub>RT</sub>	R <sub>T</sub> Pin Input Voltage	-0.3	5.0	V	
dV <sub>CTR</sub> /dt	Allowable Low-Side MOSFET Drain Voltage Slew Rate		50	V/ns	
P <sub>D</sub>	Total Power Dissipation (Note 3)	FLS2100XS	12.0	W	
		FLS1800XS	11.7		
		FLS1700XS	11.6		
		FLS1600XS	11.5		
T <sub>J</sub>	Maximum Junction Temperature (Note 4)		+150	°C	
	Recommended Operating Junction Temperature (Note 4)	-40	+130		
T <sub>STG</sub>	Storage Temperature Range	-55	+150	°C	
<b>MOSFET Section</b>					
V <sub>DRG</sub>	Drain Gate Voltage (R <sub>GS</sub> = 1 MΩ)	500		V	
V <sub>GS</sub>	Gate Source (GND) Voltage		±30	V	
I <sub>DM</sub>	Drain Current Pulsed (Note 5)	FLS2100XS	32	A	
		FLS1800XS	23		
		FLS1700XS	20		
		FLS1600XS	18		
I <sub>D</sub>	Continuous Drain Current	FLS2100XS	T <sub>C</sub> = 25°C	10.5	A
			T <sub>C</sub> = 100°C	6.5	
		FLS1800XS	T <sub>C</sub> = 25°C	7.0	
			T <sub>C</sub> = 100°C	4.5	
		FLS1700XS	T <sub>C</sub> = 25°C	6.0	
			T <sub>C</sub> = 100°C	3.9	
		FLS1600XS	T <sub>C</sub> = 25°C	4.5	
			T <sub>C</sub> = 100°C	2.7	
<b>Package Section</b>					
Torque	Recommended Screw Torque		5 ~ 7	kgf.cm	

Stresses exceeding those listed in the Maximum Ratings table may damage the device. If any of these limits are exceeded, device functionality should not be assumed, damage may occur and reliability may be affected.

3. Per MOSFET when both MOSFETs are conducting.
4. The maximum value of the recommended operating junction temperature is limited by thermal shutdown.
5. Pulse width is limited by maximum junction temperature.

### THERMAL CHARACTERISTICS (T<sub>A</sub> = 25°C unless otherwise specified)

Symbol	Parameter	Value	Unit
θ <sub>JC</sub>	Junction-to-Case Center Thermal Impedance (Both MOSFETs Conducting)	FLS2100XS	10.44
		FLS1800XS	10.68
		FLS1700XS	10.79
		FLS1600XS	10.89

## FLS-XS Series

### ELECTRICAL CHARACTERISTICS ( $T_A = 25^\circ\text{C}$ unless otherwise specified)

Symbol	Parameter	Condition	Min	Typ	Max	Unit
--------	-----------	-----------	-----	-----	-----	------

#### MOSFET Section

BV <sub>DSS</sub>	Drain-to-Source Breakdown Voltage	$I_D = 200 \mu\text{A}, T_A = 25^\circ\text{C}$		500			V
		$I_D = 200 \mu\text{A}, T_A = 125^\circ\text{C}$			540		
R <sub>DS(ON)</sub>	On-State Resistance	FLS2100XS	$V_{GS} = 10 \text{ V}, I_D = 6.0 \text{ A}$		0.41	0.51	Ω
		FLS1800XS	$V_{GS} = 10 \text{ V}, I_D = 3.0 \text{ A}$		0.77	0.95	
		FLS1700XS	$V_{GS} = 10 \text{ V}, I_D = 2.0 \text{ A}$		1.00	1.25	
		FLS1600XS	$V_{GS} = 10 \text{ V}, I_D = 2.25 \text{ A}$		1.25	1.55	
t <sub>rr</sub>	Body Diode Reverse Recovery Time (Note 6)	FLS2100XS	$V_{GS} = 0 \text{ V}, I_{\text{Diode}} = 10.5 \text{ A},$ $dI_{\text{Diode}}/dt = 100 \text{ A}/\mu\text{s}$		120		ns
		FLS1800XS	$V_{GS} = 0 \text{ V}, I_{\text{Diode}} = 7.0 \text{ A},$ $dI_{\text{Diode}}/dt = 100 \text{ A}/\mu\text{s}$		160		
		FLS1700XS	$V_{GS} = 0 \text{ V}, I_{\text{Diode}} = 6.0 \text{ A},$ $dI_{\text{Diode}}/dt = 100 \text{ A}/\mu\text{s}$		160		
		FLS1600XS	$V_{GS} = 0 \text{ V}, I_{\text{Diode}} = 5.0 \text{ A},$ $dI_{\text{Diode}}/dt = 100 \text{ A}/\mu\text{s}$		65		

#### Supply Section

I <sub>LK</sub>	Offset Supply Leakage Current	$HV_{CC} = V_{CTR} = 500 \text{ V}$			50	μA
I <sub>QH<sub>CC</sub></sub>	Quiescent HV <sub>CC</sub> Supply Current	$(HV_{CC}UV+) - 0.1 \text{ V}$		50	120	μA
I <sub>QL<sub>CC</sub></sub>	Quiescent LV <sub>CC</sub> Supply Current	$(LV_{CC}UV+) - 0.1 \text{ V}$		100	200	μA
I <sub>OH<sub>CC</sub></sub>	Operating HV <sub>CC</sub> Supply Current (RMS Value)	$f_{OSC} = 100 \text{ kHz}$		6	9	mA
		No Switching		100	200	μA
I <sub>OL<sub>CC</sub></sub>	Operating LV <sub>CC</sub> Supply Current (RMS Value)	$f_{OSC} = 100 \text{ kHz}$		7	11	mA
		No Switching		2	4	mA

#### UVLO Section

LV <sub>CC</sub> UV+	LV <sub>CC</sub> Supply Under-Voltage Positive-Going Threshold (LV <sub>CC</sub> Start)	11.2	12.5	13.8		V
LV <sub>CC</sub> UV-	LV <sub>CC</sub> Supply Under-Voltage Negative-Going Threshold (LV <sub>CC</sub> Stop)	8.9	10.0	11.1		V
LV <sub>CC</sub> UVH	LV <sub>CC</sub> Supply Under-Voltage Hysteresis		2.50			V
HV <sub>CC</sub> UV+	HV <sub>CC</sub> Supply Under-Voltage Positive-Going Threshold (HV <sub>CC</sub> Start)	8.2	9.2	10.2		V
HV <sub>CC</sub> UV-	HV <sub>CC</sub> Supply Under-Voltage Negative-Going Threshold (HV <sub>CC</sub> Stop)	7.8	8.7	9.6		V
HV <sub>CC</sub> UVH	HV <sub>CC</sub> Supply Under-Voltage Hysteresis		0.5			V

#### Oscillator & Feedback Section

V <sub>RT</sub>	V-I Converter Threshold Voltage	$R_T = 5.2 \text{ k}\Omega$	1.5	2.0	2.5	V
f <sub>OSC</sub>	Output Oscillation Frequency		94	100	106	kHz
DC	Output Duty Cycle		48	50	52	%
f <sub>SS</sub>	Internal Soft-Start Initial Frequency	$f_{SS} = f_{OSC} + 40 \text{ kHz},$ $R_T = 5.2 \text{ k}\Omega$		140		kHz
t <sub>SS</sub>	Internal Soft-Start Time		2	3	4	ms

## FLS-XS Series

### ELECTRICAL CHARACTERISTICS ( $T_A = 25^\circ\text{C}$ unless otherwise specified) (continued)

Symbol	Parameter	Condition	Min	Typ	Max	Unit
<b>Protection Section</b>						
$V_{C_{SS}H}$	Beginning Voltage to Discharge $C_{SS}$		0.9	1.0	1.1	V
$V_{C_{SS}L}$	Beginning Voltage to Charge $C_{SS}$ and Restart		0.16	0.20	0.24	V
$V_{OVP}$	$LV_{CC}$ Over-Voltage Protection	$LV_{CC} > 21\text{ V}$	21	23	25	V
$V_{AOCP}$	AOCP Threshold Voltage		-1.0	-0.9	-0.8	V
$t_{BAO}$	AOCP Blanking Time (Note 6)	$V_{CS} < V_{AOCP}$		50		ns
$V_{OCP}$	OCP Threshold Voltage		-0.64	-0.58	-0.52	V
$t_{BO}$	OCP Blanking Time (Note 6)	$V_{CS} < V_{OCP}$	1.0	1.5	2.0	$\mu\text{s}$
$t_{DA}$	Delay Time (Low Side) Detecting from $V_{AOCP}$ to Switch Off (Note 6)			250	400	ns
$T_{SD}$	Thermal Shutdown Temperature (Note 6)		+120	+135	+150	$^\circ\text{C}$

#### Dead-Time Control Section

$D_T$	Dead Time (Note 7)			350		ns
-------	--------------------	--	--	-----	--	----

Product parametric performance is indicated in the Electrical Characteristics for the listed test conditions, unless otherwise noted. Product performance may not be indicated by the Electrical Characteristics if operated under different conditions.

6. This parameter, although guaranteed by design, is not tested in production.

7. These parameters, although guaranteed, are tested only in EDS (wafer test) process.

# FLS-XS Series

## TYPICAL PERFORMANCE CHARACTERISTICS

(These characteristic graphs are normalized at  $T_A = 25^\circ\text{C}$ )

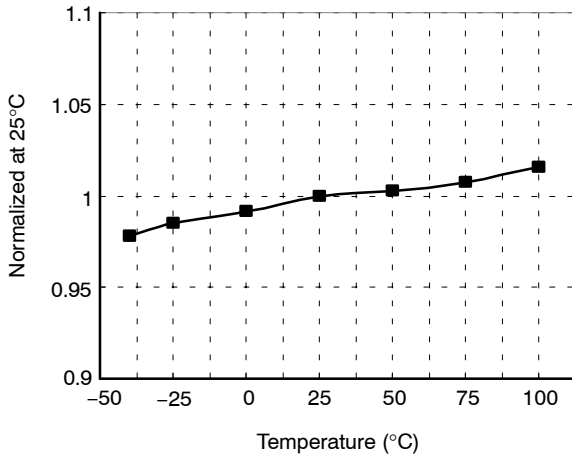

**Figure 4. Low-Side MOSFET Duty Cycle vs. Temperature**

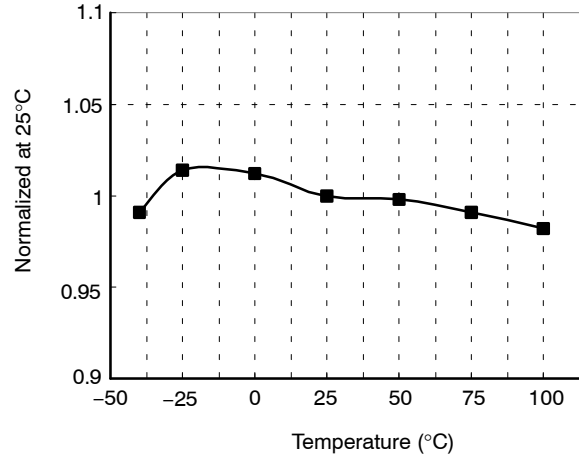

**Figure 5. Switching Frequency vs. Temperature**

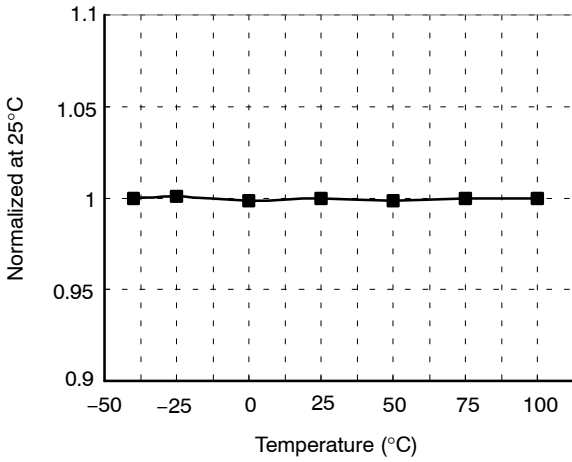

**Figure 6. High-Side  $V_{CC}$  ( $HV_{CC}$ ) Start vs. Temperature**

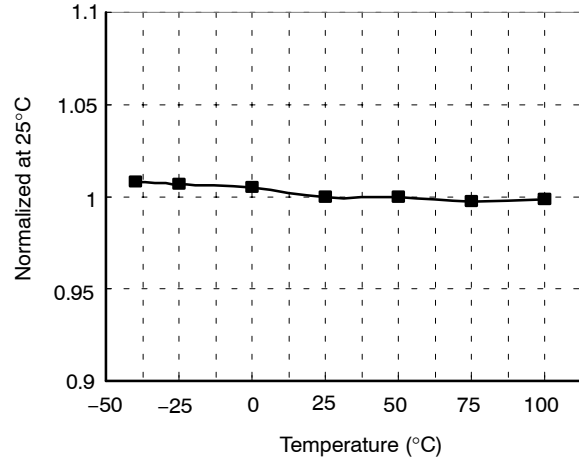

**Figure 7. High-Side  $V_{CC}$  ( $HV_{CC}$ ) Stop vs. Temperature**

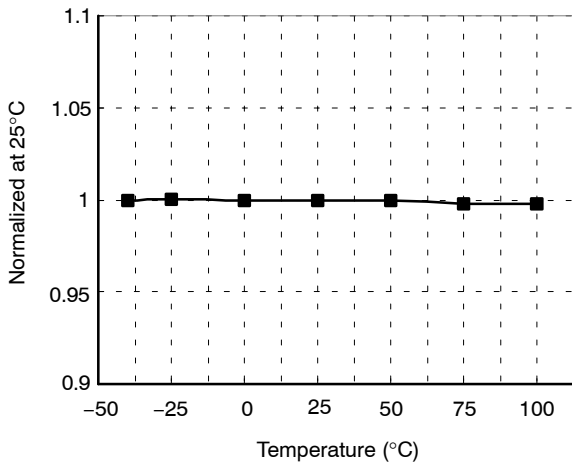

**Figure 8. Low-Side  $V_{CC}$  ( $LV_{CC}$ ) Start vs. Temperature**

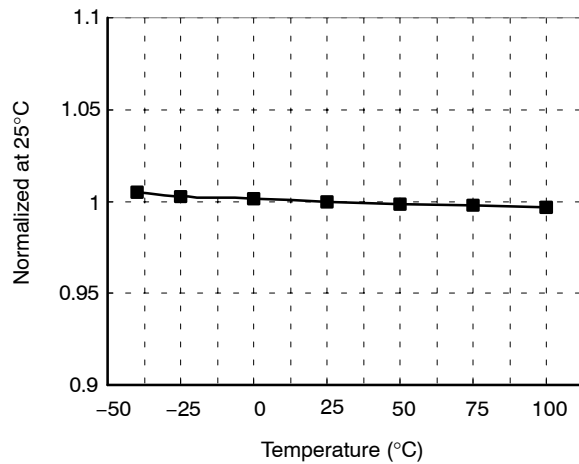

**Figure 9. Low-Side  $V_{CC}$  ( $LV_{CC}$ ) Stop vs. Temperature**



# FLS-XS Series

## TYPICAL PERFORMANCE CHARACTERISTICS

(These characteristic graphs are normalized at  $T_A = 25^\circ\text{C}$ ) (continued)

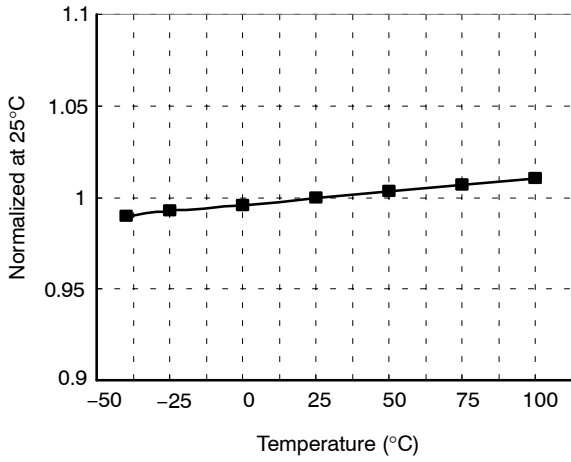

Figure 10. LV<sub>CC</sub> OVP Voltage vs. Temperature

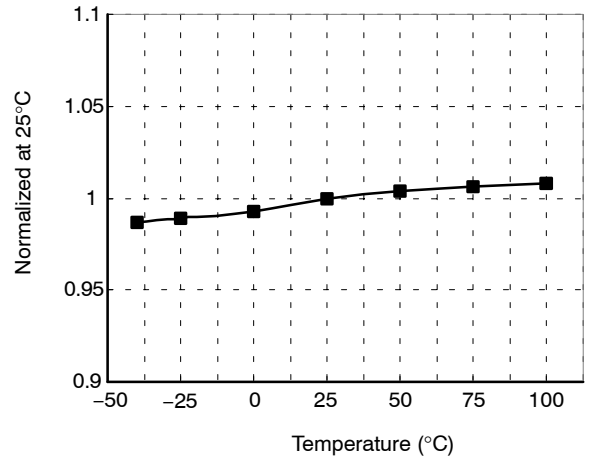

Figure 11. R<sub>T</sub> Voltage vs. Temperature

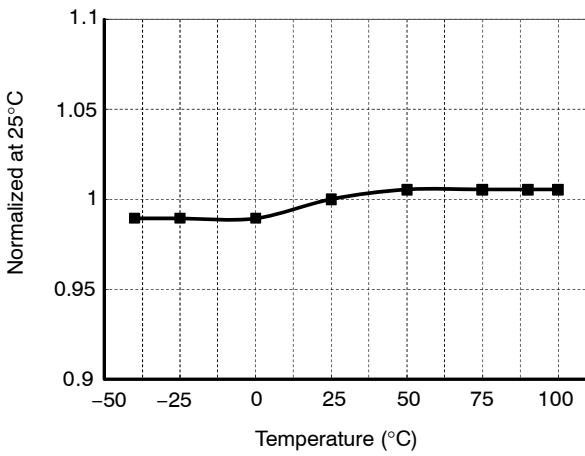

Figure 12. V<sub>CssL</sub> vs. Temperature

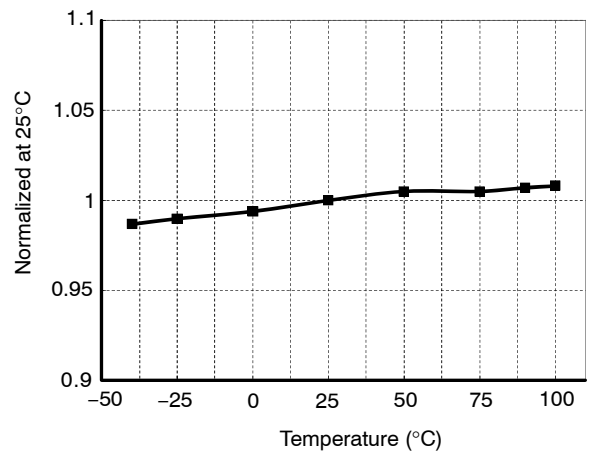

Figure 13. V<sub>CssH</sub> vs. Temperature

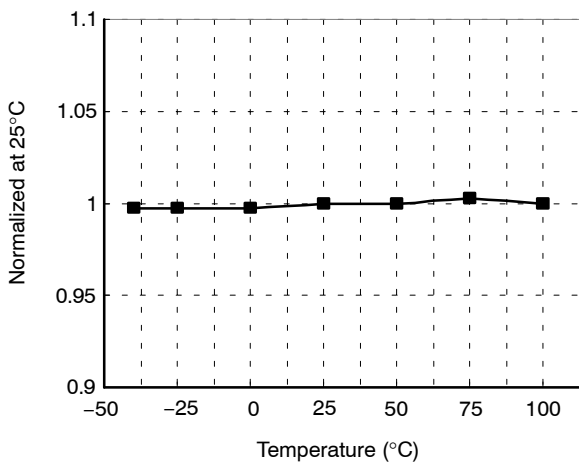
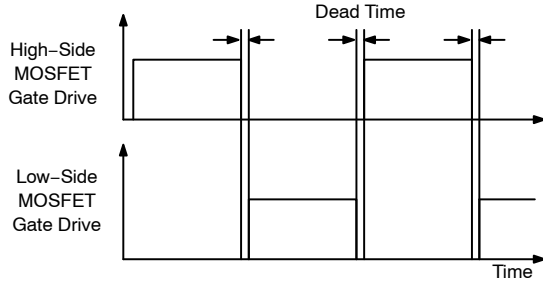

Figure 14. OCP Voltage vs. Temperature

**Functional Description**

*Basic Operation.*

FLS-XS series is designed to drive high-side and low-side MOSFETs complementarily with 50% duty cycle. A fixed dead time of 350 ns is introduced between consecutive transitions, as shown in Figure 15.



**Figure 15. MOSFETs Gate Drive Signal**

*Internal Oscillator:*

FLS-XS series employs a current-controlled oscillator, as shown in Figure 16. Internally, the voltage of the  $R_T$  pin is regulated at 2 V and the charging / discharging current for the oscillator capacitor,  $C_T$ , is obtained by copying the current flowing out of the  $R_T$  pin ( $I_{CTC}$ ) using a current mirror. Therefore, the switching frequency increases as  $I_{CTC}$  increases.

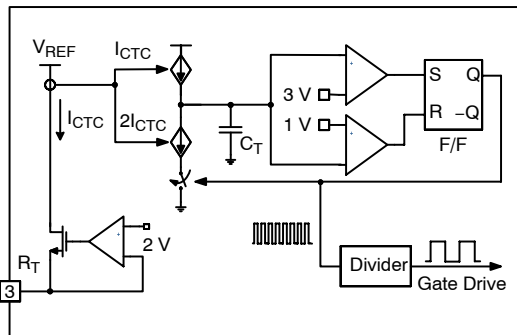

**Figure 16. Current-Controlled Oscillator**

*Frequency Setting:*

Figure 17 shows the typical voltage gain curve of a resonant converter, where the gain is inversely proportional to the switching frequency in the ZVS region. The output voltage can be regulated by modulating the switching frequency. Figure 18 shows the typical circuit configuration for the  $R_T$  pin, where the opto-coupler transistor is connected to the  $R_T$  pin to modulate the switching frequency.

The minimum switching frequency is determined as:

$$f_{min} = \frac{5.2 \text{ k}\Omega}{R_{min}} \times 100 \text{ (kHz)} \quad (\text{eq. 1})$$

Assuming the saturation voltage of opto-coupler transistor is 0.2 V, the maximum switching frequency is determined as:

$$f_{max} = \left( \frac{5.2 \text{ k}\Omega}{R_{min}} + \frac{4.68 \text{ k}\Omega}{R_{max}} \right) \times 100 \text{ (kHz)} \quad (\text{eq. 2})$$

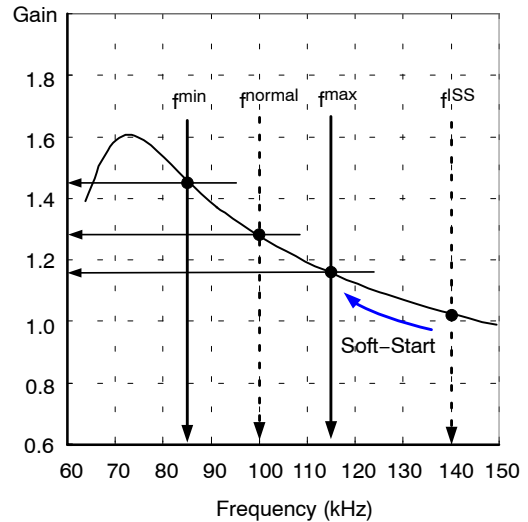

**Figure 17. Resonant Converter Typical Gain Curve**

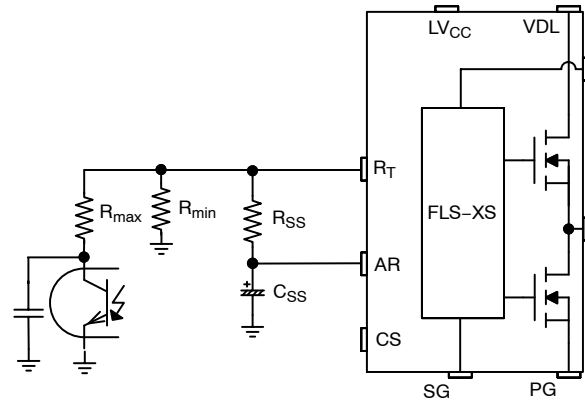

**Figure 18. Frequency Control Circuit**

To prevent excessive inrush current and overshoot of output voltage during startup, increase the voltage gain of the resonant converter progressively. Since the voltage gain of the resonant converter is inversely proportional to the switching frequency, the soft-start is implemented by sweeping down the switching frequency from an initial high frequency ( $f^{SS}$ ) until the output voltage is established. The soft-start circuit is made by connecting R-C series network on the  $R_T$  pin, as shown in Figure 18. FLS-XS series also has a 3 ms internal soft-start to reduce the current overshoot during the initial cycles, which adds 40 kHz to the initial frequency of the external soft-start circuit, as shown in Figure 19. The initial frequency of the soft-start is given as:

$$f^{SS} = \left( \frac{5.2 \text{ k}\Omega}{R_{min}} + \frac{5.2 \text{ k}\Omega}{R_{SS}} \right) \times 100 + 40 \text{ (kHz)} \quad (\text{eq. 3})$$

## FLS-XS Series

It is typical to set the initial frequency of soft-start two to three times the resonant frequency ( $f_0$ ) of the resonant network. The soft-start time is three to four times the RC time constant. The RC time constant is:

$$\tau = R_{SS} \cdot C_{SS} \quad (\text{eq. 4})$$

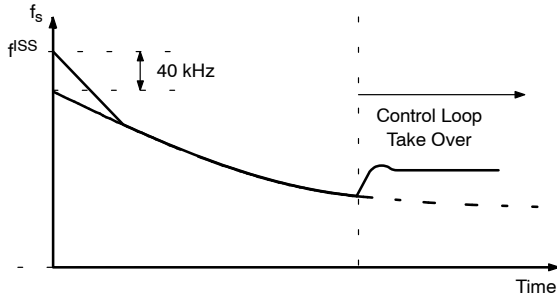

**Figure 19. Frequency Sweeping of Soft-Start**

### Self Auto-Restart:

The FLS-XS series can restart automatically even when any built-in protections are triggered with external supply voltage. As can be seen in Figure 20 and Figure 21, once a protection is triggered, the M1 switch turns on and the V-I converter is disabled.  $C_{SS}$  starts to discharge until  $V_{C_{SS}}$  across  $C_{SS}$  drops to  $V_{C_{SSL}}$ . Then, all protections are reset, M1 turns off, and the V-I converter resumes. The FLS-XS starts switching again with soft-start. If the protections occur while  $V_{C_{SS}}$  is under  $V_{C_{SSL}}$  and  $V_{C_{SSH}}$  level, the switching is terminated immediately,  $V_{C_{SS}}$  continues to increase until reaching  $V_{C_{SSH}}$ , then  $C_{SS}$  is discharged by M1.

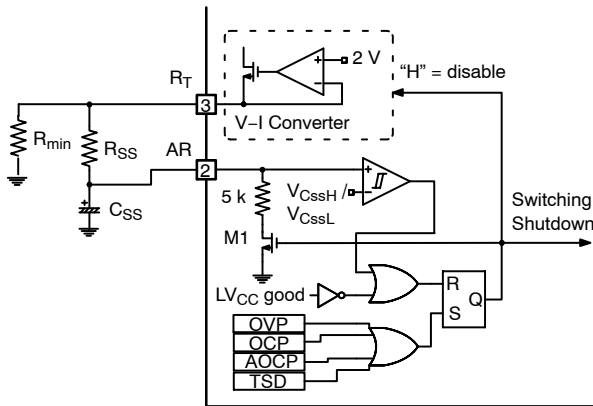
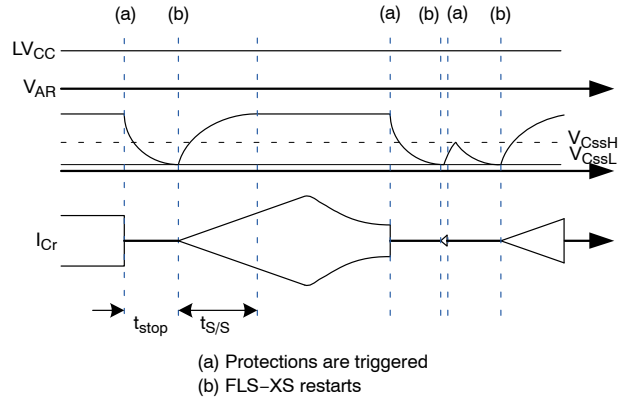

**Figure 20. Frequency Control Circuit**

After protections trigger, FLS-XS is disabled during the stop-time,  $t_{STOP}$ , where  $V_{C_{SS}}$  decreases and reaches to  $V_{C_{SSL}}$ . The stop-time of FLS-XS can be estimated as:

$$t_{STOP} = C_{SS} \cdot \left\{ (R_{SS} + R_{MIN}) \parallel 5 \text{ k}\Omega \right\} \quad (\text{eq. 5})$$

The soft-start time  $t_{S/S}$  can be set from Equation 4.

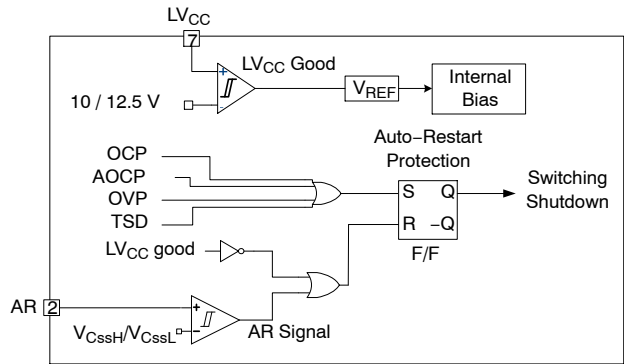

**Figure 21. Self Auto-Restart Operation**

### Protection Circuits:

The FLS-XS series has several self-protective functions, such as Over-Current Protection (OCP), Abnormal Over-Current Protection (AOCP), Over-Voltage Protection (OVP), and Thermal Shutdown (TSD). These protections are auto-restart-mode protections, as shown in Figure 22.

Once a fault condition is detected, switching is terminated and the MOSFETs remain off. When  $LV_{CC}$  falls to the  $LV_{CC}$  stop voltage of 10 V or AR signal is HIGH, the protection is reset. The FLS-XS resumes normal operation when  $LV_{CC}$  reaches the start voltage of 12.5 V.



**Figure 22. Protection Blocks**

**Over-Current Protection (OCP):** When the sensing pin voltage drops below  $-0.58 \text{ V}$ , OCP is triggered and the MOSFETs remain off. This protection has a shutdown time delay of  $1.5 \mu\text{s}$  to prevent premature shutdown during startup.

**Abnormal Over-Current Protection (AOCP):** If the secondary rectifier diodes are shorted, large current with extremely high  $di/dt$  can flow through the MOSFET before OCP is triggered. AOCP is triggered without shutdown delay if the sensing pin voltage drops below  $-0.9 \text{ V}$ .

## FLS-XS Series

**Over-Voltage Protection (OVP):** When the  $V_{CC}$  reaches 23 V, OVP is triggered. This protection is used when auxiliary winding of the transformer to supply  $V_{CC}$  to the power switch is utilized.

**Thermal Shutdown (TSD):** Having the MOSFETs and the control IC in one package makes it easier for the control IC to detect the abnormal over-temperature of the MOSFETs. If the temperature exceeds approximately  $130^{\circ}\text{C}$ , thermal shutdown triggers.

### Current Sensing Using a Resistor:

FLS-XS series senses drain current as a negative voltage, as shown in Figure 23 and Figure 24. Half-wave sensing allows low power dissipation in the sensing resistor; while full-wave sensing has less switching noise in the sensing signal.

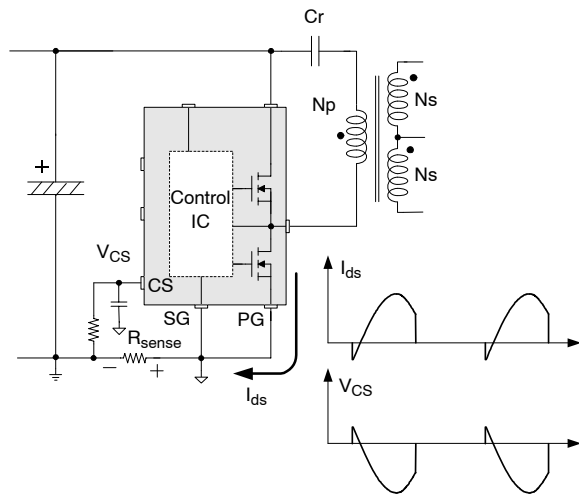

Figure 23. Half-Wave Sensing

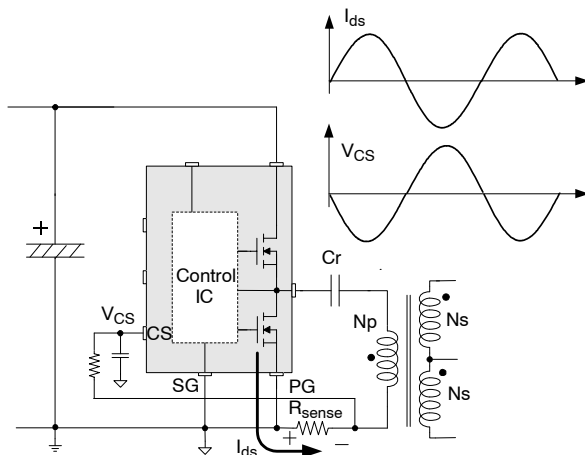

Figure 24. Full-Wave Sensing

### PCB Layout Guidelines:

Duty imbalance problems may occur due to the radiated noise from the main transformer, the inequality of the secondary side-leakage inductances of main transformer, and so on. This is one of the reasons that the control components in the vicinity of  $R_T$  pin are enclosed by the primary current flow pattern on PCB layout. The direction of the magnetic field on the components caused by the primary current flow is changed when the high- and low-side MOSFET turn on by turns. The magnetic fields with opposite directions induce a current through, into, or out of the  $R_T$  pin, which changes the turn-on duration of each MOSFET. It is strongly recommended to separate the control components in the vicinity of  $R_T$  pin from the primary current flow pattern on PCB layout. Figure 25 shows an example for the duty-balanced case.

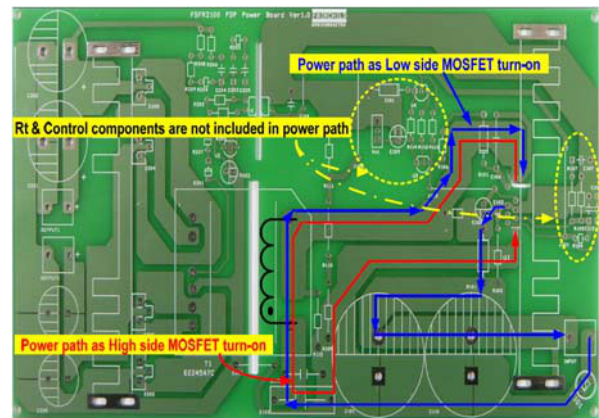

Figure 25. Example for Duty Balancing

# MECHANICAL CASE OUTLINE

## PACKAGE DIMENSIONS

ON Semiconductor®



SIP9 26x10.5  
CASE 127EM  
ISSUE O

DATE 31 DEC 2016

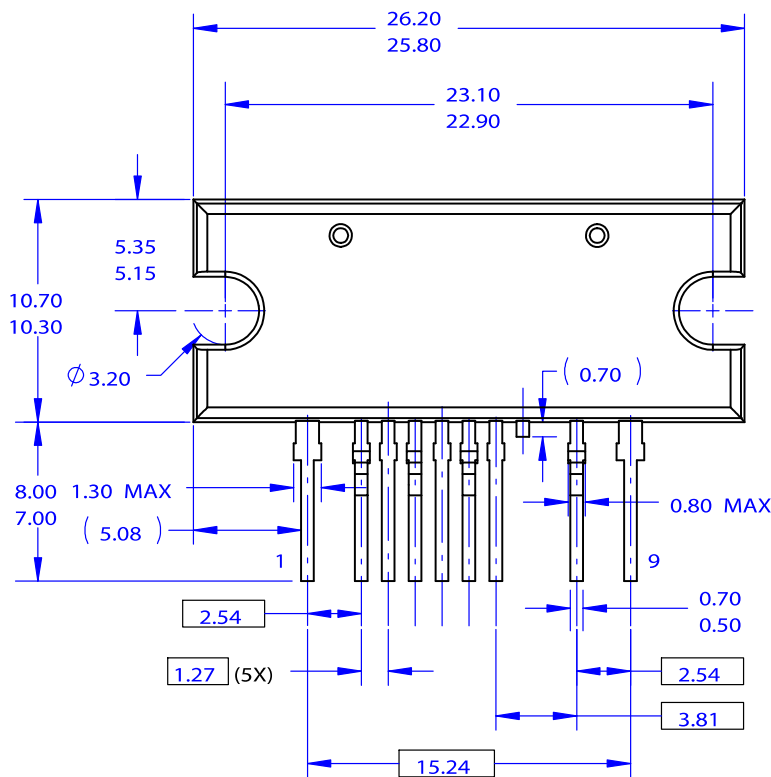

FRONT VIEW

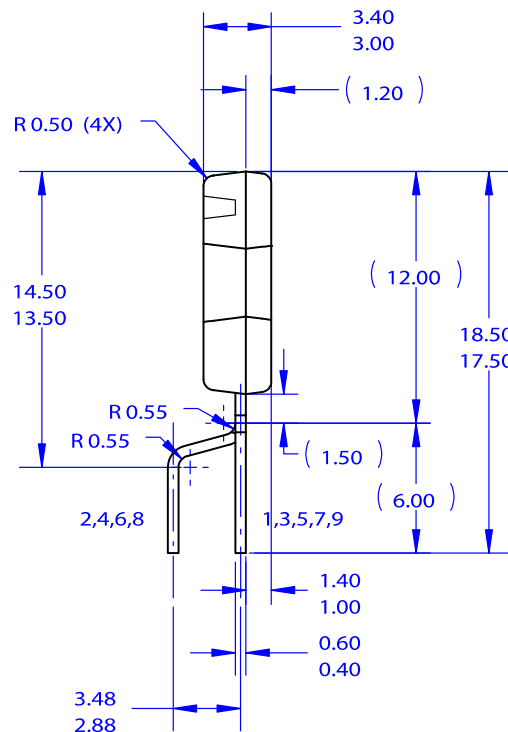

RIGHT SIDE VIEW

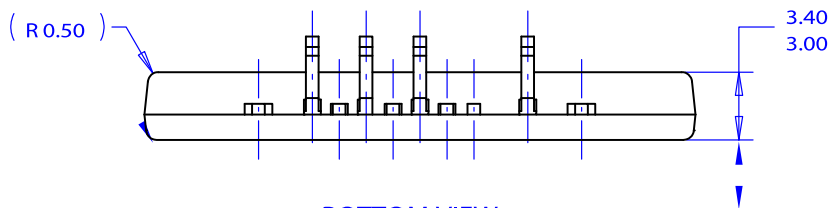

BOTTOM VIEW

NOTES: UNLESS OTHERWISE SPECIFIED

- A. THIS PACKAGE DOES NOT COMPLY TO ANY CURRENT PACKAGING STANDARD.
- B. ALL DIMENSIONS ARE IN MILLIMETERS.
- C. DIMENSIONS ARE EXCLUSIVE OF BURRS, MOLD FLASH AND TIE BAR PROTRUSIONS.

DOCUMENT NUMBER:	98AON13718G	Electronic versions are uncontrolled except when accessed directly from the Document Repository. Printed versions are uncontrolled except when stamped "CONTROLLED COPY" in red.
DESCRIPTION:	SIP9 26x10.5	PAGE 1 OF 1

ON Semiconductor and ON are trademarks of Semiconductor Components Industries, LLC dba ON Semiconductor or its subsidiaries in the United States and/or other countries. ON Semiconductor reserves the right to make changes without further notice to any products herein. ON Semiconductor makes no warranty, representation or guarantee regarding the suitability of its products for any particular purpose, nor does ON Semiconductor assume any liability arising out of the application or use of any product or circuit, and specifically disclaims any and all liability, including without limitation special, consequential or incidental damages. ON Semiconductor does not convey any license under its patent rights nor the rights of others.