

SURFACE MOUNT

GLASS PASSIVATED SILICON RECTIFIER

VOLTAGE RANGE 50 to 1000 Volts CURRENT 2.0 Amperes

FEATURES

- * Glass passivated device
- * Ideal for surface mounted applications
- * Low leakage current
- * Metallurgically bonded construction
- * Mounting position: Any
- * Weight: 0.098 gram
- * P/N suffix V means AEC-Q101 qualified, e.g:FM201V
- * P/N suffix V means Halogen-free

MECHANICAL DATA

- * Epoxy : Device has UL flammability classification 94V-0

DO-214AA

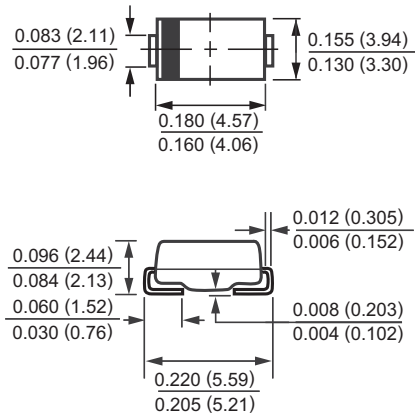

Dimensions in inches and (millimeters)

MAXIMUM RATINGS AND ELECTRICAL CHARACTERISTICS

Ratings at 25 °C ambient temperature unless otherwise specified.
Single phase, half wave, 60 Hz, resistive or inductive load.
For capacitive load, derate current by 20%.

MAXIMUM RATINGS (At TA = 25°C unless otherwise noted)

RATINGS	SYMBOL	FM201	FM202	FM203	FM204	FM205	FM206	FM207	UNITS
Maximum Recurrent Peak Reverse Voltage	V _{RRM}	50	100	200	400	600	800	1000	Volts
Maximum RMS Voltage	V _{RMS}	35	70	140	280	420	560	700	Volts
Maximum DC Blocking Voltage	V _{DC}	50	100	200	400	600	800	1000	Volts
Maximum Average Forward Rectified Current at TA = 75°C	I _O	2.0							Amps
Peak Forward Surge Current 8.3 ms single half sine-wave superimposed on rated load (JEDEC method)	I _{FSM}	60							Amps
Typical Current Squared Time	I ² T	15							A ² S
Typical Thermalresistance	(Note 2)R _{θJL}	20							°C/W
	(Note 3)R _{θJA}	50							°C/W
Typical Junction Capacitance (Note 1)	C _J	30							pF
Operating and Storage Temperature Range	T _J ,T _{STG}	-65 to + 175							°C

ELECTRICAL CHARACTERISTICS (At TA = 25°C unless otherwise noted)

CHARACTERISTICS	SYMBOL	FM201	FM202	FM203	FM204	FM205	FM206	FM207	UNITS
Maximum Instantaneous Forward Voltage at 2.0A DC	V _F	1.0							Volts
Maximum Average Reverse Current at Rated DC Blocking Voltage	@TA = 25°C	1.0							uAmps
	@TA = 150°C	800							uAmps

- NOTES : 1. Measured at 1 MHz and applied reverse voltage of 4.0 volts.
2. Thermal resistance junction to terminal, 5X5mm² copper pads to each terminal.
3. Thermal resistance junction to ambient, 5X5mm² copper pads to each terminal.

RATING AND CHARACTERISTIC CURVES(FM201 THRU FM207)

FIG. 1 - TYPICAL FORWARD CURRENT DERATING CURVE

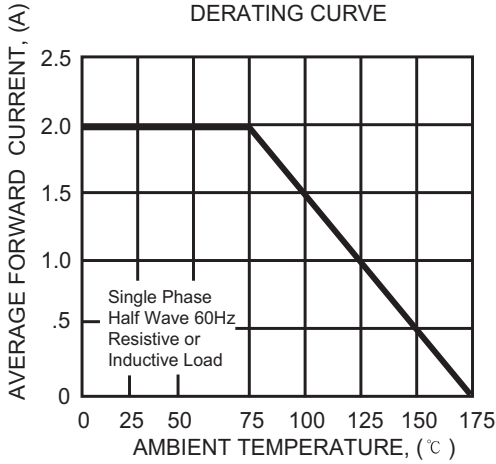

FIG. 2 - MAXIMUM INSTANTANEOUS FORWARD CHARACTERISTICS

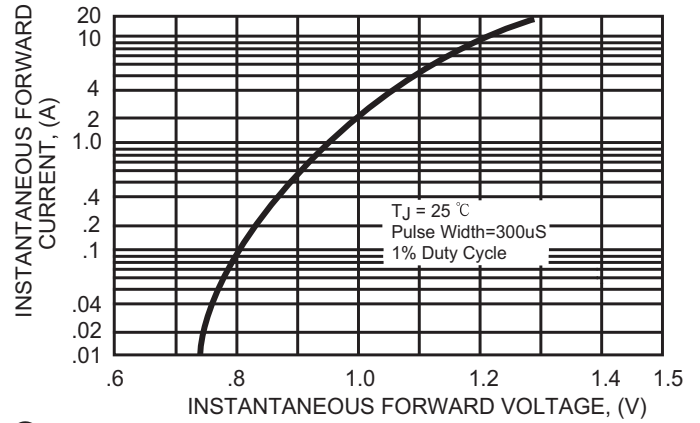

FIG. 3 - MAXIMUM NON-REPETITIVE FORWARD SURGE CURRENT

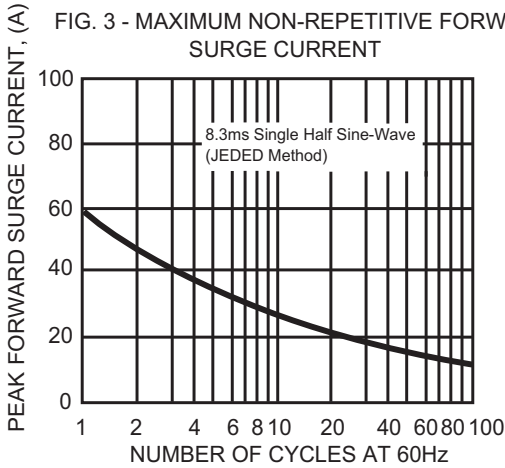

FIG. 4 - MAXIMUM REVERSE CHARACTERISTICS

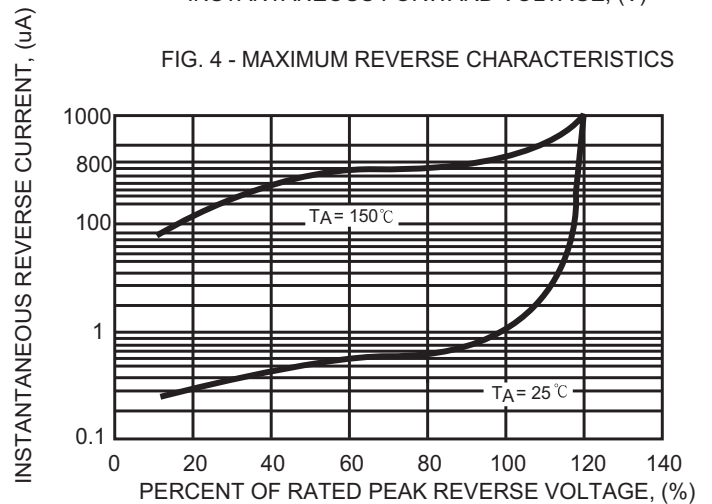
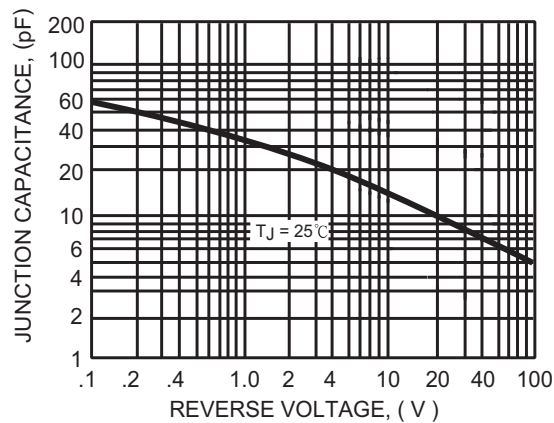
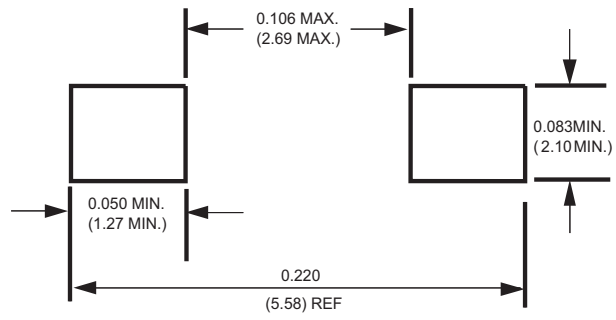

FIG. 5 - TYPICAL JUNCTION CAPACITANCE



Mounting Pad Layout



Dimensions in inches and (millimeters)

Marking Description

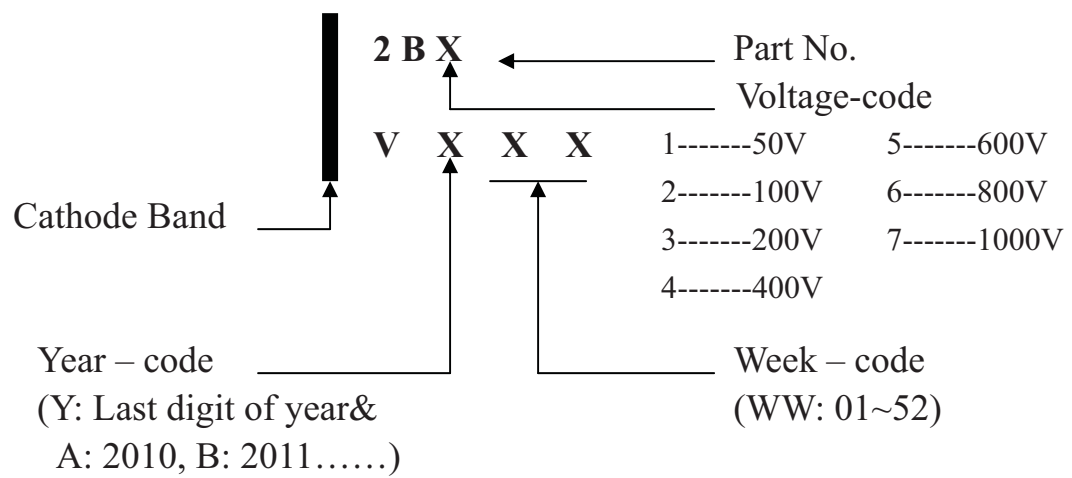

PACKAGING OF DIODE AND BRIDGE RECTIFIERS

REEL PACK

PACKAGE	PACKING CODE	EA PER REEL	EA PER INNER BOX	COMPONENT SPACE (mm)	TAPE SPACE (mm)	REEL DIA (mm)	CARTON SIZE (mm)	EA PER CARTON	GROSS WEIGHT(Kg)
SMB	-T	500	2,000	---	---	178	390*205*310	16,000	---
SMB	-W	3,000	6,000	---	---	330	360*355*360	48,000	13.90