

**SURFACE MOUNT
GLASS PASSIVATED SILICON RECTIFIER
VOLTAGE RANGE 50 to 1000 Volts CURRENT 5.0 Amperes**

FEATURES

- * Glass passivated device
- * Ideal for surface mounted applications
- * Low leakage current
- * Metallurgically bonded construction
- * P/N suffix V means AEC-Q101 qualified, e.g:FM501V
- * Halogen-free

MECHANICAL DATA

- * Epoxy : Device has UL flammability classification 94V-0
- * Mounting position: Any
- * Weight: 0.25 gram



SMC

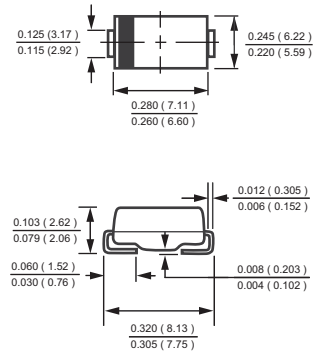

Dimensions in inches and (millimeters)

MAXIMUM RATINGS AND ELECTRICAL CHARACTERISTICS

Ratings at 25 °C ambient temperature unless otherwise specified.
resistive or inductive load.

MAXIMUM RATINGS (@ TA=25 °C unless otherwise noted)

RATINGS	SYMBOL	FM501	FM502	FM503	FM504	FM505	FM506	FM507	UNITS
Maximum Recurrent Peak Reverse Voltage	V_{RRM}	50	100	200	400	600	800	1000	Volts
Maximum RMS Voltage	V_{RMS}	35	70	140	280	420	560	700	Volts
Maximum DC Blocking Voltage	V_{DC}	50	100	200	400	600	800	1000	Volts
Maximum Average Forward Rectified Current TA = 75 °C	I_O	5.0							Amps
Peak Forward Surge Current 8.3 ms single half sine-wave superimposed on rated load (JEDEC method)	I_{FSM}	150							Amps
Typical Current Squared Time	I^2T	93.3							A ² S
Typical Thermal Resistance (Note 1)	$R_{\theta JA}$	35							°C/W
Typical Thermal Resistance (Note 1)	$R_{\theta JL}$	10							°C/W
Typical Junction Capacitance (Note 2)	C_J	60							pF
Operating Temperature Range	T_J	150							°C
Storage Temperature Range	T_{STG}	-55 to + 150							°C

ELECTRICAL CHARACTERISTICS(@TA=25 °C unless otherwise noted)

CHARACTERISTICS	SYMBOL	FM501	FM502	FM503	FM504	FM505	FM506	FM507	UNITS
Maximum Instantaneous Forward Voltage at 5.0A DC	V_F	1.1							Volts
Maximum Average Reverse Current	I_R	@TA = 25°C						5.0	μA
at Rated DC Blocking Voltage		@TA = 150°C						500	μA

- NOTES : 1. Thermal Resistance :Mounted on PCB.
2. Measured at 1 MHz and applied reverse voltage of 4.0 volts.
3. "ROHS compliant".

RATING AND CHARACTERISTICS CURVES (FM501 THRU FM507)

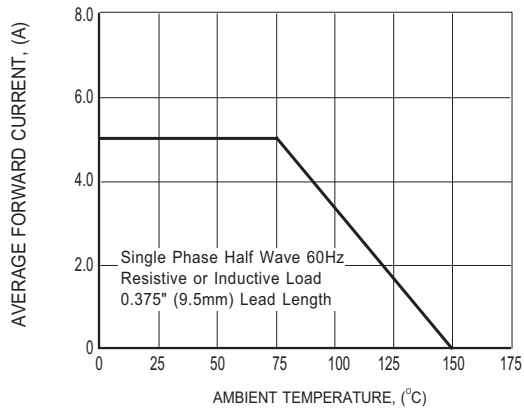

FIG.1 TYPICAL FORWARD CURRENT DERATING CURVE

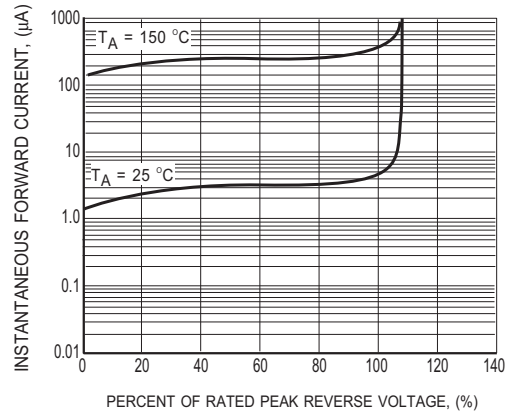

FIG.2 MAXIMUM REVERSE CHARACTERISTICS

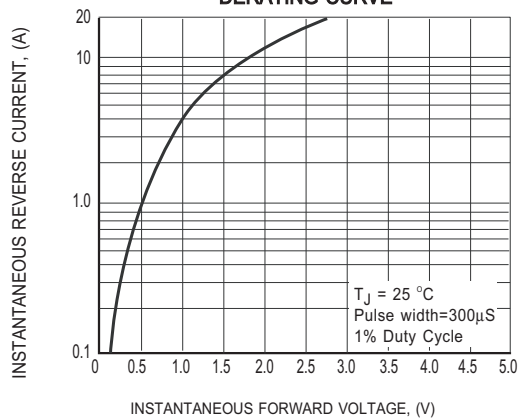

FIG.3 MAXIMUM INSTANTANEOUS FORWARD CHARACTERISTICS

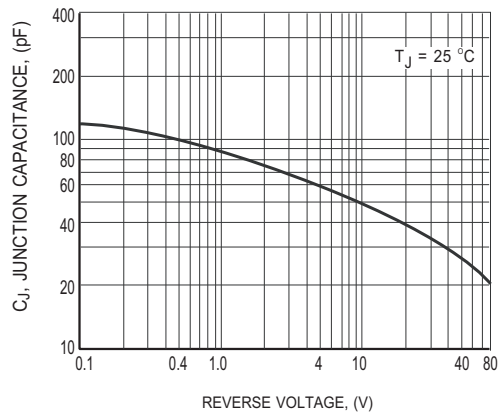

FIG.4 TYPICAL JUNCTION CAPACITANCE

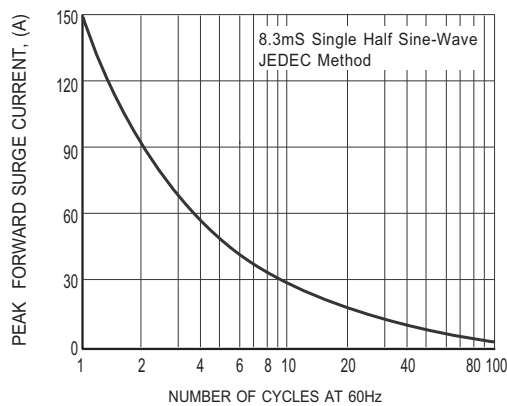
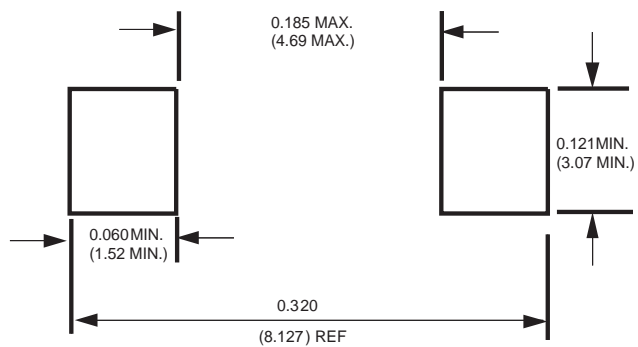

FIG.5 MAXIMUM NON-REPETITIVE FORWARD SURGE CURRENT

Mounting Pad Layout



Dimensions in inches and (millimeters)

Marking Description

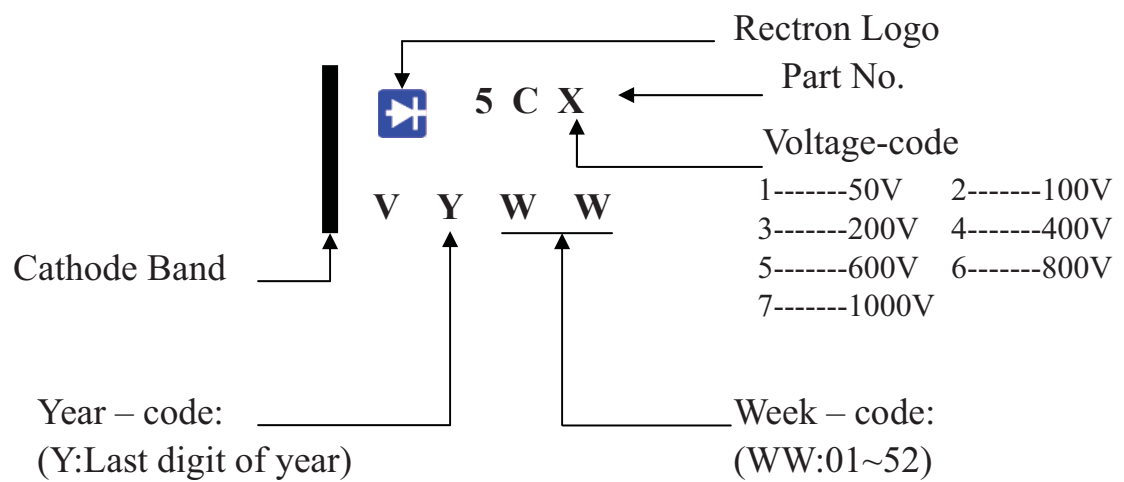

PACKAGING OF DIODE AND BRIDGE RECTIFIERS

REEL PACK

PACKAGE	PACKING CODE	EA PER REEL	EA PER INNER BOX	COMPONENT SPACE (mm)	TAPE SPACE (mm)	REEL DIA (mm)	CARTON SIZE (mm)	EA PER CARTON	GROSS WEIGHT(Kg)
SMC	-W/-T	3,000	3,000	---	---	330	360*355*360	24,000	11.50