

LOW Vf SCHOTTKY BARRIER RECTIFIER

VOLTAGE RANGE 20 to 40 Volts CURRENT 1.0 Ampere

FEATURES

- * Low switching noise
- * Low forward voltage drop
- * High current capability
- * High switching capability
- * High surge capability
- * High reliability

MECHANICAL DATA

- * Case: Molded plastic
- * Epoxy: Device has UL flammability classification 94V-0
- * Lead: MIL-STD-202E method 208C guaranteed
- * Metallurgically bonded construction
- * Mounting position: Any
- * Weight: 0.09 gram

MAXIMUM RATINGS AND ELECTRICAL CHARACTERISTICS

Ratings at 25 °C ambient temperature unless otherwise specified.
Resistive or inductive load.



DO-214AC

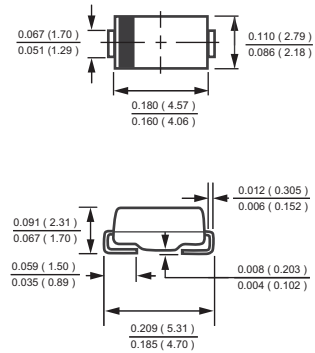

Dimensions in inches and (millimeters)

MAXIMUM RATINGS (@ TA=25 °C unless otherwise noted)

RATINGS	SYMBOL	FMM120	FMM130	FMM140	UNITS
Maximum Recurrent Peak Reverse Voltage	V_{RRM}	20	30	40	Volts
Maximum RMS Voltage	V_{RMS}	14	21	28	Volts
Maximum DC Blocking Voltage	V_{DC}	20	30	40	Volts
Maximum Average Forward Rectified Current at $T_A=75^{\circ}C$	I_O		1.0		Amps
Peak Forward Surge Current 8.3 ms single half sine-wave superimposed on rated load (JEDEC method)	I_{FSM}		40		Amps
Typical Current Square Time	I^2T		6.6		A ² S
Typical Thermal Resistance (Note 1)	$R_{\theta JA}$		85		°C/W
Typical Thermal Resistance (Note 1)	$R_{\theta JL}$		25		°C/W
Typical Junction Capacitance (Note 2)	C_J		110		pF
Operating Temperature Range	T_J		150		°C
Storage Temperature Range	T_{STG}		-55 to + 150		°C

ELECTRICAL CHARACTERISTICS (@TA=25 °C unless otherwise noted)

CHARACTERISTICS	SYMBOL	FMM120	FMM130	FMM140	UNITS
Maximum Instantaneous Forward Voltage at 1.0A DC	V_F		.44		Volts
Maximum Average Reverse Current at Rated DC Blocking Voltage	@ $T_A = 25^{\circ}C$		1.0		mA
	@ $T_A = 150^{\circ}C$		20		mA

- NOTES : 1. Thermal Resistance : Mounted on PCB.
2. Measured at 1 MHz and applied reverse voltage of 4.0 volts.
3. Also available in DO-214AA (SMB).

RATING AND CHARACTERISTICS CURVES (FMM120 THRU FMM140)

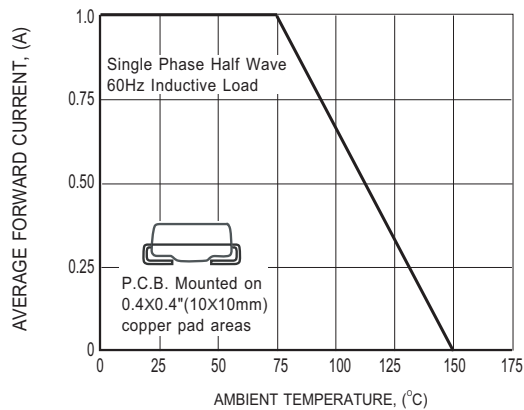

FIG.1 TYPICAL FORWARD CURRENT DERATING CURVE

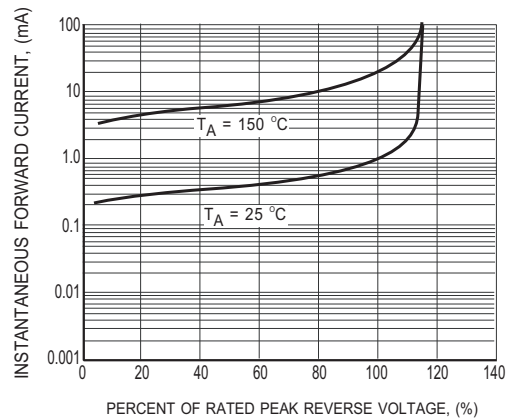

FIG.2 MAXIMUM REVERSE CHARACTERISTICS

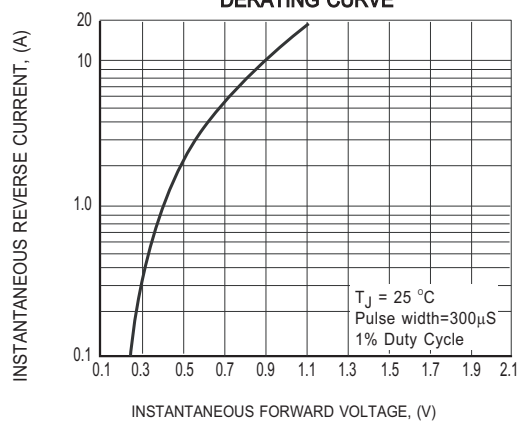

FIG.3 MAXIMUM INSTANTANEOUS FORWARD CHARACTERISTICS

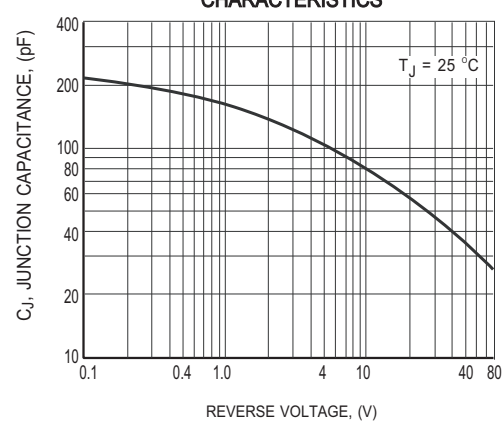

FIG.4 TYPICAL JUNCTION CAPACITANCE

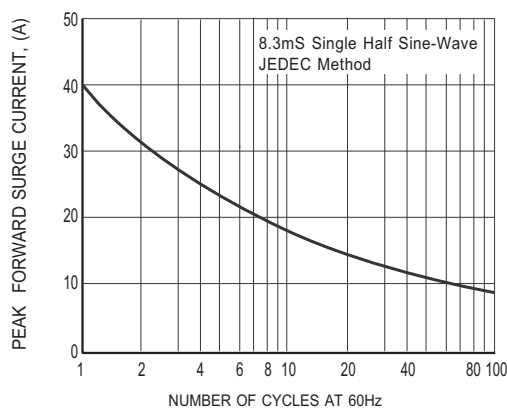
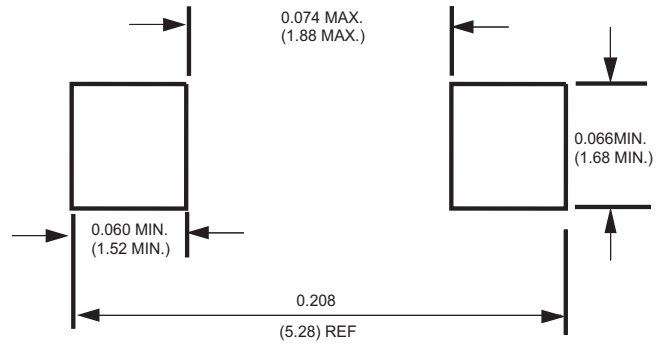

FIG.5 MAXIMUM NON-REPETITIVE FORWARD SURGE CURRENT

Mounting Pad Layout



Dimensions in inches and (millimeters)

Marking Description

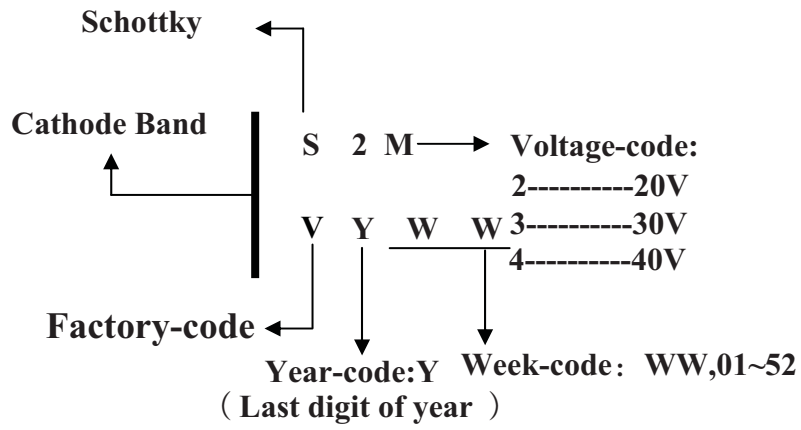

PACKAGING OF DIODE AND BRIDGE RECTIFIERS

REEL PACK

PACKAGE	PACKING CODE	EA PER REEL	EA PER INNER BOX	COMPONENT SPACE (mm)	TAPE SPACE (mm)	REEL DIA (mm)	CARTON SIZE (mm)	EA PER CARTON	GROSS WEIGHT(Kg)
SMA	-W	7,500	15,000	---	---	330	360*355*360	120,000	15.2

PACKAGE	PACKING CODE	EA PER REEL	EA PER INNER BOX	COMPONENT SPACE (mm)	TAPE SPACE (mm)	REEL DIA (mm)	CARTON SIZE (mm)	EA PER CARTON	GROSS WEIGHT(Kg)
SMA	-T	2,000	8,000	---	---	178	390*205*310	64,000	7.8