

Ecosine evo, 400 VAC 60 Hz Passive Harmonic Filters for 6-pulse rectifier with 8% DC-Link choke

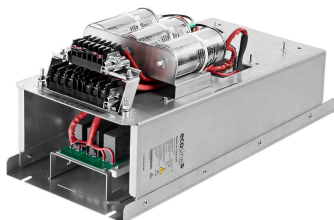

- The industry standard for 6-pulse rectifier and motor drives
- Filters for diode rectifier with DC-link choke
- Best-in-class partial load performance
- Most compact design
- Plug and play, ready to use



Approvals & Compliances



(depending on filter configuration)

Features and benefits

Schaffner ecosine harmonic filters represent an economical solution to the challenge of load-applied harmonics mitigation in three-phase power systems. With a plug-and-play approach and more compact dimensions than comparable products, they can be quickly installed and easily commissioned. They increase the reliability and service life of electric installations, help utilize electric system capacity better, and are the key to meet Power Quality standards such as IEEE 519. Ecosine filters reshape your distorted current back to the desired sinusoidal waveform. Schaffner ecosine filters can be applied to virtually any kind of power electronics with front-end six-pulse rectifiers, 3-phase diode or thyristor bridges, where harmonic current distortion needs to be reduced to defined limits.

Typical applications

- Equipment with front-end six-pulse rectifier
- Motor drives
- Factory automation equipment
- Water/wastewater treatment facilities
- Fan and pump applications
- HVAC installations
- Mission-critical processes
- DC fast chargers

Technical specifications

Nominal operating voltage	3x380 VAC to 415 VAC ± 10%
Operating frequency	60 Hz ± 1 Hz
Nominal motor drive input power rating	1 to 240 HP
Total harmonic current distortion THDi*	<5% at rated power
Efficiency	>98% for rated voltage and power
Overload capability	1.6x rated current for 1 minute, once per hour
SCCR**	100 kA
Earthing System	TN, TT, IT
Protection category	IP 00, IP 20****
Cooling	Internal fan cooling or external cooling***
Ambient temperature range	-25°C to +45°C fully operational +45°C to +70°C derated operation**** -25°C to +85°C transport and storage
Design corresponding to	Filter: UL 61800-5-1, EN 61800-5-1 Chokes: EN 61558-2-20 or EN 60076-6
Flammability corresponding to	UL 94 V-2
MTBF @ 45°C/400 V (Mil-HB-217F)	>200,000 hours

* System requirements: THDv <2%, line voltage unbalance <1%
 Note: performance specifications in this brochure refer to six-pulse diode rectifiers with 8% DC-link choke. THDi ~5% at rated power for filter <6 kW/HP
 ** External UL-rated fuses required. Please consult the user manual.
 *** Please check the inlet air flow required for cooling table further in this document and the user manual.
 **** $I_{derated} = I_{nominal} \cdot \sqrt{\frac{(T_{max} - T_{amb})}{(T_{max} - T_{nominal})}} = I_{nominal} \cdot \sqrt{\frac{(70^\circ\text{C} - T_{amb})}{25^\circ\text{C}}}$

Typical electrical schematic

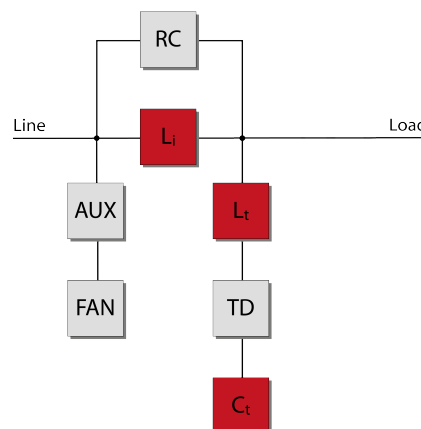

(all configurable optional functionalities shown)

Filter selection table @ 380 V / 60 Hz – IP 00 enclosure

Filter	Rated load power @ 380V/60 Hz		Motor drive input current [Arms]***	Rated filter input current [Arms]	Min. required LDC [mH]*****	Min. required LAC [mH]*****	Weight		Typical losses [W]****	Terminal	Frame size
	[kW]	[HP]					[kg]	[lbs]			
FN 3443-1-110-E0_*****	0.9	1.2	1.4	1.37	21.5	11.61	5	11	41	110	A
FN 3443-2-110-E0_*****	1.7	2.4	2.9	2.74	18.2	6.145	7	15	53	110	A
FN 3443-4-112-E0_*****	2.9	4	4.8	4.52	10.7	3.602	9	20	88	112	B
FN 3443-6-112-E0_*****	4.5	6	7.2	6.85	7.04	2.374	12	25	101	112	B
FN 3443-8-112-E0_*****	5.9	8	9.6	9.20	5.25	1.771	14	30	123	112	C
FN 3443-12-112-E0_*****	8.7	12	14.4	13.7	3.56	1.201	16	34	183	112	C
FN 3443-16-113-E0_****	11.9	16	19.3	18.3	2.61	0.880	23	51	228	113	D
FN 3443-20-113-E0_****	14.9	20	24.0	23.0	2.06	0.696	26	56	277	113	D
FN 3443-24-113-E0_****	17.4	24	29.0	27.5	1.78	0.600	30	66	282	113	D
FN 3443-32-115-E0_****	23.8	32	38.5	36.8	1.30	0.434	37	82	370	115	E
FN 3443-40-115-E0_****	29.3	40	48.0	45.8	1.06	0.357	42	92	453	115	E
FN 3443-48-115-E0_****	35.6	48	58.0	55	0.869	0.293	48	106	476	115	E
FN 3443-60-115-E0_****	44.3	60	72.0	69	0.699	0.236	49	108	634	115	F
FN 3443-80-115-E0_****	59.4	80	97.0	92	0.521	0.176	68	149	779	115	F
FN 3443-100-116-E0_****	73.6	100	120	114	0.421	0.142	97	214	788	116	G
FN 3443-120-116-E0_****	88.7	120	144	138	0.349	0.118	113	250	831	116	G
FN 3443-160-118-E0_****	118	160	192	183	0.262	0.089	138	305	1199	118	H
FN 3443-200-118-E0_*****	147	200	240	229	0.210	0.071	152	336	1022	118	H
FN 3443-240-118-E0_*****	177	240	290	277	0.175	0.059	205	452	1292	118	H

* Filter rating which does not require forced cooling or fan module

** Filter rating which does not require RC damping module for rectifiers with EMI filter

*** Motor drive input current without harmonic filter

**** Typical losses @ 45°C, 380V, 60Hz and rated load power

***** In order to apply FN 3443 filters, motor drives have to be equipped with either DC-link choke or AC line choke. The minimum required inductance values are given in mH in the filter selection table. If neither DC-link choke nor AC line choke is present, or if the minimum mH rating is not fulfilled, FN 3443 filter must not be used. In this case, FN 3442 need to be chosen.

Filter power terminals

Terminal designation*	Screw thread	Flex wire AWG	Flex wire [mm ²]	Screw torque value		Max width** cable lug [mm]	Frame size
				[Nm]	[lbs-in]		
110	M3	14-22	0.4-2.5	0.5	4.4	7	A
112	M4	10-22	0.4-6	1.2	10.6	10	B, C
113	M6	6-18	0.75-16	3	26.6	15	D
115	M8	1/0-8	10-50	8	70.8	15	E, F
116	M8	3/0-8	10-95	8	70.8	17	G
118	M10	3/0-500 kcmil	95-240	10	88.5	35	H

* Recommended connector type: wire or cable lug for 110 to 113, only cable lug for 115 to 118

** To fulfill creepage/clearance acc. UL 61800-5-1 without additional protection (insulation). Creepage/clearance can vary depending on applicable standard and must be reviewed by customer. Creepage/clearance may be reduced when additional protection (insulation) is provided.

Filter signal and earth terminals

Terminal type	Screw thread	Screw torque value		Frame size
		[Nm]	[lbs-in]	
Signal	M3*	0.5	4.4	All
Earth (PE)	M5	2.2	19.5	A
Earth (PE)	M6	4	35.4	B, C
Earth (PE)	M8	9	79.7	D, E
Earth (PE)	M10	17	150.5	F, G, H

* Max width cable lug = 7 mm

Filter selection table @ 380 V / 60 Hz – IP 20 enclosure

Filter	Rated load power @ 380 V/60 Hz		Motor drive input current [Arms]***	Rated filter input current [Arms]	Min. required LDC [mH]*****	Min. required LAC [mH]*****	Weight		Typical losses [W]****	Terminal	Frame size
	[kW]	[HP]					[kg]	[lbs]			
FN 3443-1-110-E2_*****	0.9	1.2	1.4	1.37	21.5	11.61	7	14	41	110	A
FN 3443-2-110-E2_*****	1.7	2.4	2.9	2.74	18.2	6.145	8	18	53	110	A
FN 3443-4-112-E2_*****	2.9	4	4.8	4.52	10.7	3.602	11	23	88	112	B
FN 3443-6-112-E2_*****	4.5	6	7.2	6.85	7.04	2.374	13	29	101	112	B
FN 3443-8-112-E2_*****	5.9	8	9.6	9.20	5.25	1.771	16	35	123	112	C
FN 3443-12-112-E2_*****	8.7	12	14.4	13.7	3.56	1.201	18	39	183	112	C
FN 3443-16-113-E2_****	11.9	16	19.3	18.3	2.61	0.880	28	61	228	113	D
FN 3443-20-113-E2_****	15.0	20	24.0	23.0	2.06	0.696	30	66	277	113	D
FN 3443-24-113-E2_****	17.4	24	29.0	27.5	1.78	0.600	34	76	282	113	D
FN 3443-32-115-E2_****	23.8	32	38.5	36.8	1.30	0.434	44	97	370	115	E
FN 3443-40-115-E2_****	29.3	40	48.0	45.8	1.06	0.357	49	107	453	115	E
FN 3443-48-115-E2_****	35.6	48	58.0	55	0.869	0.293	55	121	476	115	E
FN 3443-60-115-E2_****	44.3	60	72.0	69	0.699	0.236	58	127	634	115	F
FN 3443-80-115-E2_****	59.4	80	97.0	92	0.521	0.176	76	168	779	115	F
FN 3443-100-116-E2_****	73.6	100	120	114	0.421	0.142	108	239	788	116	G
FN 3443-120-116-E2_****	88.7	120	144	138	0.349	0.118	125	275	831	116	G
FN 3443-160-118-E2_****	118	160	192	183	0.262	0.089	160	353	1199	118	H
FN 3443-200-118-E2_*****	147	200	240	229	0.210	0.071	173	382	1022	118	H
FN 3443-240-118-E2_*****	177	240	290	277	0.175	0.059	226	497	1292	118	H

* Filter rating which does not require forced cooling or fan module

** Filter rating which does not require RC damping module for rectifiers with EMI filter

*** Motor drive input current without harmonic filter

**** Typical losses @ 45°C, 380V, 60Hz and rated load power

***** In order to apply FN 3443 filters, motor drives have to be equipped with either DC-link choke or AC line choke. The minimum required inductance values are given in mH in the filter selection table. If neither DC-link choke nor AC line choke is present, or if the minimum mH rating is not fulfilled, FN 3443 filter must not be used. In this case, FN 3442 need to be chosen.

Filter power terminals

Terminal designation*	Screw thread	Flex wire AWG	Flex wire [mm ²]	Screw torque value		Max width** cable lug [mm]	Frame size
				[Nm]	[lbs-in]		
110	M3	14-22	0.4-2.5	0.5	4.4	7	A
112	M4	10-22	0.4-6	1.2	10.6	10	B, C
113	M6	6-18	0.75-16	3	26.6	15	D
115	M8	1/0-8	10-50	8	70.8	15	E, F
116	M8	3/0-8	10-95	8	70.8	17	G
118	M10	3/0-500 kcmil	95-240	10	88.5	35	H

* Recommended connector type: wire or cable lug for 110 to 113, only cable lug for 115 to 118

** To fulfill creepage/clearance acc. UL 61800-5-1 without additional protection (insulation). Creepage/clearance can vary depending on applicable standard and must be reviewed by customer. Creepage/clearance may be reduced when additional protection (insulation) is provided.

Filter signal and earth terminals

Terminal type	Screw thread	Screw torque value		Frame size
		[Nm]	[lbs-in]	
Signal	M3*	0.5	4.4	All
Earth (PE)	M5	2.2	19.5	A
Earth (PE)	M6	4	35.4	B, C
Earth (PE)	M8	9	79.7	D, E
Earth (PE)	M10	17	150.5	F, G, H

* Max width cable lug = 7 mm

Product selector

FN 34nn-xxx-yyy-

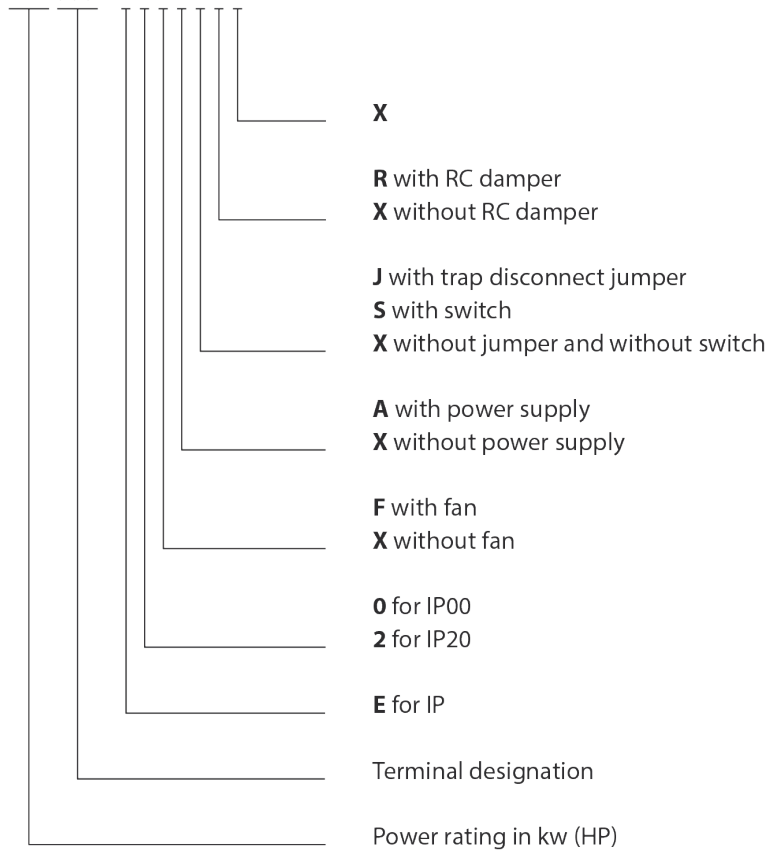

Filter configurations

E0XXXXX

- For rectifiers with DC-link choke

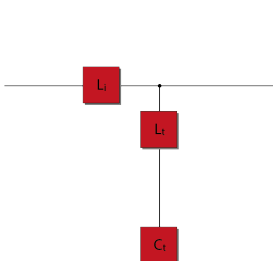

E0FAXRX

- For rectifiers with DC-link choke and with EMI filter
 - Filters contain fan, aux. power supply and RC damper module

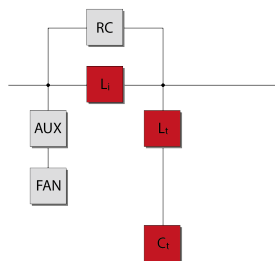

E0FAJRX and E2FAJRX

- For rectifiers with DC-link choke and with EMI filter
 - Filters contain fan, aux. power supply, RC damper module and trap disconnect jumper

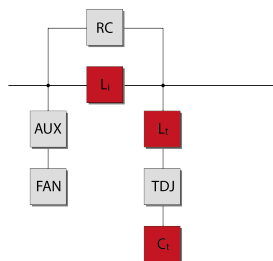

Mechanical data of IP 00 enclosure

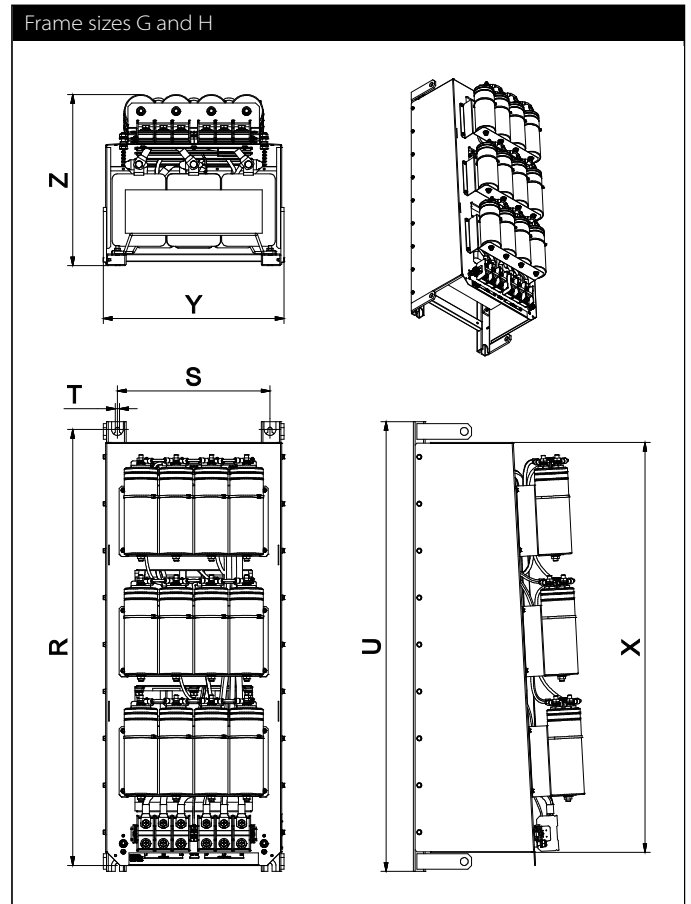
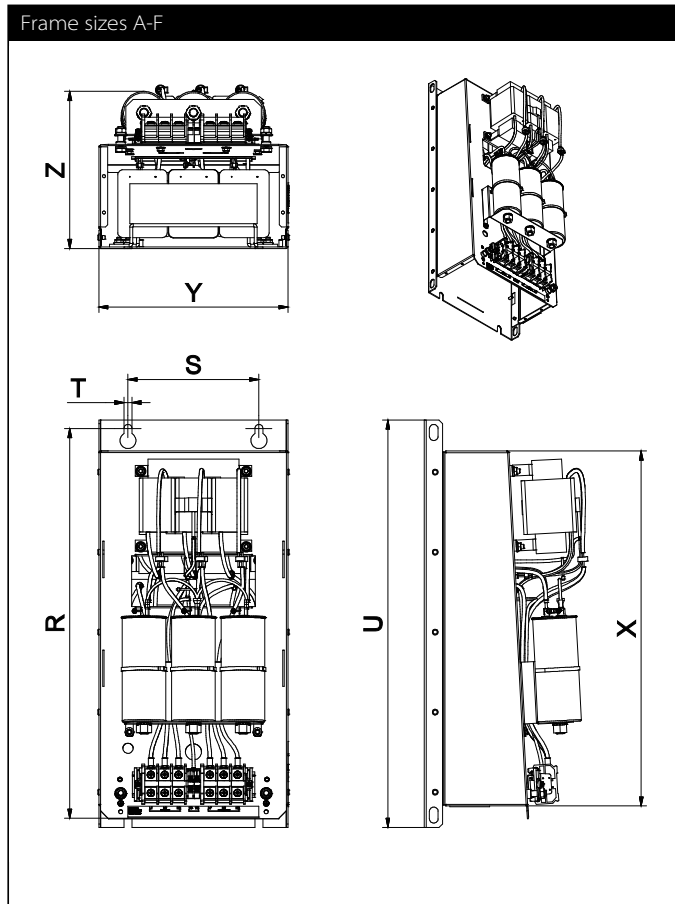

Dimensions

Frame	Dimensions in [mm]								Dimensions in [in]							
	Drill pattern			Base	Volume				Drill pattern			Base	Volume			
	R	S	T	U	X	Y	Z	R	S	T	U	X	Y	Z		
A	340	120	7	360	302	160	185	13.4	4.7	0.3	14.2	11.9	6.3	7.3		
B	405	120	7	425	370	180	206	15.9	4.7	0.3	16.7	14.6	7.1	8.1		
C	460	150	7	483	430	210	221	18.1	5.9	0.3	19.0	16.9	8.3	8.7		
D	540	180	11	560	491	260	252	21.3	7.1	0.4	22.0	19.3	10.2	9.9		
E	680	220	11	705	635	290	319	26.8	8.7	0.4	27.8	25.0	11.4	12.6		
F	730	250	11	752	684	340	343	28.7	9.8	0.4	29.6	26.9	13.4	13.5		
G	920	280	11	960	863	353	386	36.2	11.0	0.4	37.8	34.0	13.9	15.2		
H	1115	390	11	1150	1053	462	456	43.9	15.4	0.4	45.3	41.5	18.2	18.0		

Inlet air flow required for cooling

Frame size	Min air volume*	
	[m³/h]	CFM [ft³/min]
A, B, C	0	0
D	128	75
E	204	120
F, G	408	240
H	612	360

* External air flow required for filter configurations without embedded ventilation

Mechanical data of IP 20 enclosure

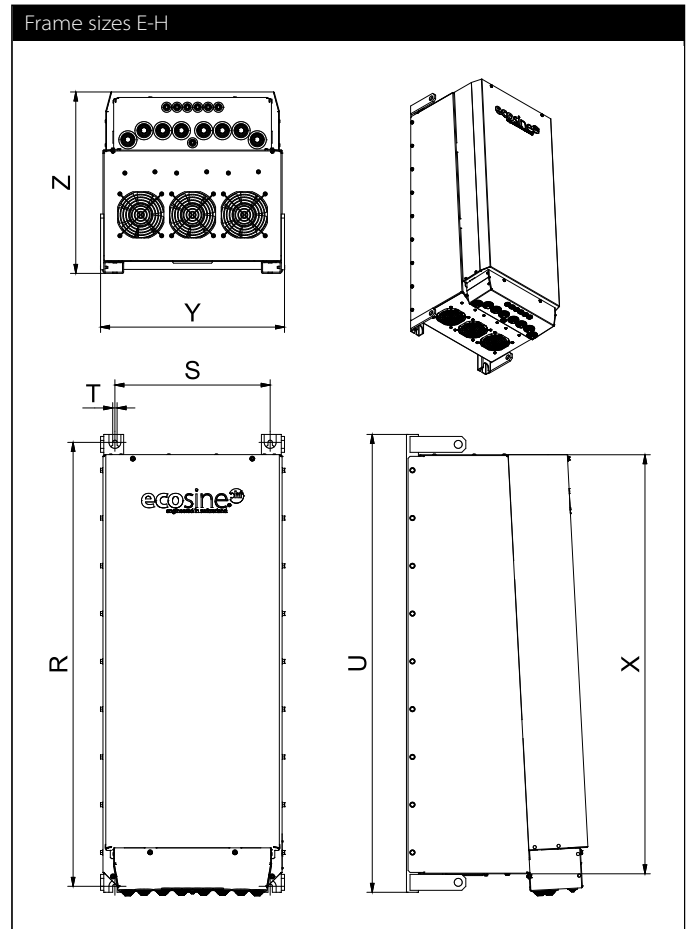
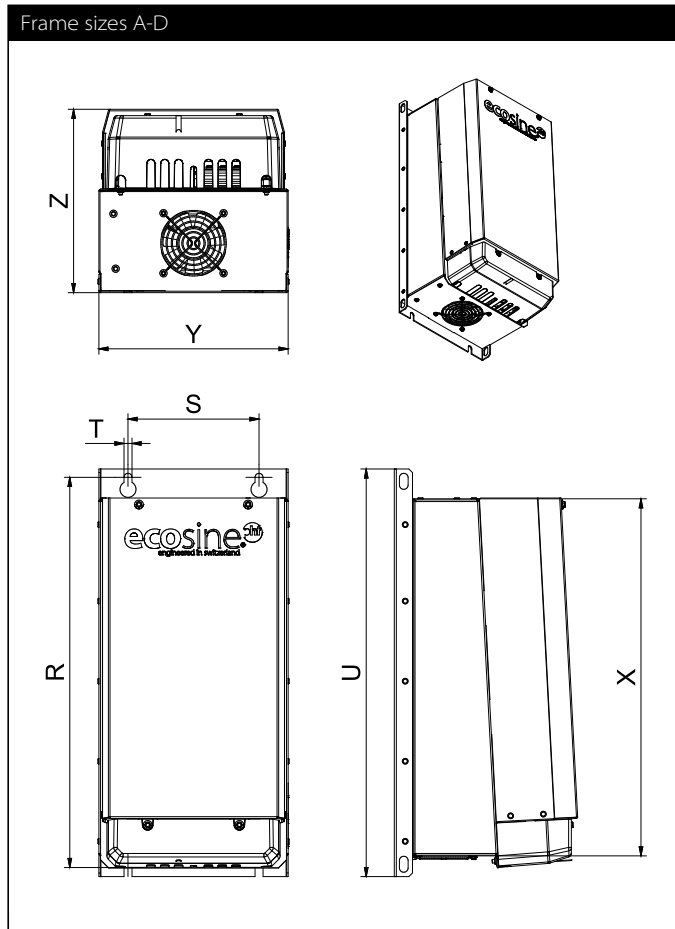

Dimensions

Frame	Dimensions in [mm]							Dimensions in [in]							
	R	Drill pattern			Base	Volume			R	Drill pattern			Base	Volume	
		S	T	U	X	Y	Z		S	T	U	X	Y	Z	
A	340	120	7	360	302	160	185	13.4	4.7	0.3	14.2	11.9	6.3	7.3	
B	405	120	7	425	370	180	206	15.9	4.7	0.3	16.7	14.6	7.1	8.1	
C	460	150	7	483	430	210	221	18.1	5.9	0.3	19.0	16.9	8.3	8.7	
D	540	180	11	560	491	260	252	21.3	7.1	0.4	22.0	19.3	10.2	9.9	
E	680	220	11	705	635	290	319	26.8	8.7	0.4	27.8	25.0	11.4	12.6	
F	730	250	11	752	684	340	343	28.7	9.8	0.4	29.6	26.9	13.4	13.5	
G	920	280	11	960	863	353	386	36.2	11.0	0.4	37.8	34.0	13.9	15.2	
H	1115	390	11	1150	1053	462	456	43.9	15.4	0.4	45.3	41.5	18.2	18.0	

Inlet air flow required for cooling

Frame size	Min air volume*	
	[m ³ /h]	CFM [ft ³ /min]
A, B, C	0	0
D	128	75
E	204	120
F, G	408	240
H	612	360

* External air flow required for filter configurations without embedded ventilation