

# Ecosine evo, 480 VAC 50 Hz Passive Harmonic Filters for 6-pulse rectifier with 8% DC-Link choke



- The industry standard for 6-pulse rectifier and motor drives
- Filters for diode rectifier with DC-link choke
- Best-in-class partial load performance
- Most compact design
- Plug and play, ready to use



## Approvals & Compliances



(depending on filter configuration)

## Features and benefits

Schaffner ecosine harmonic filters represent an economical solution to the challenge of load-applied harmonics mitigation in three-phase power systems. With a plug-and-play approach and more compact dimensions than comparable products, they can be quickly installed and easily commissioned. They increase the reliability and service life of electric installations, help utilize electric system capacity better, and are the key to meet Power Quality standards such as IEEE 519. Ecosine filters reshape your distorted current back to the desired sinusoidal waveform. Schaffner ecosine filters can be applied to virtually any kind of power electronics with front-end six-pulse rectifiers, 3-phase diode or thyristor bridges, where harmonic current distortion needs to be reduced to defined limits.

## Typical applications

- Equipment with front-end six-pulse rectifier
- Motor drives
- Factory automation equipment
- Water/wastewater treatment facilities
- Fan and pump applications
- HVAC installations
- Mission-critical processes
- DC fast chargers

## Technical specifications

<b>Nominal operating voltage</b>	3 x 440 VAC to 500 VAC ±10%
<b>Operating frequency</b>	50 Hz ±1 Hz
<b>Nominal motor drive input power rating</b>	1.1 to 315 kW
<b>Total harmonic current distortion THDi*</b>	≤5% at rated power
<b>Efficiency</b>	>98% for rated voltage and power
<b>Overload capability</b>	1.6x rated current for 1 minute, once per hour
<b>SCCR**</b>	100 kA
<b>High potential test voltage</b>	P → E 2160 VAC (1 s)
<b>Oversvoltage category</b>	OV III (IEC 60664-1 / UL 61800-5-1)
<b>Earthing System</b>	TN, TT, IT
<b>Protection category</b>	IP 00, IP 20
<b>Cooling</b>	Internal fan cooling or external cooling***
<b>Ambient temperature range</b>	-25°C to +45°C fully operational +45°C to +70°C derated operation**** +45°C to +70°C derated operation***
<b>Design corresponding to</b>	Filter: UL 61800-5-1, EN 61800-5-1 Chokes: EN 61558-2-20 or EN 60076-6
<b>Flammability corresponding to</b>	UL 94 V-2
<b>MTBF @ 45°C/480 V (Mil-HB-217F)</b>	>200,000 hours

\* System requirements: THDv <2%, line voltage unbalance <1%  
 Note: performance specifications in this brochure refer to six-pulse diode rectifiers with 8% DC-link choke. THDi ~5% at rated power for filter <6 kW/HP  
 \*\* External UL-rated fuses required. Please consult the user manual.  
 \*\*\* Please check the inlet air flow required for cooling table further in this document and the user manual.  
 \*\*\*\*  $I_{derated} = I_{nominal} \cdot \sqrt{\frac{(T_{max} - T_{amb})}{(T_{max} - T_{nominal})}} = I_{nominal} \cdot \sqrt{\frac{(70^\circ\text{C} - T_{amb})}{25^\circ\text{C}}}$

## Typical electrical schematic

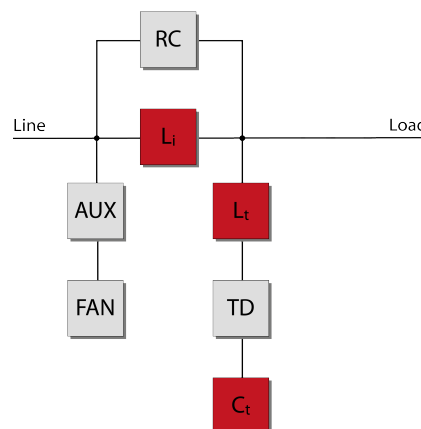

(all configurable optional functionalities shown)

## Filter selection table – IP 00 enclosure

Filter	Rated load power @ 480 VAC/50 Hz [kW]	Motor drive input current [Arms]***	Rated filter input current [Arms]	Min. required LDC [mH]****	Min. required LAC [mH]****	Weight [kg]	Typical losses [W]****	Terminal	Frame size
FN3451-1-110-E0__*	1.1	1.4	1.3	53.9	16.70	5	40	110	A
FN3451-2-110-E0__*	2.2	2.8	2.7	26.9	7.85	7	61	110	A
FN3451-4-112-E0__*	4.0	5.1	4.9	14.8	4.47	10	104	112	B
FN3451-6-112-E0__*	5.5	7.1	6.7	10.8	3.48	12	104	112	B
FN3451-8-112-E0__*	7.5	9.6	9.2	7.90	2.55	15	143	112	C
FN3451-11-112-E0__*	11	14.1	13.4	5.39	1.82	17	193	112	C
FN3451-15-113-E0__	15	19.3	18.3	3.95	1.26	24	233	113	D
FN3451-19-113-E0__	19	24.4	23.0	3.12	1.02	27	292	113	D
FN3451-22-113-E0__	22	28.0	27.0	2.69	0.88	31	274	113	D
FN3451-30-115-E0__	30	38.5	36.6	1.98	0.64	38	355	115	E
FN3451-37-115-E0__	37	47.5	45.5	1.60	0.527	43	426	115	E
FN3451-45-115-E0__	45	58	55	1.32	0.451	49	458	115	E
FN3451-55-115-E0__	55	71	67	1.08	0.357	54	611	115	F
FN3451-75-115-E0__	75	97	92	0.790	0.265	70	781	115	F
FN3451-90-116-E0__	90	116	110	0.660	0.218	100	740	116	G
FN3451-110-116-E0__	110	142	135	0.540	0.176	108	799	116	G
FN3451-132-118-E0__	132	170	162	0.450	0.149	130	1063	118	H
FN3451-160-118-E0__**	160	207	197	0.370	0.118	149	1039	118	H
FN3451-200-118-E0__**	200	259	246	0.300	0.094	183	1232	118	H
FN3451-250-118-E0__**	250	324	308	0.240	0.073	208	1262	118	H
FN3451-315-119-E0XXSXX	315	410	392	0.188	0.059	252	1553	119	J

\* Filter rating which does not require forced cooling or fan module

\*\* Filter rating which does not require RC damping module for rectifiers with EMI filter

\*\*\* Motor drive input current without harmonic filter

\*\*\*\* Typical losses @ 45°C, 480V, 50Hz and rated load power

\*\*\*\*\* **In order to apply FN 3451 filters, motor drives have to be equipped with either DC-link choke or AC line choke. The minimum required inductance values are given in mH in the filter selection table. If neither DC-link choke nor AC line choke is present, or if the minimum mH rating is not fulfilled, FN 3451 filter must not be used. In this case, FN 3450 need to be chosen.**

## Filter power terminals

Terminal designation*	Screw thread	Flex wire AWG	Flex wire [mm <sup>2</sup> ]	Screw torque value [Nm]	Max width** cable lug [mm]	Frame size
110	M3	14-22	0.4-2.5	0.5	7	A
112	M4	10-22	0.4-6	1.2	10	B, C
113	M6	6-18	0.75-16	3	15	D
115	M8	1/0-8	10-50	8	15	E, F
116	M8	3/0-8	10-95	8	17	G
118	M10	3/0-500 kcmil	95-240	10	35	H
119	M16	350-750 kcmil	185-400	10	48	J

\* Recommended connector type: wire or cable lug for 110 to 113, only cable lug for 115 to 119

\*\* To fulfill creepage/clearance acc. UL 61800-5-1 without additional protection (insulation). Creepage/clearance can vary depending on applicable standard and must be reviewed by customer. Creepage/clearance may be reduced when additional protection (insulation) is provided.

## Filter signal and earth terminals

Terminal type	Screw thread	Screw torque value [Nm]	Frame size
Signal	M3*	0.5	All
Earth (PE)	M5	2.2	A
Earth (PE)	M6	4	B, C
Earth (PE)	M8	9	D, E
Earth (PE)	M10	17	F, G, H
Earth (PE)	M12	25	J

\* Max width cable lug = 7 mm

## Filter selection table – IP 20 enclosure

Filter	Rated load power @ 400 V/50 Hz [kW]	Motor drive input current [Arms]**	Rated filter input current [Arms]	Min. required LDC [mH]*****	Min. required LAC [mH]*****	Weight [kg]	Typical losses [W]****	Terminal	Frame size
FN3451-1-110-E2_*	1.1	1.4	1.3	53.9	16.7	6	40	110	A
FN3451-2-110-E2_*	2.2	2.8	2.7	26.9	7.85	8	61	110	A
FN3451-4-112-E2_*	4.0	5.1	4.9	14.8	4.47	11	104	112	B
FN3451-6-112-E2_*	5.5	7.1	6.7	10.8	3.48	13	104	112	B
FN3451-8-112-E2_*	7.5	9.6	9.2	7.90	2.55	16	143	112	C
fn3451-11-112-E2_	11	14.1	13.4	5.39	1.82	19	193	112	C
FN3451-15-113-E2_	15	19.3	18.3	3.95	1.26	28	233	113	D
FN3451-19-113-E2_	19	24.4	23.0	3.12	1.02	30	292	113	D
FN3451-22-113-E2_	22	28.0	27.0	2.69	0.880	34	274	113	D
FN3451-30-115-E2_	30	38.5	36.6	1.98	0.640	44	355	115	E
FN3451-37-115-E2_	37	47.5	45.0	1.60	0.527	49	426	115	E
FN3451-45-115-E2_	45	58	55	1.32	0.451	55	458	115	E
FN3451-55-115-E2_	55	71	67	1.08	0.357	62	611	115	F
FN3451-75-115-E2_	75	97	92	0.790	0.265	77	781	115	F
FN3451-90-116-E2_	90	116	110	0.660	0.218	109	740	116	G
FN3451-110-116-E2_	110	142	135	0.540	0.176	117	799	116	G
FN3451-132-118-E2_	132	170	162	0.450	0.149	147	1063	118	H
FN3451-160-118-E2_**	160	207	197	0.370	0.118	166	1039	118	H
FN3451-200-118-E2_**	200	259	246	0.300	0.094	200	1232	118	H
FN3451-250-118-E2_**	250	324	308	0.240	0.073	225	1262	118	H
FN3451-315-119-E2FASXX	315	410	392	0.188	0.059	278	1553	119	J

\* Filter rating which does not require forced cooling or fan module

\*\* Filter rating which does not require RC damping module for rectifiers with EMI filter

\*\*\* Motor drive input current without harmonic filter

\*\*\*\* Typical losses @ 45°C, 400V, 50Hz and rated load power

\*\*\*\*\* **In order to apply FN 3451 filters, motor drives have to be equipped with either DC-link choke or AC line choke. The minimum required inductance values are given in mH in the filter selection table. If neither DC-link choke nor AC line choke is present, or if the minimum mH rating is not fulfilled, FN 3451 filter must not be used. In this case, FN 3450 need to be chosen.**

## Filter power terminals

Terminal designation*	Screw thread	Flex wire AWG	Flex wire [mm <sup>2</sup> ]	Screw torque value [Nm]	Max width** cable lug [mm]	Frame size
110	M3	14-22	0.4-2.5	0.5	7	A
112	M4	10-22	0.4-6	1.2	10	B, C
113	M6	6-18	0.75-16	3	15	D
115	M8	1/0-8	10-50	8	15	E, F
116	M8	3/0-8	10-95	8	17	G
118	M10	3/0-500 kcmil	95-240	10	35	H
119	M16	350-750 kcmil	185-400	10	48	J

\* Recommended connector type: wire or cable lug for 110 to 113, only cable lug for 115 to 119

\*\* To fulfill creepage/clearance acc. UL 61800-5-1 without additional protection (insulation). Creepage/clearance can vary depending on applicable standard and must be reviewed by customer. Creepage/clearance may be reduced when additional protection (insulation) is provided.

## Filter signal and earth terminals

Terminal type	Screw thread	Screw torque value [Nm]	Frame size
Signal	M3*	0.5	All
Earth (PE)	M5	2.2	A
Earth (PE)	M6	4	B, C
Earth (PE)	M8	9	D, E
Earth (PE)	M10	17	F, G, H
Earth (PE)	M12	25	J

\* Max width cable lug = 7 mm

Product selector

FN 34nn-xxx-yyy-

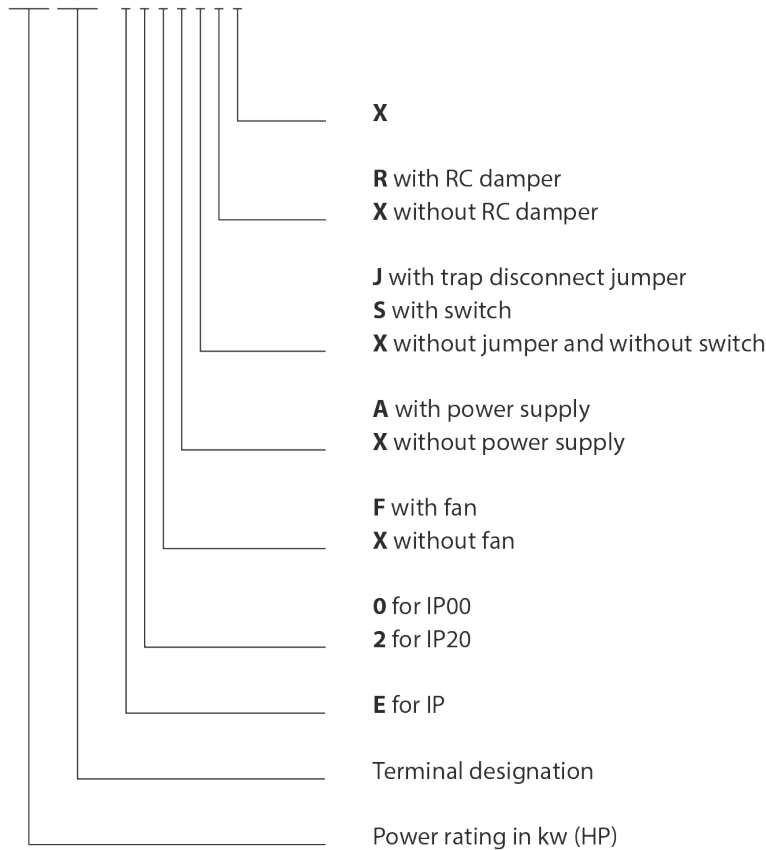
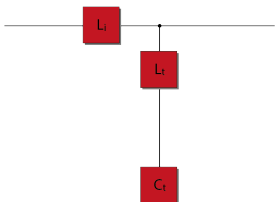

**Table 1: Filter configurations if external air flow is available for cooling**

(Filters do **not** contain fan and do **not** contain aux. power supply)

**E0XXXXX**

- For rectifiers with DC-link choke



**E0XXJXX**

- For rectifiers with DC-link choke

- Filters contain trap disconnect jumper

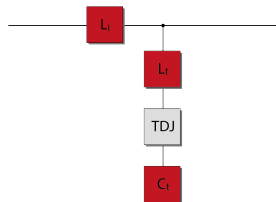

**E0XXRX**

- For rectifiers with DC-link choke and with EMI filter

- Filters contain RC damper module

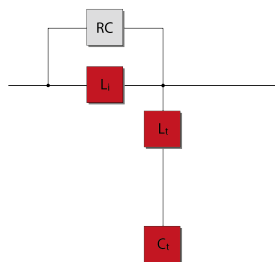

**E0XXJRX**

- For rectifiers with DC-link choke and with EMI filter

- Filters contain RC damper module and trap disconnect jumper

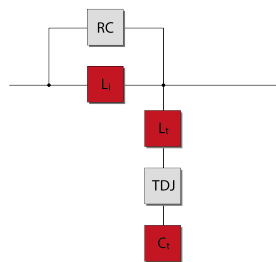

### Table 2: Filter configurations with embedded ventilation

(Filters contain fan and aux. power supply)

#### E0FAXXX and E2FAXXX

- For rectifiers with DC-link choke
- Filters contain fan and aux. power supply

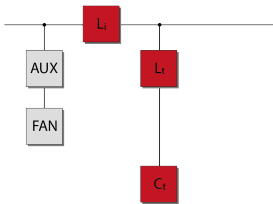

#### E0FAJXX and E2FAJXX

- For rectifiers with DC-link choke
- Filters contain fan, aux. power supply and trap disconnect jumper

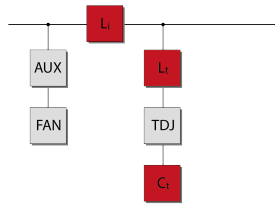

#### E0FAXRX and E2FAXRX

- For rectifiers with DC-link choke and with EMI filter
- Filters contain fan, aux. power supply and RC damper module

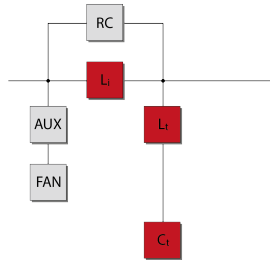

#### E0FAJRX and E2FAJRX

- For rectifiers with DC-link choke and with EMI filter
- Filters contain fan, aux. power supply, RC damper module and trap disconnect jumper

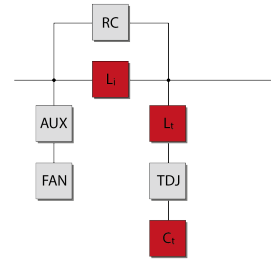

### Table 3: Filter configurations if external aux. power supply for the fan is available

(Filters contain fan but do not contain aux. power supply, user should provide aux. power supply to the fan)

#### E0FXXXX and E2FXXXX

- For rectifiers with DC-link choke
- Filters contain fan

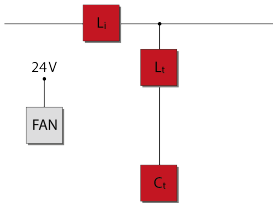

#### E0FXJXX and E2FXJXX

- For rectifiers with DC-link choke
- Filters contain fan and trap disconnect jumper

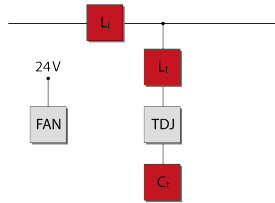

#### E0FXRX and E2FXRX

- For rectifiers with DC-link choke and with EMI filter
- Filters contain fan and RC damper module

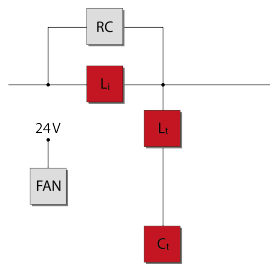

#### E0FXJRX and E2FXJRX

- For rectifiers with DC-link choke and with EMI filter
- Filters contain fan, RC damper module and trap disconnect jumper

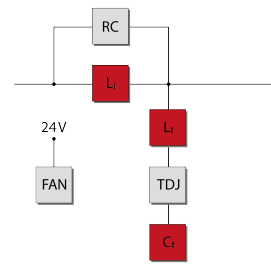

### Table 4: 315 kW Filter configuration

#### E0XXSXX

- For rectifiers with DC-link choke
- Filters contain circuit breaker

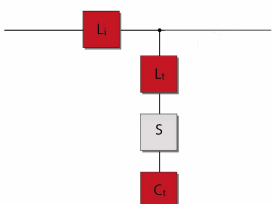

#### E2FASXX

- For rectifiers with DC-link choke
- Filters contain fan aux. power supply and circuit breaker

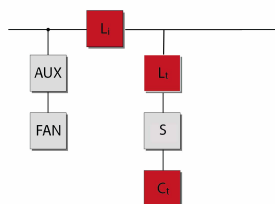

### Mechanical data of IP 00 enclosure

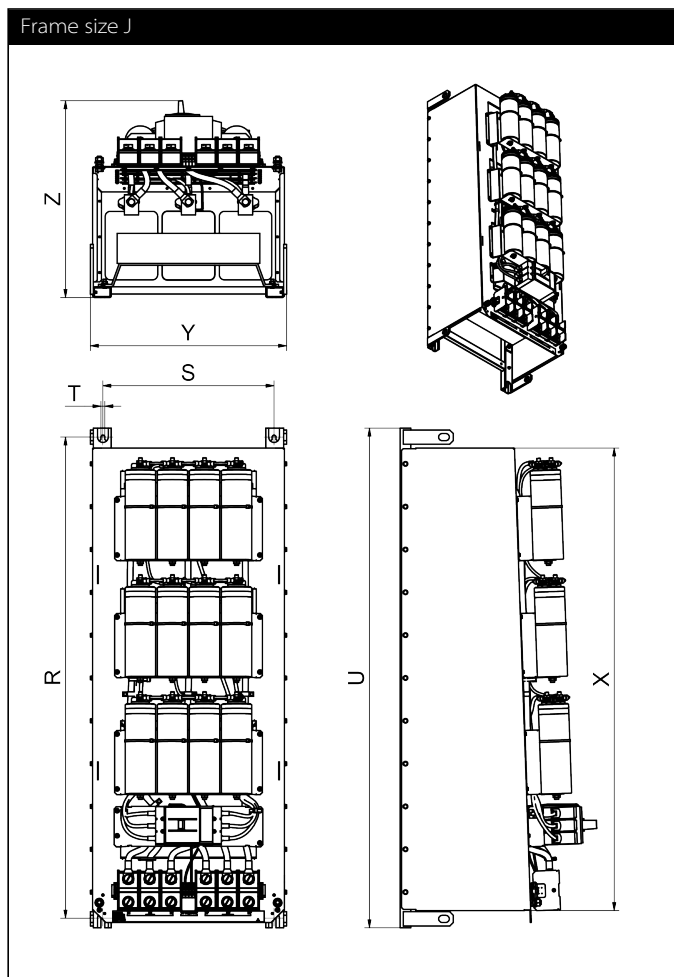
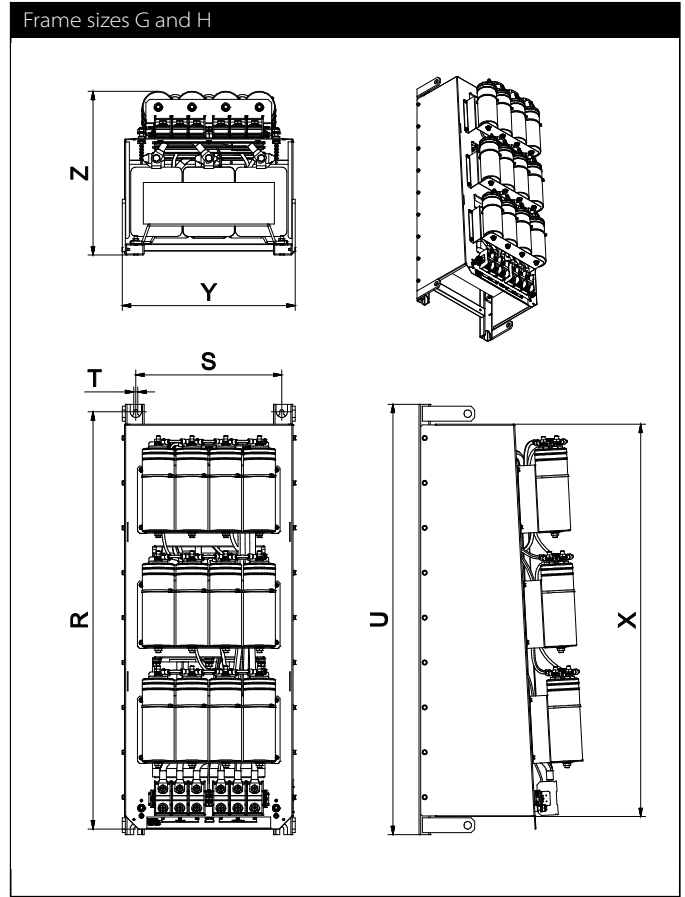
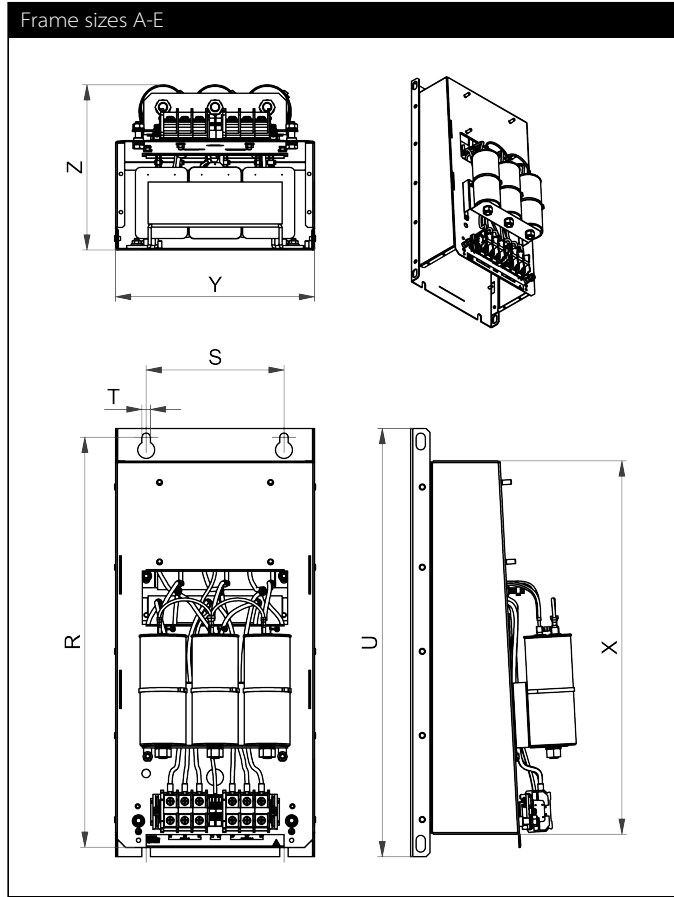

## Dimensions

Frame	Drill pattern [mm]			Base [mm]			Volume [mm]
	R	S	T	U	X	Y	
<b>A</b>	340	120	7	360	302	160	185
<b>B</b>	405	120	7	425	370	180	206
<b>C</b>	460	150	7	483	430	210	221
<b>D</b>	540	180	11	560	491	260	252
<b>E</b>	680	220	11	705	635	290	319
<b>F</b>	730	250	11	752	684	340	343
<b>G</b>	920	280	11	960	863	353	386
<b>H</b>	1115	390	11	1150	1053	462	456
<b>J</b>	1348	480	11	1400	1300	550	555

## Inlet air flow required for cooling

Frame size	Min air volume* [m <sup>3</sup> /h]
<b>A, B, C</b>	0
<b>D</b>	128
<b>E</b>	204
<b>G</b>	408
<b>H</b>	612
<b>J</b>	816

\* External air flow required for filter configurations without embedded ventilation

### Mechanical data of IP 20 enclosure

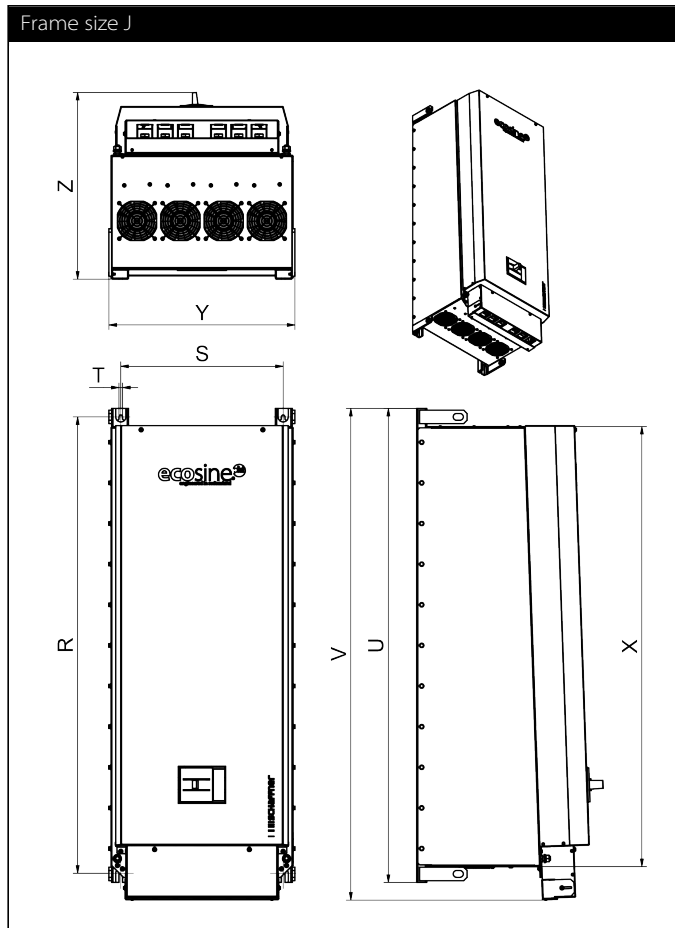
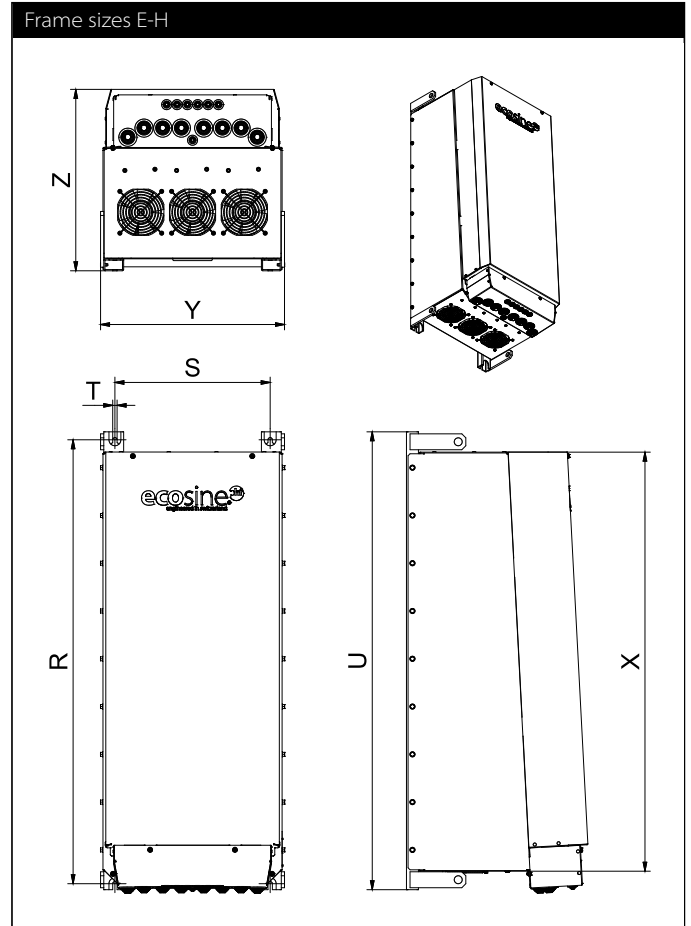
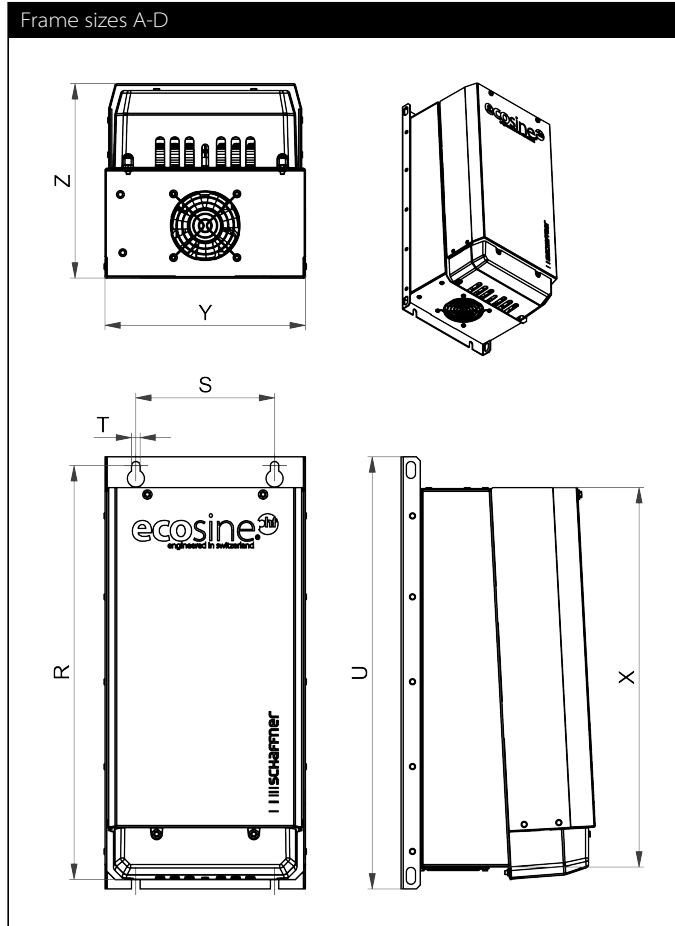



## Dimensions

Frame	Drill pattern [mm]			Base [mm]			Volume [mm]		
	R	S	T	U	X	Y	Z	V	
<b>A</b>	340	120	7	360	302	160	185		
<b>B</b>	405	120	7	425	370	180	206		
<b>C</b>	460	150	7	483	430	210	221		
<b>D</b>	540	180	11	560	491	260	252		
<b>E</b>	680	220	11	705	635	290	319		
<b>F</b>	730	250	11	752	684	340	343		
<b>G</b>	920	280	11	960	863	353	386		
<b>H</b>	1115	390	11	1150	1053	462	456		
<b>J</b>	1348	480	11	1400	1300	550	555	1455	

## Inlet air flow required for cooling

Frame size	Min air volume* [m <sup>3</sup> /h]
<b>A, B, C</b>	0
<b>D</b>	128
<b>E</b>	204
<b>G</b>	408
<b>H</b>	612
<b>J</b>	816

\* External air flow required for filter configurations without embedded ventilation