

Ecosine evo, 480 VAC 60 Hz Passive Harmonic Filters for 6-pulse rectifier with 8% DC-Link choke

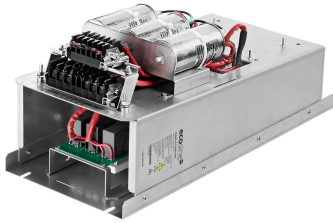

- The industry standard for 6-pulse rectifier and motor drives
- Filters for diode rectifier with DC-link choke
- Best-in-class partial load performance
- Most compact design
- Plug and play, ready to use



Approvals & Compliances



(depending on filter configuration)

Features and benefits

Schaffner ecosine harmonic filters represent an economical solution to the challenge of load-applied harmonics mitigation in three-phase power systems. With a plug-and-play approach and more compact dimensions than comparable products, they can be quickly installed and easily commissioned. They increase the reliability and service life of electric installations, help utilize electric system capacity better, and are the key to meet Power Quality standards such as IEEE 519. Ecosine filters reshape your distorted current back to the desired sinusoidal waveform. Schaffner ecosine filters can be applied to virtually any kind of power electronics with front-end six-pulse rectifiers, 3-phase diode or thyristor bridges, where harmonic current distortion needs to be reduced to defined limits.

Typical applications

- Equipment with front-end six-pulse rectifier
- Motor drives
- Factory automation equipment
- Water/wastewater treatment facilities
- Fan and pump applications
- HVAC installations
- Mission-critical processes
- DC fast chargers

Technical specifications

Nominal operating voltage	3 x 440 VAC to 480 VAC ±10%
Operating frequency	60 Hz ±1 Hz
Nominal motor drive input power rating	1.5 to 300 HP
Total harmonic current distortion THDi*	<5% at rated power
Efficiency	>98% for rated voltage and power
Overload capability	1.6x rated current for 1 minute, once per hour
SCCR**	100 kA
High potential test voltage	P → E 2160 VAC (1 s)
Oversvoltage category	OV III (IEC 60664-1 / UL 61800-5-1)
Earthing System	TN, TT, IT
Protection category	IP 00, IP 20
Cooling	Internal fan cooling or external cooling***
Ambient temperature range	-25°C to +45°C fully operational +45°C to +70°C derated operation**** +45°C to +70°C derated operation***
Design corresponding to	Filter: UL 61800-5-1, EN 61800-5-1 Chokes: EN 61558-2-20 or EN 60076-6
Flammability corresponding to	UL 94 V-2
MTBF @ 45°C/480 V (Mil-HB-217F)	>200,000 hours

* System requirements: THDv <2%, line voltage unbalance <1%
Note: performance specifications in this brochure refer to six-pulse diode rectifiers with 8% DC-link choke. THDi ~5% at rated power for filter <6 kW/HP
** External UL-rated fuses required. Please consult the user manual.
*** Please check the inlet air flow required for cooling table further in this document and the user manual.
**** $I_{derated} = I_{nominal} \cdot \sqrt{\frac{(T_{max} - T_{amb})}{(T_{max} - T_{nominal})}} = I_{nom} \cdot \sqrt{\frac{(70^\circ\text{C} - T_{amb})}{25^\circ\text{C}}}$

Typical electrical schematic

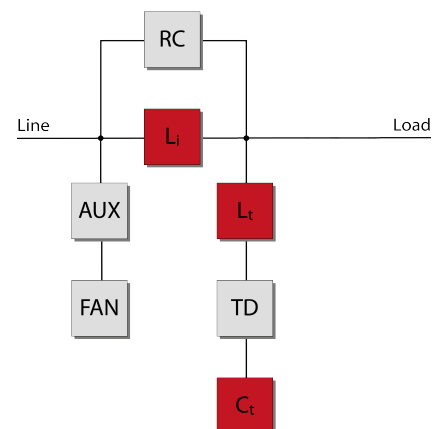

(all configurable optional functionalities shown)

Filter selection table – IP 00 enclosure

Filter	Rated load power		Motor drive input current [Arms]***	Rated filter input current [Arms]	Min. required LDC [mH]****	Min. required LAC [mH]****	Weight		Typical losses [W]****	Terminal	Frame size
	@ 480 V/60 Hz						[kg]	[lbs]			
	[kW]	[HP]									
FN 3453-1-110-E0_*****	1.1	1.5	1.44	1.37	44.1	14.0	5	11	41	110	A
FN 3453-3-110-E0_*****	2.2	3	2.87	2.74	22.1	6.89	7	15	53	110	A
FN 3453-5-112-E0_*****	3.7	5	4.75	4.52	13.4	4.47	9	20	88	112	B
FN 3453-8-112-E0_*****	5.6	7.5	7.18	6.85	8.82	2.81	12	26	101	112	B
FN 3453-10-112-E0_*****	7.5	10	9.60	9.20	6.59	2.14	13	29	123	112	C
FN 3453-15-112-E0_*****	11	15	14.4	13.7	4.41	1.46	16	35	183	112	C
FN 3453-20-113-E0_****	15	20	19.3	18.3	3.29	1.08	23	51	228	113	D
FN 3453-25-113-E0_****	19	25	24.0	23.0	2.64	0.858	26	57	277	113	D
FN 3453-30-113-E0_****	22	30	29.0	27.5	2.20	0.724	30	66	282	113	D
FN 3453-40-115-E0_****	30	40	38.5	36.8	1.67	0.531	37	82	370	115	E
FN 3453-50-115-E0_****	37	50	48.0	45.8	1.32	0.433	42	93	453	115	E
FN 3453-60-115-E0_****	45	60	58	55	1.10	0.361	48	106	476	115	E
FN 3453-75-115-E0_****	56	75	72	69	0.882	0.297	49	108	634	115	F
FN 3453-100-115-E0_****	75	100	97	92	0.658	0.214	68	150	779	115	F
FN 3453-125-116-E0_****	93	125	120	114	0.531	0.178	97	214	788	116	G
FN 3453-150-116-E0_****	112	150	144	138	0.441	0.147	113	249	831	116	G
FN 3453-200-118-E0_****	149	200	192	183	0.331	0.106	138	304	1199	118	H
FN 3453-250-118-E0_*****	186	250	241	229	0.266	0.085	152	335	1022	118	H
FN 3453-300-118-E0_*****	224	300	290	277	0.220	0.073	205	452	1292	118	H

* Filter rating which does not require forced cooling or fan module

** Filter rating which does not require RC damping module for rectifiers with EMI filter

*** Motor drive input current without harmonic filter

**** Typical losses @ 45°C, 480V, 60Hz and rated load power

***** In order to apply FN 3453 filters, motor drives have to be equipped with either DC-link choke or AC line choke. The minimum required inductance values are given in mH in the filter selection table. If neither DC-link choke nor AC line choke is present, or if the minimum mH rating is not fulfilled, FN 3453 filter must not be used. In this case, FN 3452 need to be chosen.

Filter power terminals

Terminal designation*	Screw thread	Flex wire AWG	Flex wire		Screw torque value		Max width** cable lug [mm]	Frame size
			[mm ²]	[Nm]	[lbs-in]			
110	M3	14-22	0.4-2.5	0.5	4.4	7	A	
112	M4	10-22	0.4-6	1.2	10.6	10	B, C	
113	M6	6-18	0.75-16	3	26.6	15	D	
115	M8	1/0-8	10-50	8	70.8	15	E, F	
116	M8	3/0-8	10-95	8	70.8	17	G	
118	M10	3/0-500 kcmil	95-240	10	88.5	35	H	

* Recommended connector type: wire or cable lug for 110 to 113, only cable lug for 115 to 118

** To fulfill creepage/clearance acc. UL 61800-5-1 without additional protection (insulation). Creepage/clearance can vary depending on applicable standard and must be reviewed by customer. Creepage/clearance may be reduced when additional protection (insulation) is provided.

Filter signal and earth terminals

Terminal type	Screw thread	Screw torque value		Frame size
		[Nm]	[lbs-in]	
Signal	M3*	0.5	4.4	All
Earth (PE)	M5	2.2	19.5	A
Earth (PE)	M6	4	35.4	B, C
Earth (PE)	M8	9	79.7	D, E
Earth (PE)	M10	17	150.5	F, G, H

* Max width cable lug = 7 mm

Filter selection table – IP 20 enclosure

Filter	Rated load power		Motor drive input current [Arms]***	Rated filter input current [Arms]	Min. required LDC [mH]****	Min. required LAC [mH]****	Weight		Typical losses [W]****	Terminal	Frame size
	@ 480 V/60 Hz						[kg]	[lbs]			
	[kW]	[HP]									
FN 3453-1-110-E2_*****	1.1	1.5	1.44	1.37	44.1	14.0	6	13	41	110	A
FN 3453-3-110-E2_*****	2.2	3.0	2.87	2.74	22.1	6.89	8	18	53	110	A
FN 3453-5-112-E2_*****	3.7	5.0	4.75	4.52	13.4	4.47	10	22	88	112	B
FN 3453-8-112-E2_*****	5.6	7.5	7.18	6.85	8.82	2.81	13	29	101	112	B
FN 3453-10-112-E2_*****	7.5	10	9.60	9.20	6.59	2.14	15	33	123	112	C
FN 3453-15-112-E2_*****	11	15	14.4	13.7	4.41	1.46	17	37	183	112	C
FN 3453-20-113-E2_****	15	20	19.3	18.3	3.29	1.08	27	60	228	113	D
FN 3453-25-113-E2_****	19	25	24.0	23.0	2.64	0.858	29	64	277	113	D
FN 3453-30-113-E2_****	22	30	29.0	27.5	2.20	0.724	34	75	282	113	D
FN 3453-40-115-E2_****	30	40	38.5	36.8	1.65	0.531	43	95	370	115	E
FN 3453-50-115-E2_****	37	50	48.0	45.8	1.32	0.433	48	106	453	115	E
FN 3453-60-115-E2_****	45	60	58	55	1.10	0.361	54	119	476	115	E
FN 3453-75-115-E2_****	56	75	72	69	0.882	0.297	57	126	634	115	F
FN 3453-100-115-E2_****	75	100	97	92	0.658	0.214	75	165	779	115	F
FN 3453-125-116-E2_****	93	125	120	114	0.531	0.178	106	234	788	116	G
FN 3453-150-116-E2_****	112	150	144	138	0.441	0.147	122	269	831	116	G
FN 3453-200-118-E2_****	149	200	192	183	0.331	0.106	156	344	1199	118	H
FN 3453-250-118-E2_*****	186	250	241	229	0.266	0.085	170	375	1022	118	H
FN 3453-300-118-E2_*****	224	300	290	277	0.220	0.073	222	489	1292	118	H

* Filter rating which does not require forced cooling or fan module

** Filter rating which does not require RC damping module for rectifiers with EMI filter

*** Motor drive input current without harmonic filter

**** Typical losses @ 45°C, 480V, 60Hz and rated load power

***** In order to apply FN 3453 filters, motor drives have to be equipped with either DC-link choke or AC line choke. The minimum required inductance values are given in mH in the filter selection table. If neither DC-link choke nor AC line choke is present, or if the minimum mH rating is not fulfilled, FN 3453 filter must not be used. In this case, FN 3452 need to be chosen.

Filter power terminals

Terminal designation*	Screw thread	Flex wire AWG	Flex wire		Screw torque value		Max width** cable lug [mm]	Frame size
			[mm ²]	[Nm]	[lbs-in]			
110	M3	14-22	0.4-2.5	0.5	4.4	7	A	
112	M4	10-22	0.4-6	1.2	10.6	10	B, C	
113	M6	6-18	0.75-16	3	26.6	15	D	
115	M8	1/0-8	10-50	8	70.8	15	E, F	
116	M8	3/0-8	10-95	8	70.8	17	G	
118	M10	3/0-500 kcmil	95-240	10	88.5	35	H	

* Recommended connector type: wire or cable lug for 110 to 113, only cable lug for 115 to 118

** To fulfill creepage/clearance acc. UL 61800-5-1 without additional protection (insulation). Creepage/clearance can vary depending on applicable standard and must be reviewed by customer. Creepage/clearance may be reduced when additional protection (insulation) is provided.

Filter signal and earth terminals

Terminal type	Screw thread	Screw torque value		Frame size
		[Nm]	[lbs-in]	
Signal	M3*	0.5	4.4	All
Earth (PE)	M5	2.2	19.5	A
Earth (PE)	M6	4	35.4	B, C
Earth (PE)	M8	9	79.7	D, E
Earth (PE)	M10	17	150.5	F, G, H

* Max width cable lug = 7 mm

Product selector

FN 34nn-xxx-yyy-

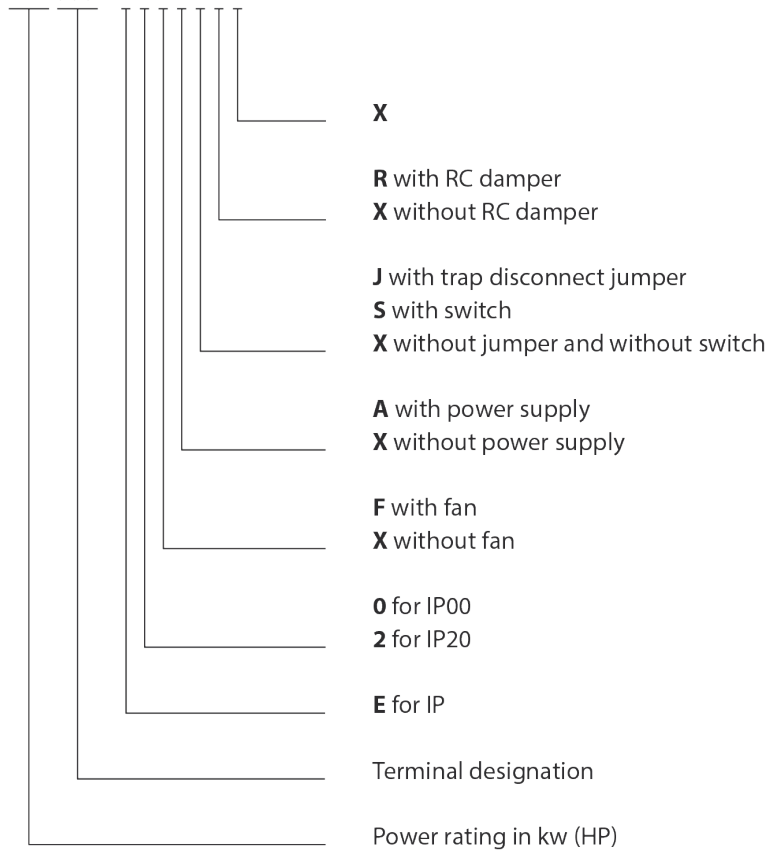
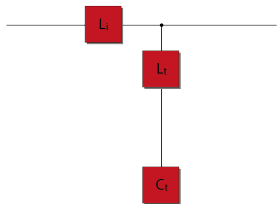

Table 1: Filter configurations if external air flow is available for cooling

(Filters do **not** contain fan and do **not** contain aux. power supply)

E0XXXXX

- For rectifiers with DC-link choke



E0XXJXX

- For rectifiers with DC-link choke
- Filters contain trap disconnect jumper

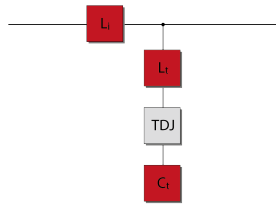

E0XXXRX

- For rectifiers with DC-link choke and with EMI filter
- Filters contain RC damper module

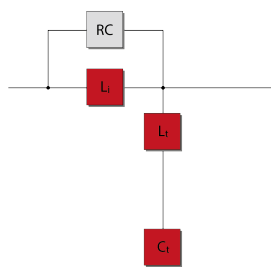

E0XXJRX

- For rectifiers with DC-link choke and with EMI filter
- Filters contain RC damper module and trap disconnect jumper

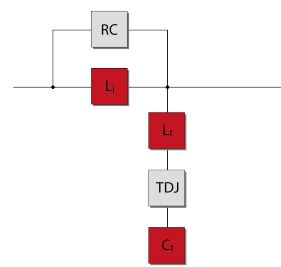

Table 2: Filter configurations with embedded ventilation

(Filters contain fan and aux. power supply)

E0FAXXX and E2FAXXX	E0FAJXX and E2FAJXX	E0FAXRX and E2FAXRX	E0FAJRX and E2FAJRX
<ul style="list-style-type: none"> - For rectifiers with DC-link choke - Filters contain fan and aux. power supply 	<ul style="list-style-type: none"> - For rectifiers with DC-link choke - Filters contain fan, aux. power supply and trap disconnect jumper 	<ul style="list-style-type: none"> - For rectifiers with DC-link choke and with EMI filter - Filters contain fan, aux. power supply and RC damper module 	<ul style="list-style-type: none"> - For rectifiers with DC-link choke and with EMI filter - Filters contain fan, aux. power supply, RC damper module and trap disconnect jumper

Table 3: Filter configurations if external aux. power supply for the fan is available

(Filters contain fan but do not contain aux. power supply, user should provide aux. power supply to the fan)

E0FXXXX and E2FXXXX	E0FXJXX and E2FXJXX	E0FXRX and E2FXRX	E0FXJRX and E2FXJRX
<ul style="list-style-type: none"> - For rectifiers with DC-link choke - Filters contain fan 	<ul style="list-style-type: none"> - For rectifiers with DC-link choke - Filters contain fan and trap disconnect jumper 	<ul style="list-style-type: none"> - For rectifiers with DC-link choke and with EMI filter - Filters contain fan and RC damper module 	<ul style="list-style-type: none"> - For rectifiers with DC-link choke and with EMI filter - Filters contain fan, RC damper module and trap disconnect jumper

Mechanical data of IP 00 enclosure

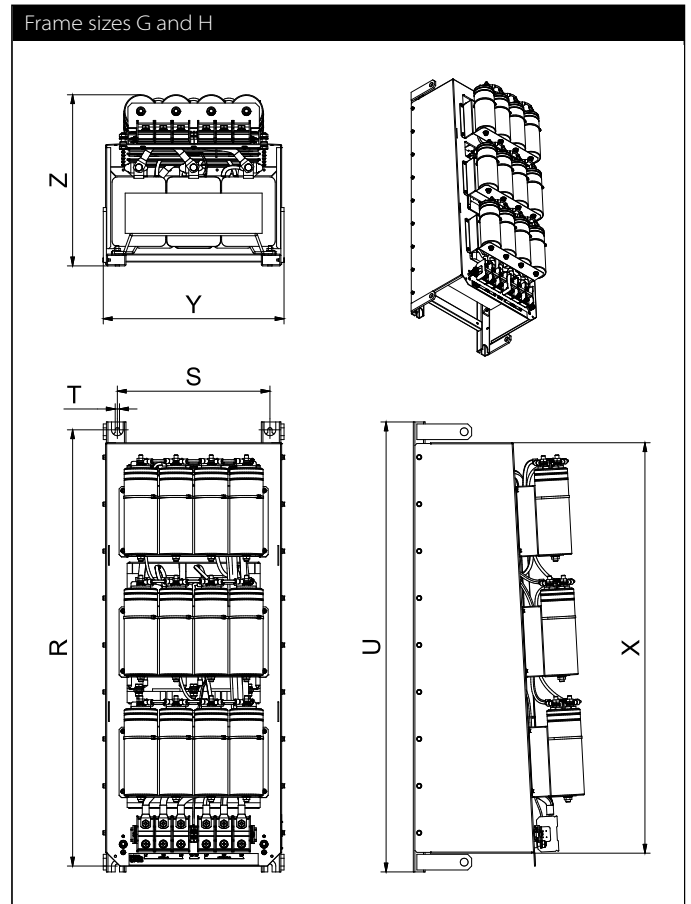
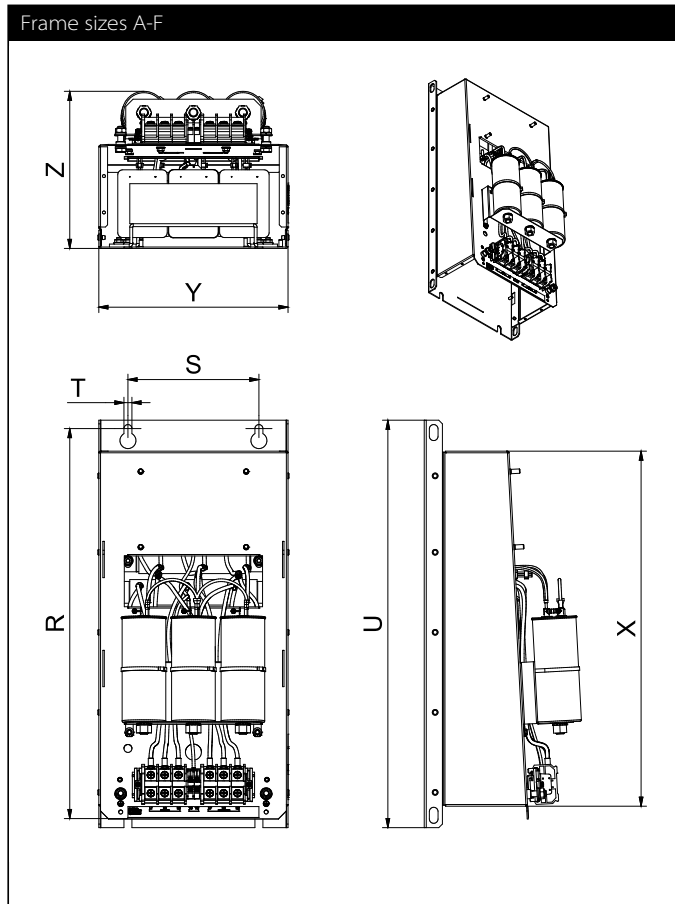

Dimensions

Frame	Dimensions in [mm]							Dimensions in [in]						
	Drill pattern			Base	Volume			Drill pattern			Base	Volume		
	R	S	T	U	X	Y	Z	R	S	T	U	X	Y	Z
A	340	120	7	360	302	160	185	13.4	4.7	0.3	14.2	11.9	6.3	7.3
B	405	120	7	425	370	180	206	15.9	4.7	0.3	16.7	14.6	7.1	8.1
C	460	150	7	483	430	210	221	18.1	5.9	0.3	19.0	16.9	8.3	8.7
D	540	180	11	560	491	260	252	21.3	7.1	0.4	22.0	19.3	10.2	9.9
E	680	220	11	705	635	290	319	26.8	8.7	0.4	27.8	25.0	11.4	12.6
F	730	250	11	752	684	340	343	28.7	9.8	0.4	29.6	26.9	13.4	13.5
G	920	280	11	960	863	353	386	36.2	11.0	0.4	37.8	34.0	13.9	15.2
H	1115	390	11	1150	1053	462	456	43.9	15.4	0.4	45.3	41.5	18.2	18.0

Inlet air flow required for cooling

Frame size	Min air volume*	
	[m³/h]	CFM [ft³/min]
A, B, C	0	0
D	128	75
E	204	120
F, G	408	240
H	612	360

* External air flow required for filter configurations without embedded ventilation

Mechanical data of IP 20 enclosure

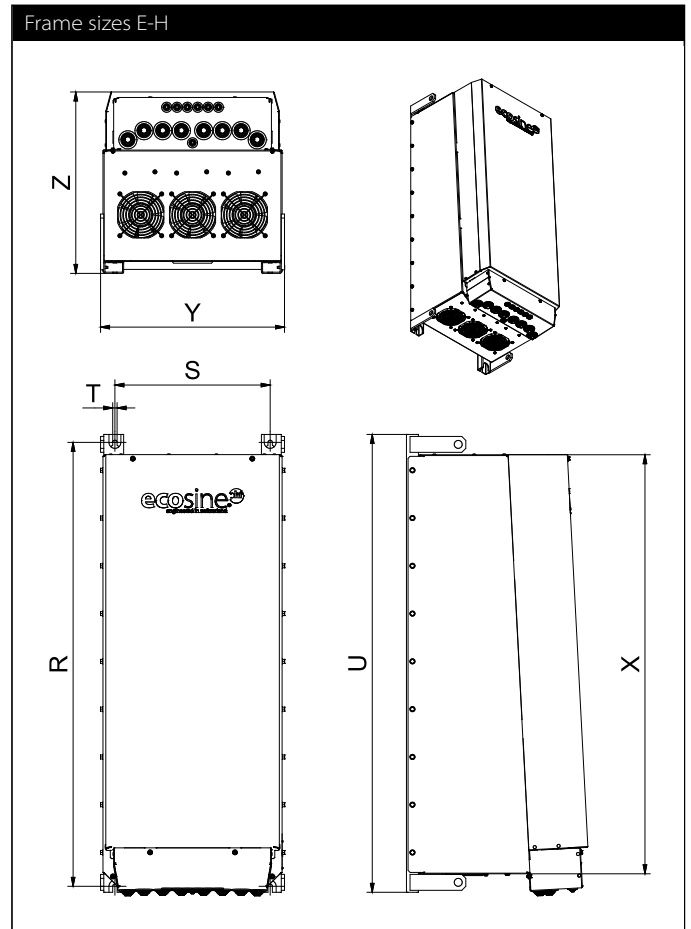
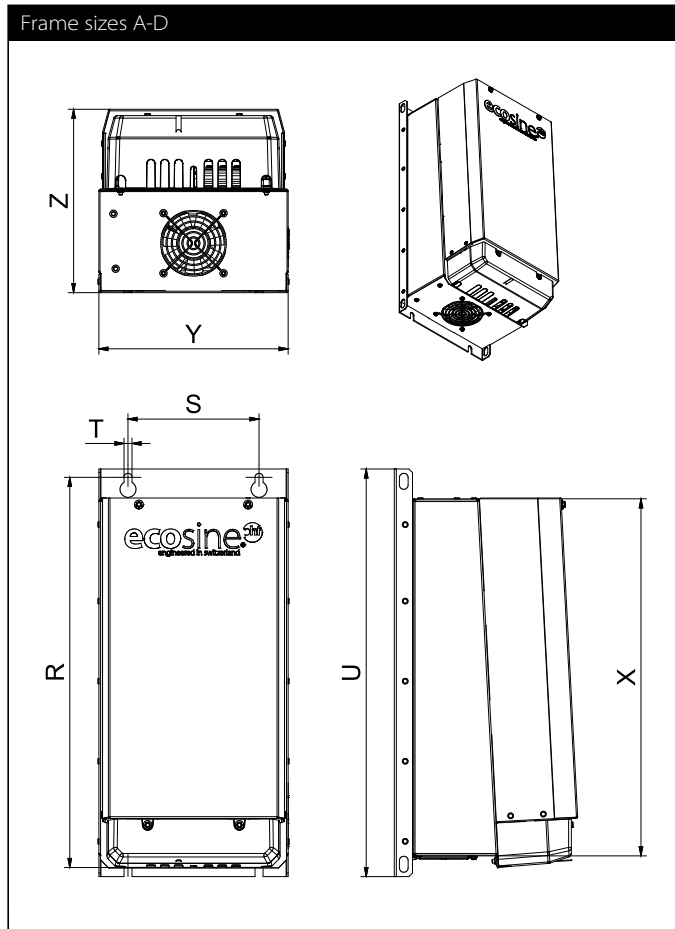

Dimensions

Frame	Dimensions in [mm]							Dimensions in [in]							
	R	Drill pattern			Base	Volume			R	Drill pattern			Base	Volume	
		S	T	U	X	Y	Z		S	T	U	X	Y	Z	
A	340	120	7	360	302	160	185	13.4	4.7	0.3	14.2	11.9	6.3	7.3	
B	405	120	7	425	370	180	206	15.9	4.7	0.3	16.7	14.6	7.1	8.1	
C	460	150	7	483	430	210	221	18.1	5.9	0.3	19.0	16.9	8.3	8.7	
D	540	180	11	560	491	260	252	21.3	7.1	0.4	22.0	19.3	10.2	9.9	
E	680	220	11	705	635	290	319	26.8	8.7	0.4	27.8	25.0	11.4	12.6	
F	730	250	11	752	684	340	343	28.7	9.8	0.4	29.6	26.9	13.4	13.5	
G	920	280	11	960	863	353	386	36.2	11.0	0.4	37.8	34.0	13.9	15.2	
H	1115	390	11	1150	1053	462	456	43.9	15.4	0.4	45.3	41.5	18.2	18.0	

Inlet air flow required for cooling

Frame size	Min air volume*	
	[m ³ /h]	CFM [ft ³ /min]
A, B, C	0	0
D	128	75
E	204	120
F, G	408	240
H	612	360

* External air flow required for filter configurations without embedded ventilation