

Output Filter for Motor Drives

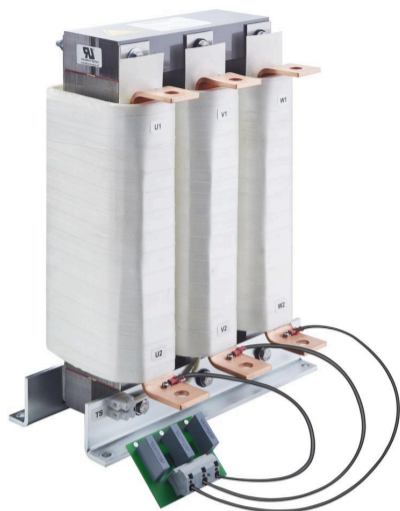

- Reduction of drive output voltage dv/dt
- Reduction of voltage stress at motor windings
- Protect AC motors from destructive effect of peak voltages
- Increase of motor service life
- Improvement of system reliability



Performance indicators

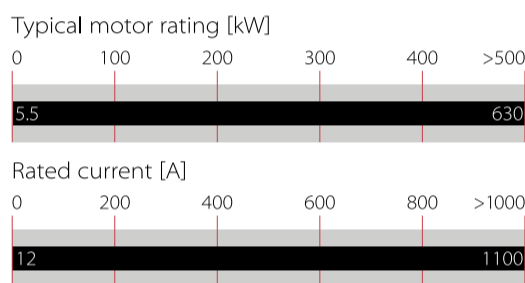

Approvals & Compliances



UL recognized up to 700 A

Features and Benefits

- Efficient reduction of high output voltage dv/dt from IGBT motor drives (as per IEC 60034-17/25)
- Restriction of overvoltages caused by line reflections on motor cables (as per IEC 60034-17/25)
- Protection of motor winding insulation from premature aging and destruction
- Increase service life of electric motors
- High reliability and production up time for mission critical applications
- Less interference propagation towards neighbouring equipment or lines
- Output filter with low impedance, ideal for processes requiring exceptional precision and reproducibility of movements

Technical Specifications

Nominal operating voltage	3x500 VAC
Rated operating voltage	3x550 VAC
Rated currents	12 to 1100 A @ 40°C
Motor frequency	0 to 60 Hz 0..60 Hz (with derating up to 120 Hz)
Switching frequency	2 to 16 kHz 2..16 kHz, depending on motor cable length and motor frequency -> refer graph on page 2
Typical dv/dt reduction	Factor 8 to 12
Max. peak voltage	≤1000 V
Voltage drop	<3 V @ 50 Hz
Ambient temperature range	-25°C to +40°C fully operational +40°C to +100°C with derating* -25°C to +100°C transport and storage
Overload capability	1.5 x rated current for 1 minute, ones per hour
Protection category	IP 00
Flammability corresponding to	UL 94V-2
Design corresponding to	UL 61800-5-1, EN 61800-5-1, EN 61558-2-20 or EN 60076-6

* Iderated = $Inominal \cdot \sqrt{\frac{(Tmax-Tamb)}{(Tmax-Tnominal)}} = Inom \cdot \sqrt{\frac{(100°C-Tamb)}{60°C}}$

Typical Applications

- Motor drive applications with short to medium motor cable length
- Machinery comprising servo or torque motors
- Conveyers
- HVAC equipment, incl. pumps, fans and compressors
- Elevators, hoisting and cranes
- Motor drives for process lines
- Applications where sine wave filters are not suited (e.g. high dynamic operation)

Typical electrical schematic

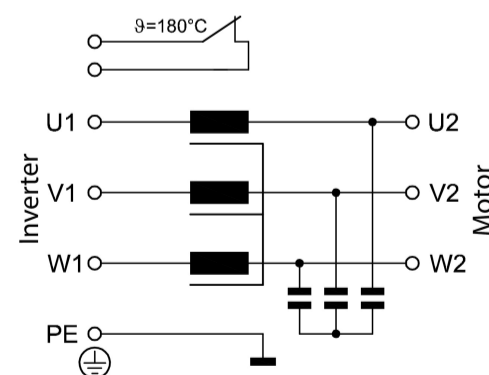

Filter Selection Table

Filter	Rated current @ 40°C/50 Hz [A]	Typical motor drive power rating @ 400 V* [kW]	Typical motor drive power rating @ 480 V** [kW]	Nominal inductance [mH]	Nominal capacitance [nF]	Typical power loss*** [W]	Voltage drop**** [V]	Input/ Output connections	Weight [kg]
FN 5060-12-84	12	5.5	6.6	0.095	4.7	53	0.4	-84	1
FN 5060-24-84	24	11	13.2	0.098	4.7	55	0.7	-84	1.6
FN 5060-30-99	30	15	18	0.254	33	143	2.4	-99	6.3
FN 5060-45-99	45	22	26.4	0.17	33	182	2.4	-99	6.3
FN 5060-60-99	60	30	36	0.127	33	189	2.4	-99	7.4
FN 5060-70-99	70	37	44.4	0.109	33	214	2.4	-99	8.6
FN 5060-90-99	90	45	52.8	0.085	33	254	2.4	-99	10.4
FN 5060-110-99	110	55	66	0.069	33	316	2.4	-99	11.5
FN 5060-150-99	150	75	90	0.051	68	449	2.4	-99	14.6
FN 5060-180-99	180	90	108	0.042	68	464	2.4	-99	18.0
FN 5060-250-99	250	132	158.4	0.031	68	508	2.4	-99	22.1
FN 5060-320-99	320	160	192	0.024	68	604	2.4	-99	29.6
FN 5060-400-99	400	200	240	0.019	68	637	2.4	-99	32.2
FN 5060-500-99	500	250	300	0.015	68	471	2.4	-99	54.5
FN 5060-600-99	600	315	378	0.013	100	437	2.5	-99	63.5
FN 5060-700-99	700	400	480	0.011	100	486	2.4	-99	74.0
FN 5060-900-99	900	500	600	0.008	100	597	2.3	-99	86.5
FN 5060-1100-99	1100	630	756	0.007	100	695	2.4	-99	114.0

* General purpose four-pole (1500 r/min) AC induction motor rated 400 V/50 Hz.

** General purpose four-pole (1500 r/min) AC induction motor rated 480 V/50 Hz.

*** Power loss at 2 kHz switching frequency/80 m motor cable length. Exact value depends upon the motor cable type and length, switching frequency and further stray parameters within the system.

**** Voltage drop at rated current and 50 Hz.

Switching Frequency Vs. Motor Cable Length

Ensure the motor drive switching frequency is set to the required switching frequency (see filter selection table). Check the drives manual whether special settings are necessary. For any questions please contact the drives manufacturer.

Refer also to the “fPWM/cable length” diagram below:

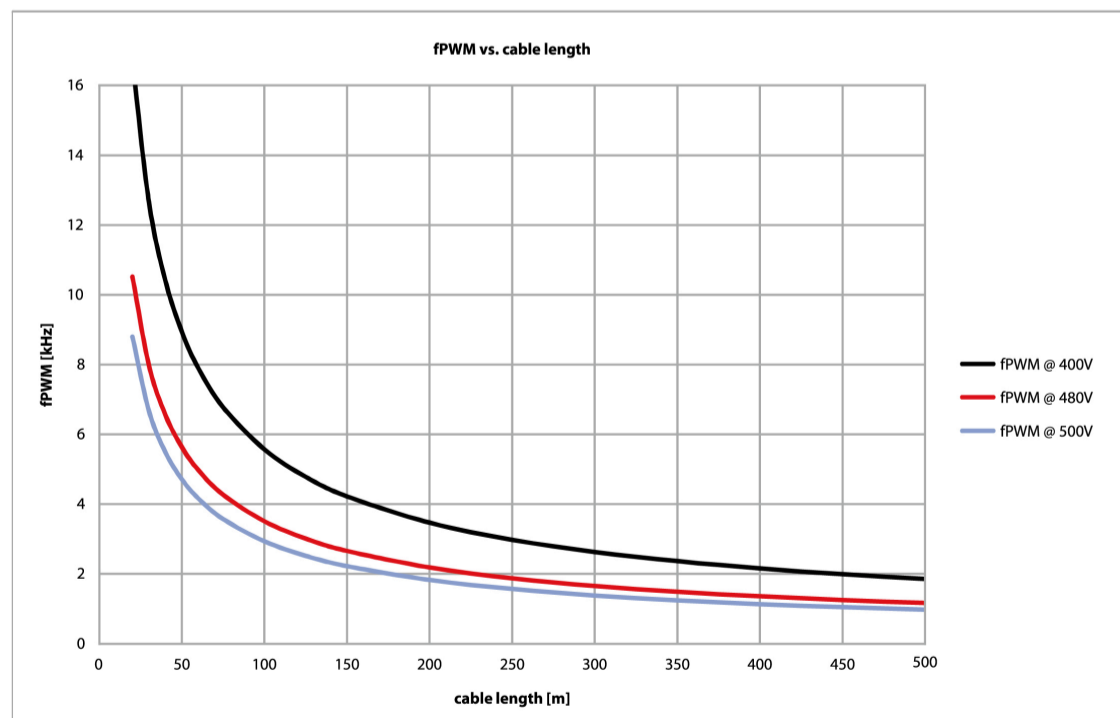

Temperature Monitoring Function

The temperature monitoring device opens a potential-free contact in the case of filter overtemperature (>180°C). The maximum switching capability is 5 A/240 V. The switch can be used, for example, in the input of a CNC controller or as the trip of a circuit breaker in order to interrupt the mains power supply.

Mechanical Data

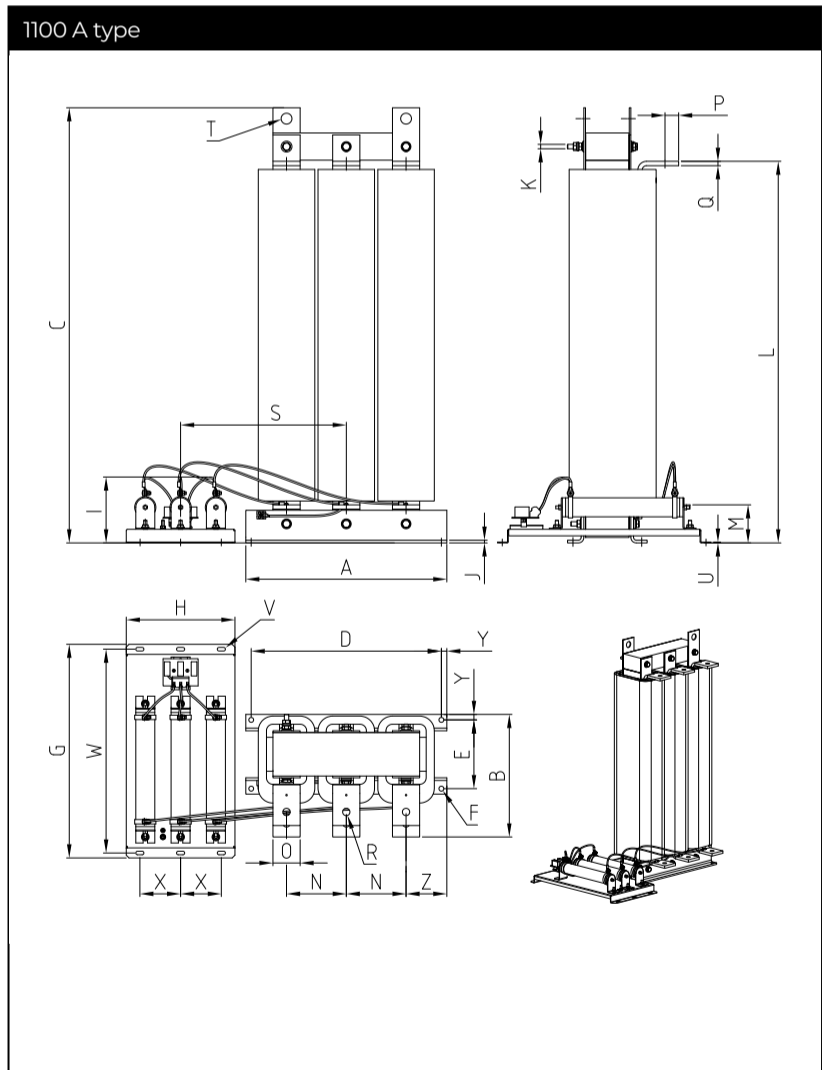
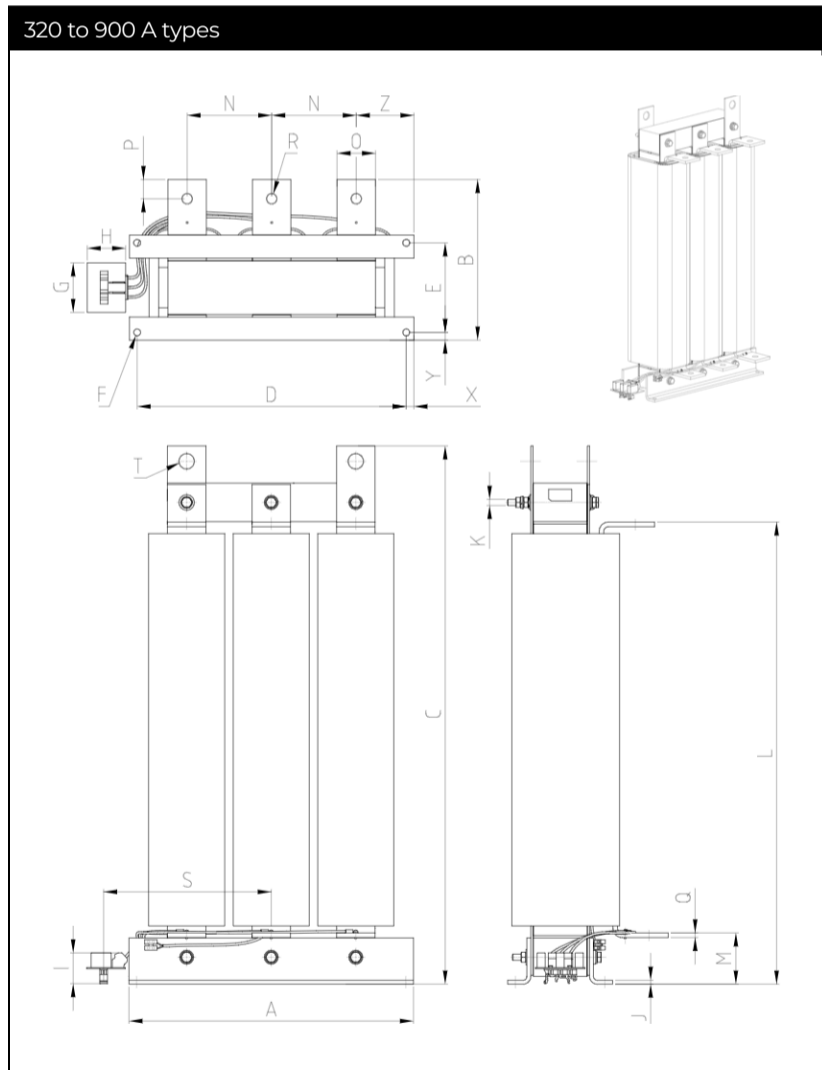
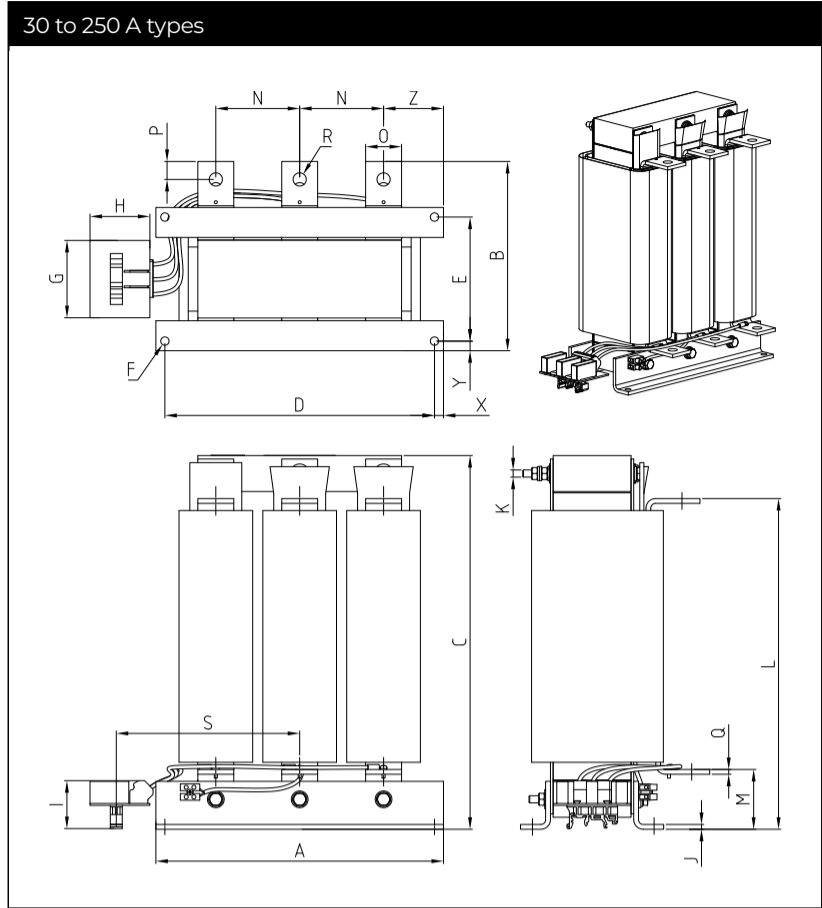
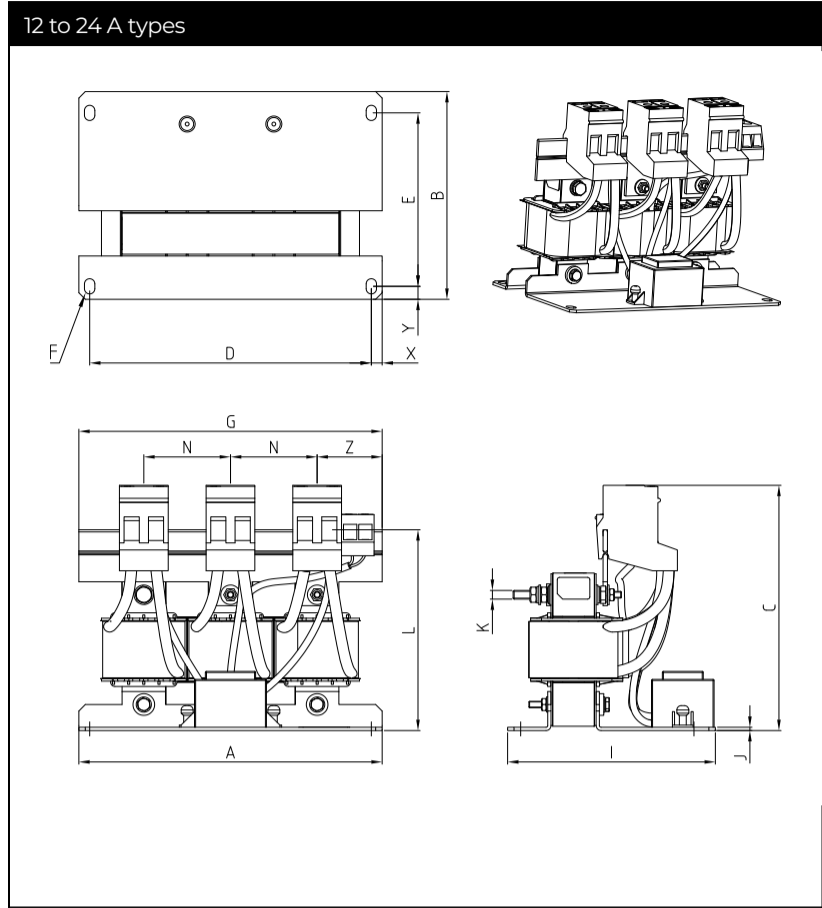

Dimensions (12 - 250 A)

	12 A	24 A	30 A	45 A	60 A	70 A	90 A	110 A	150 A	180 A	250 A
A	125	140	240	240	240	240	240	240	240	240	240
B	85.5	96	109	110	110	121	130	136	141.5	142.5	158
C	104	113	151	151	181	222	221	221	254	310	312
D	115	130	225	225	225	225	225	225	225	225	225
E	70	80	66.5	66.5	66.5	66.5	76.5	81.5	86.5	88.5	103.5
F	7x4.8	7x4.8	Ø7(4x)	Ø7(4x)	Ø7(4x)	Ø7(4x)	Ø7(4x)	Ø7(4x)	Ø7(4x)	Ø7(4x)	Ø7(4x)
G	120	140	64.5	64.5	64.5	64.5	64.5	64.5	64.5	64.5	64.5
H			50	50	50	50	50	50	50	50	50
I			40	40	40	40	40	40	40	40	40
J			4	4	4	4	4	4	4	4	4
K	M4	M4	M6	M6	M6	M6	M6	M6	M6	M6	M6
L	84	93	120	121	148	181	181	181	222	275	276
M			43	44	46	54	54	54	46	49	50
N	34.5	40	70	70	70	70	70	70	70	70	70
O			20	20	20	30	30	30	30	30	30
P											
Q			3	3	3	3	3	3	4	4	4
R			Ø9(6x)	Ø9(6x)	Ø9(6x)	Ø11(6x)	Ø11(6x)	Ø11(6x)	Ø11(6x)	Ø11(6x)	Ø11(6x)
S	max. 360	max. 360	max. 360	max. 360	max. 360	max. 360	max. 360	max. 360	max. 360	max. 360	
T											
U											
V											
W											
X	5	5	7.5	7.5	7.5	7.5	7.5	7.5	7.5	7.5	7.5
Y	6	6	8	8	8	8	8	8	8	8	8
Z	27.5	30									

All dimensions in mm-; 1 inch = 25.4 mm

Tolerances according: ISO 2768-m/EN 22768-m

Dimensions (320 -1100 A)

	320 A	400 A	500 A	600 A	700 A	900 A	1100 A
A	240	240	370	370	370	370	370
B	165	174	197	199	209	209	225
C	438	438	499	598	599	700	801
D	225	225	350	350	350	350	350
E	103.5	108.5	106.5	106.5	116.5	116.5	126.5
F	Ø7(4x)	Ø7(4x)	Ø9(4x)	Ø9(4x)	Ø9(4x)	Ø9(4x)	Ø9(4x)
G	64.5	64.5	64.5	64.5	64.5	64.5	393
H	50	50	50	50	50	50	200
I	40	40	40	40	40	40	120
J	4	4	5	5	5	5	5
K	M6	M6	M8	M8	M8	M8	M8
L	375	375	401	500	501	601	702
M	51	51	66	65	67	67	70
N	70	70	110	110	110	110	110
O	30	30	50	50	50	50	50
P	15	15	25	25	25	25	25
Q	6	6	5	5	6	6	8
R	Ø11(6x)	Ø11(6x)	Ø13.5(6x)	Ø13.5(6x)	Ø13.5(6x)	Ø13.5(6x)	Ø13.5(6x)
S	max. 360	max. 360	max. 420	max. 420	max. 420	max. 420	max. 550
T	Ø18(2x)	Ø18(2x)	Ø20(2x)	Ø20(2x)	Ø20(2x)	Ø20(2x)	Ø20(2x)
U							1.5
V							6.5
W							375
X	7.5	7.5	10	10	10	10	75
Y	8	8	10	10	10	10	10
Z							

All dimensions in mm; 1 inch = 25.4 mm

Tolerances according: ISO 2768-m/EN 22768-m

Filter Input/Output Cross Sections

	-84
Solid wire	6 mm ²
Flex wire	4 mm ²
AWG type wire	AWG 10
Recommended torque	0.6-0.8 Nm

Please note:

The input/output cross sections have to be of equal or bigger size as the cross section of the filter bus bar terminals.

Make sure to consult and respect local, national and international safety codes.

Connect the protective earth terminal(s) first, before attempting to connect phase terminals.

Please consult the documents „Mounting and Installation Guidelines“ being shipped with the product.

For additional information please consult the document „Basis in EMC and Power Quality“, published in the download section of www.schaffner.com.