

Output Filter for Motor Drives



- Reduction of drive output voltage dv/dt
- Reduction of voltage stress at motor windings
- Protect AC motors from destructive effect of peak voltages
- Increase of motor service life
- Improvement of system reliability



Performance indicators

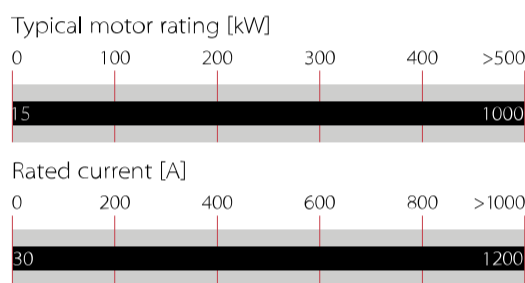

Approvals & Compliances



UL recognized up to 320 A

Features and Benefits

- Efficient reduction of high output voltage dv/dt from IGBT motor drives (as per IEC 60034-17/25)
- Restriction of overvoltages caused by line reflections on motor cables (as per IEC 60034-17/25)
- Protection of motor winding insulation from premature aging and destruction
- Increase service life of electric motors
- Patented solution without capacitors and resistors for ease of installation and increased reliability
- Less interference propagation towards neighbouring equipment or lines
- Output filter with low impedance, ideal for processes requiring exceptional precision and reproducibility of movements

Technical Specifications

Max. operating voltage	3 ph 760 VAC
Rated currents	30 to 1200 A @ 40°C
Motor frequency	0..60 Hz (with derating up to 120 Hz)
Switching frequency	up to 16 kHz, depending on motor cable length and motor frequency -> refer graph on page 2
Typical dv/dt reduction	Factor 8 to 12
Max. peak voltage	≤1850 V (according EN 60034-25B)
Voltage drop	<3 V @ 50 Hz
Rated temperature	+40°C without derating up to 100°C
Operation temperature	-25°C to +100°C (25/100/21)
Transportation and storage temperature	-40°C to +100°C (25/100/21)
Overload capability	1.5 x rated current for 1 minute, once per hour
Protection category	IP 00
Flammability corresponding to	UL 94V-2
Design corresponding to	UL 61800-5-1, CSA 22.2 No.14, EN 61558-2-20

Typical Applications

- Motor drive applications with short to medium motor cable length
- Machinery comprising servo or torque motors
- Submersible- and irrigation pumps
- HVAC equipment, incl. pumps, fans and compressors
- Elevators, hoisting and cranes
- Motor drives for process lines
- Applications where sine wave filters are not suited (e.g. high dynamic operation)

Typical electrical schematic

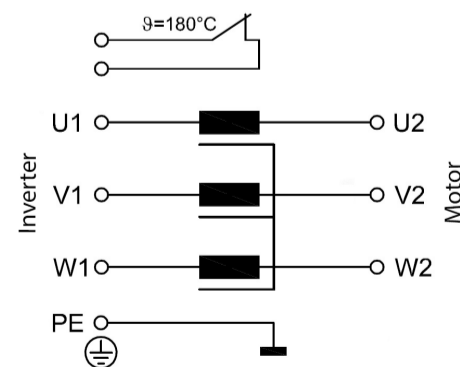

Filter Selection Table

Filter	Rated current @ 40°C/50 Hz [A]	Nominal inductance [mH]	**Typical power loss [W]	Input/ Output connections	Weight [kg]
FN 5060 HV-30-99	30	0.17	641	-99	12
FN 5060 HV-45-99	45	0.17	653	-99	12.5
FN 5060 HV-75-99	75	0.1	478	-99	23
FN 5060 HV-115-99	115	0.069	394	-99	27
FN 5060 HV-165-99	165	0.051	301	-99	36
FN 5060 HV-220-99	220	0.035	371	-99	44
FN 5060 HV-320-99	320	0.023	383	-99	59
FN 5060 HV-450-99	450	0.019	376	-99	68
FN 5060 HV-660-99	660	0.012	455	-99	100
FN 5060 HV-900-99	900	0.009	550	-99	111
FN 5060 HV-1200-99	1200	0.007	670	-99	139

* General purpose four-pole (1500 r/min) AC induction motor rated 690 V/50 Hz.

** Power loss at 2 kHz switching frequency/80 m motor cable length. Exact value depends upon the motor cable type and length, switching frequency and further stray parameters within the system.

Switching Frequency Vs. Motor Cable Length

Ensure the motor drive switching frequency is set to the required switching frequency (see filter selection table). Check the drives manual whether special settings are necessary. For any questions please contact the drives manufacturer.

Refer also to the “fPWM/cable length” diagram below:

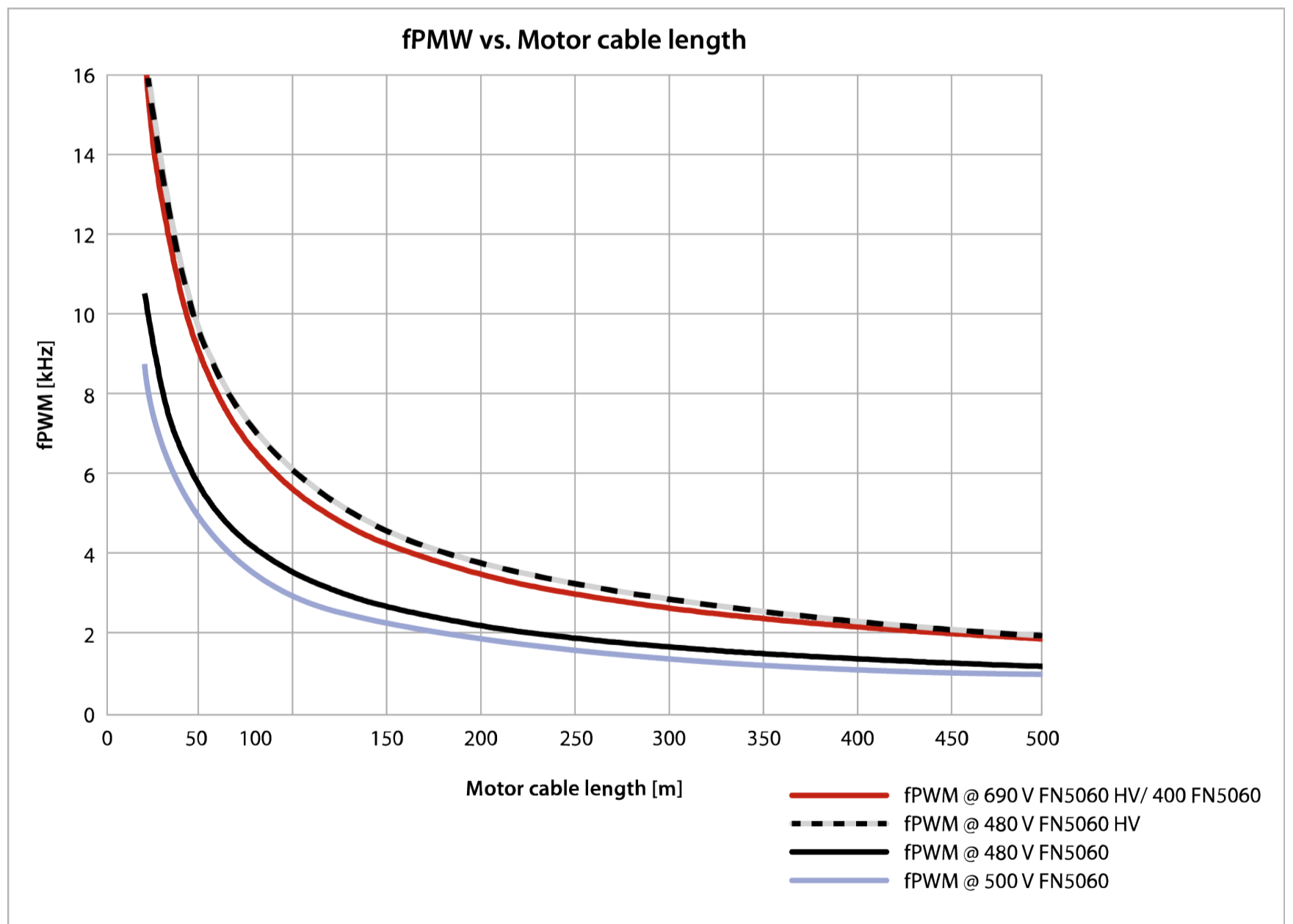

Temperature Monitoring Function

The temperature monitoring device opens a potential-free contact in the case of filter overtemperature (>180°C). The maximum switching capability is 5 A/240 V. The switch can be used, for example, in the input of a CNC controller or as the trip of a circuit breaker in order to interrupt the mains power supply.

Mechanical Data

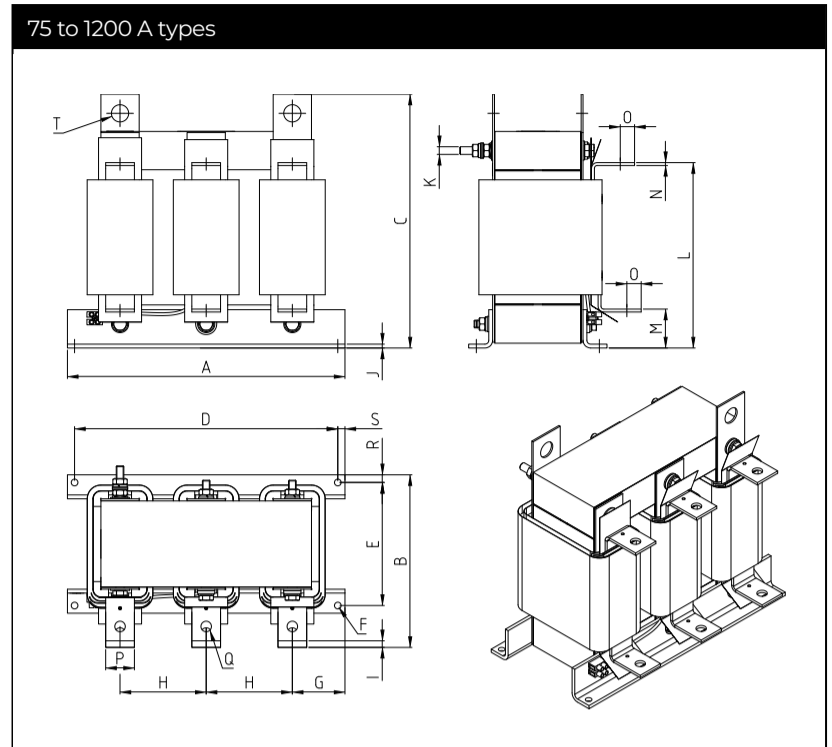
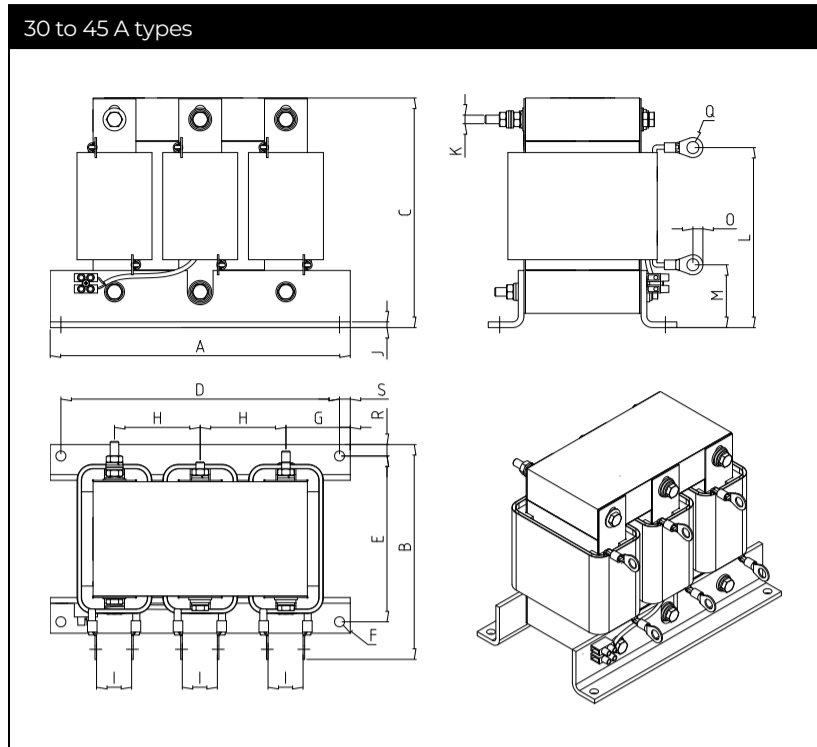

Dimensions

	30 A	45 A	75 A	115 A	165 A	220 A	320 A	450 A	660 A	900 A	1200 A
A	210	210	290	290	290	290	390	390	390	390	390
B	138	143	168	180	191	211	187	209	220	229	260
C	161	161	265	265	314	314	444	496	546	595	642
D +/-0.7	195	195	275	275	275	275	366	366	366	366	366
E +/-0.7	111	116	113.5	128.5	138.5	158.5	120.5	120.5	130.5	140.5	160.5
160.5F	Ø7(4x)	Ø7(4x)	Ø7(4x)	Ø7(4x)	Ø7(4x)	Ø7(4x)	Ø9(4x)	Ø9(4x)	Ø9(4x)	Ø9(4x)	Ø9(4x)
G	45	45	55	55	55	55	75	75	75	75	75
H	60	60	90	90	90	90	120	120	120	120	120
I	25	25	9	7	8	8	10	10	11	10	17
J	4	4	4	4	4	4	5	5	5	5	5
K	M6	M6	M8	M8	M8	M8	M8	M8	M8	M8	M8
L	126	126	194	194	245	244	331	381	432	481	533
M	44	44	41	41	41	40	75	76	76	75	75
N			3	3	4	4	6	5	6	6	8
O	7	7	15	15	15	15	15	25	25	25	25
P			30	30	30	30	30	50	50	50	50
Q	Ø8(6x)	Ø8(6x)	Ø11(6x)	Ø11(6x)	Ø11(6x)	Ø11(6x)	Ø11(6x)	Ø13.5(6x)	Ø13.5(6x)	Ø13.5(6x)	Ø13.5(6x)
R	8	8	8	8	8	8	12	12	12	12	12
S	7.5	7.5	7.5	7.5	7.5	7.5	12	12	12	12	12
T			Ø18(2x)	Ø18(2x)	Ø18(2x)	Ø18(2x)	Ø20(2x)	Ø20(2x)	Ø20(2x)	Ø20(2x)	Ø20(2x)

All dimensions in mm-; 1 inch = 25.4 mm

Tolerances according: ISO 2768-v/EN 22768-v, if not stated otherwise

Please note:

Make sure to consult and respect local, national and international safety codes.

Connect the protective earth terminal(s) first, before attempting to connect phase terminals.

Please consult the documents „Mounting and Installation Guidelines“ being shipped with the product.

For additional information please consult the document „Basis in EMC and Power Quality“, published in the download section of www.schaffner.com.