

High Performance EMC/EMI Filter



- Rated currents up to 15 A
- Excellent attenuation performance
- Complies with IEC/EN 60601-1
- Snap-in versions (S and S1 type)
- Hot inlet versions (HI type)



Performance indicators

Attenuation performance



Rated current [A]



Technical Specifications

Maximum continuous operating voltage	250 VAC, 50/60 Hz
Flammability corresponding to	UL 94 V-2 or better
Surge pulse protection (Z type)	Helps compliance to IEC61000-4-5 (Differential Mode only)
Operating frequency	DC to 400 Hz
Rated currents	1 to 15 A @ 50°C
Approvals by rated current	1 to 10 A (ENEC, CQC) 1 to 15 A (UL, CSA)
High potential test voltage	P → PE 2000 VAC for 2 sec (standard types) P → PE 2500 VAC for 2 sec (B types) P → N 1000 VAC for 2 sec
Protection category	IP 40 according to IEC 60529
Temperature range (operation and storage)	-25°C to +85°C (25/85/21)
Design corresponding to	UL 1283, CSA 22.2 No. 8 1986, IEC/EN 60939

Approvals & Compliances



(CQC except HI-types)

The FN 9233 IEC inlet filter combines an excellent IEC inlet and mains filter with excellent filter attenuation in a small form factor. Choosing the FN 9233 product line brings you the rapid availability of a standard filter associated with the necessary safety acceptances. Standard IEC connector filters are a practical solution helping you to pass EMI system approval in a short time. A wide selection on amperage ratings, output connections, mounting possibilities and filters for medical applications are designed to offer you the desired solution. For types with additional earth line choke please consult the FN 9233 E data sheet.

Features and Benefits

- Exceptional conducted attenuation performance, based on chokes with high saturation resistance and excellent thermal behavior
- Rear/front or snap-in mounting
- Optional earth line choke see FN 9233 E data sheet
- FN 9233 B versions comply with the requirements of 1MOP acc. to IEC/EN 60601-1 for creepage and clearance, leakage current and high potential testing
- Wide mounting flanges available
- Different output connections offering maximum flexibility for assembly
- Custom-specific versions are available on request

Typical Applications

- Portable electrical and electronic equipment
- Small to medium-sized machines and household equipment
- Single-phase power supplies, switch-mode power supplies
- Test and measurement equipment
- Medical equipment
- Rack mounting equipment

Filter Selection Table

Filter	Rated current @ 50°C (25°C)	Leakage current* @ 250 VAC/50 Hz (@ 120 VAC/60 Hz)	Inductance L	Capacitance			Resistance R	Output connections 	Weight [g]
				Cx1	Cx2	Cy			
	[A]	[mA]	[mH]	[μF]	[μF]	[nF]	[kΩ]		
FN9233 x-1-06	1 (1.2)	0.31 (0.18)	22.5	0.1		2.2		-06	37
FN9233 x-3-06	3 (3.5)	0.31 (0.18)	4.6	0.1		2.2		-06	37
FN9233 x-6-06	6 (7.2)	0.31 (0.18)	1.6	0.1		2.2		-06	37
FN9233 x-8-06	8 (10.6)	0.31 (0.18)	0.9	0.1		2.2		-06	37
FN9233 x-10-06	10 (11.6)	0.31 (0.18)	0.45	0.1		2.2		-06	37
FN9233 x-12-06	12 (12)	0.31 (0.18)	0.27	0.1		2.2		-06	37
FN9233 x-15-06	15 (15)	0.31 (0.18)	0.2	0.1		2.2		-06	37
FN9233 x-12-06HI	12 (12)	0.31 (0.18)	0.27	0.1		2.2		-06	37
FN9233 x-15-06HI	15 (15)	0.31 (0.18)	0.2	0.1		2.2		-06	37
FN9233 xR-1-06	1 (1.2)	0.31 (0.18)	22.5	0.1		2.2	1000	-06	37
FN9233 xR-3-06	3 (3.5)	0.31 (0.18)	4.6	0.1		2.2	1000	-06	37
FN9233 xR-6-06	6 (7.2)	0.31 (0.18)	1.6	0.1		2.2	1000	-06	37
FN9233 xR-8-06	8 (10.6)	0.31 (0.18)	0.9	0.1		2.2	1000	-06	37
FN9233 xR-10-06	10 (11.6)	0.31 (0.18)	0.45	0.1		2.2	1000	-06	37
FN9233 xR-12-06	12 (12)	0.31 (0.18)	0.27	0.1		2.2	1000	-06	37
FN9233 xR-15-06	15 (15)	0.31 (0.18)	0.2	0.1		2.2	1000	-06	37
FN9233 xR-12-06HI	12 (12)	0.31 (0.18)	0.27	0.1		2.2	1000	-06	37
FN9233 xR-15-06HI	15 (15)	0.31 (0.18)	0.2	0.1		2.2	1000	-06	37
FN9233 xB-1-06	1 (1.2)	0.00	22.5	0.1			1000	-06	37
FN9233 xB-3-06	3 (3.5)	0.00	4.6	0.1			1000	-06	37
FN9233 xB-6-06	6 (7.2)	0.00	1.6	0.1			1000	-06	37
FN9233 xB-8-06	8 (10.6)	0.00	0.9	0.1			1000	-06	37
FN9233 xB-10-06	10 (11.6)	0.00	0.45	0.1			1000	-06	37
FN9233 xB-12-06	12 (12)	0.00	0.27	0.1			1000	-06	37
FN9233 xB-15-06	15 (15)	0.00	0.2	0.1			1000	-06	37
FN9233 xB-12-06HI	12 (12)	0.00	0.27	0.1			1000	-06	37
FN9233 xB-15-06HI	15 (15)	0.00	0.2	0.1			1000	-06	37
FN9233 UF2-1-06	1 (1.2)	0.47 (0.27)	22.5	0.047	0.047	3.3		-06	46
FN9233 UF2-3-06	3 (3.5)	0.47 (0.27)	4.6	0.047	0.047	3.3		-06	46
FN9233 UF2-6-06	6 (7.2)	0.47 (0.27)	1.6	0.047	0.047	3.3		-06	46
FN9233 UF2-8-06	8 (10.6)	0.47 (0.27)	0.9	0.047	0.047	3.3		-06	46
FN9233 UF2-10-06	10 (11.6)	0.47 (0.27)	0.45	0.047	0.047	3.3		-06	46
FN9233 UF2-12-06	12 (12)	0.47 (0.27)	0.27	0.047	0.047	3.3		-06	46
FN9233 UF2-15-06	15 (15)	0.47 (0.27)	0.2	0.047	0.047	3.3		-06	46

* Maximum leakage under normal operating conditions (acc. to IEC60939-3). Note: if the neutral line is interrupted, worst case leakage could reach twice this level.

Product selector

Typical electrical schematic

FN 9233xx-yy-..HI-zz

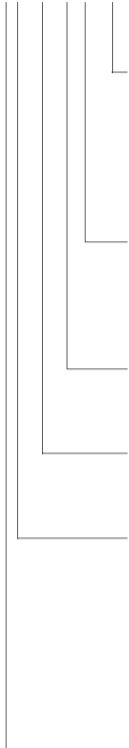

- Snap-in range for S version only
- Blank: Snap-in range 0.7 to 1.5mm
- 20: Snap-in range 1.5 to 2.2mm

- Blank: Standard IEC inlet type C14
- HI: Hot IEC inlet type C16 (12 and 15A types only)

- 06: Faston 6.3 x 0.8mm (spade/soldering)

- 1 to 15: Rated current

- Blank: Standard version
- R: Bleed resistor
- B: Medical version (with bleed resistor and without Y2-capacitor)
- F2: 2 X-capacitors and higher Y-capacitor value

- Blank: Standard housing with mounting flanges
- U: Housing with wider mounting flanges
- S: Snap-in version, snapper on vertical side
- S1: Snap-in version, snapper on horizontal side

Standard, R and B types

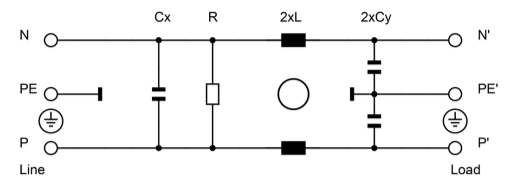

F2 types

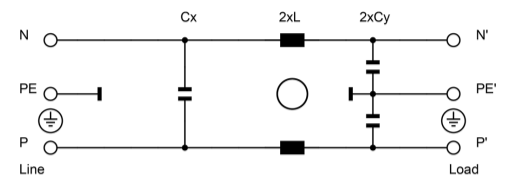

For example: FN 9233-15-06, FN 9233 S1B-10-06-20, FN 9233 R-12-06HI

Typical Filter Attenuation

Per CISPR 17; A=50 Ω/50 Ω sym; B=50 Ω/50 Ω asym; C=0.1 Ω/100 Ω sym; D=100 Ω/0.1 Ω sym

FN 9233: 1 and 3 A types

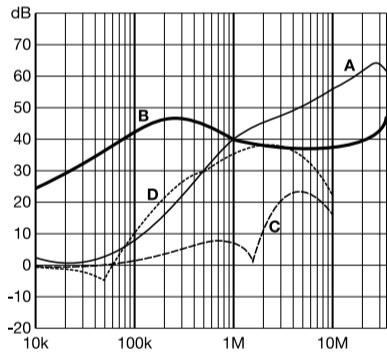

FN 9233: 6 to 10 A types

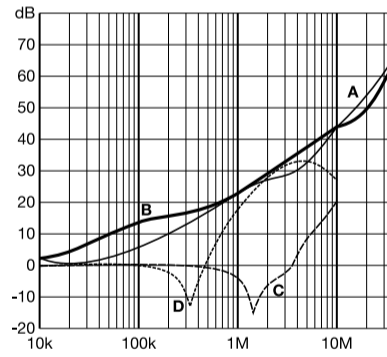

FN 9233: 12 and 15 A types

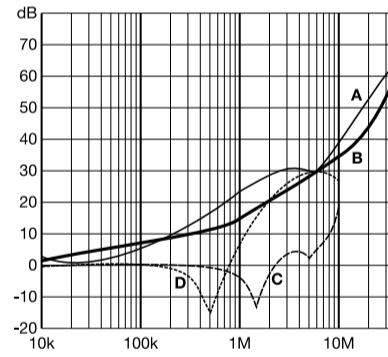

FN 9233 UF2: 1 and 3 A types

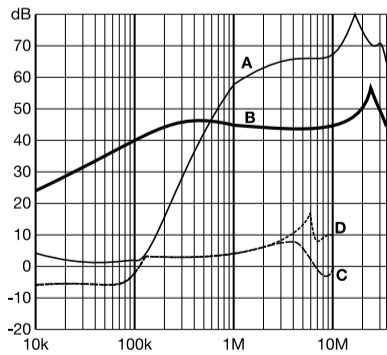

FN 9233 UF2: 6 to 10 A types

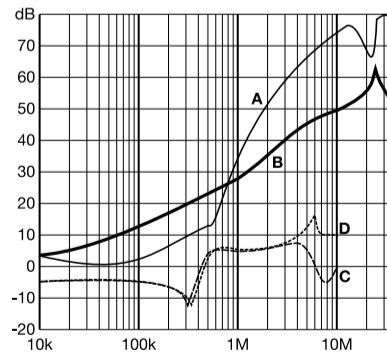

FN 9233 UF2: 12 and 15 A types

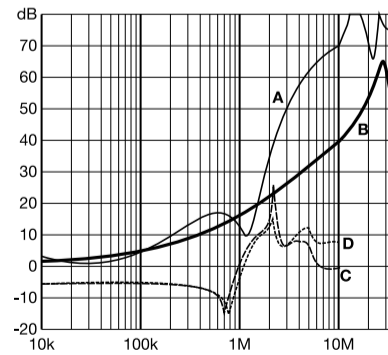

Mechanical Data

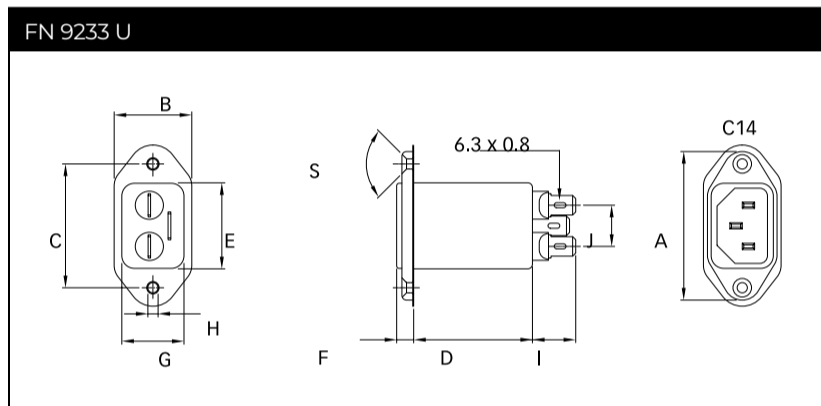
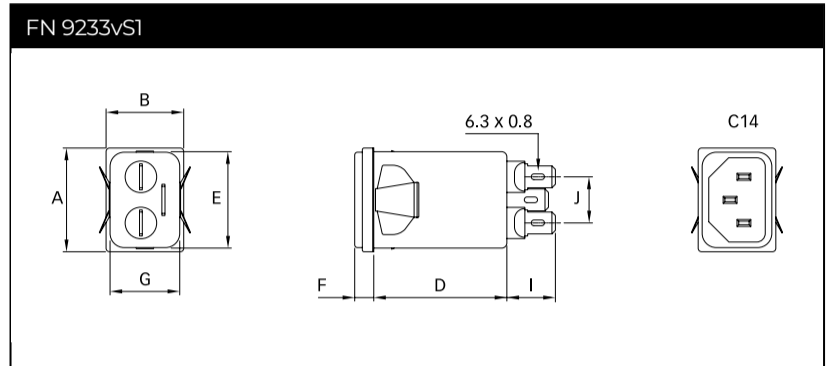
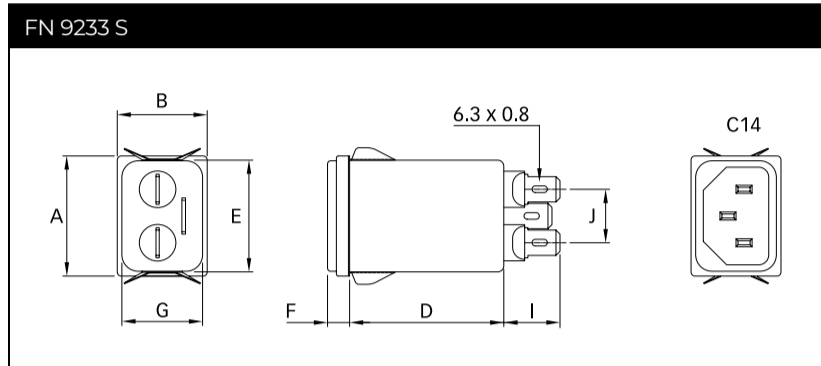
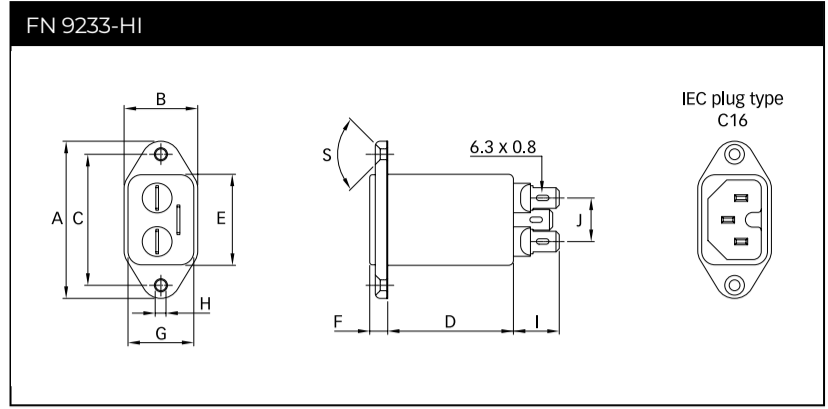
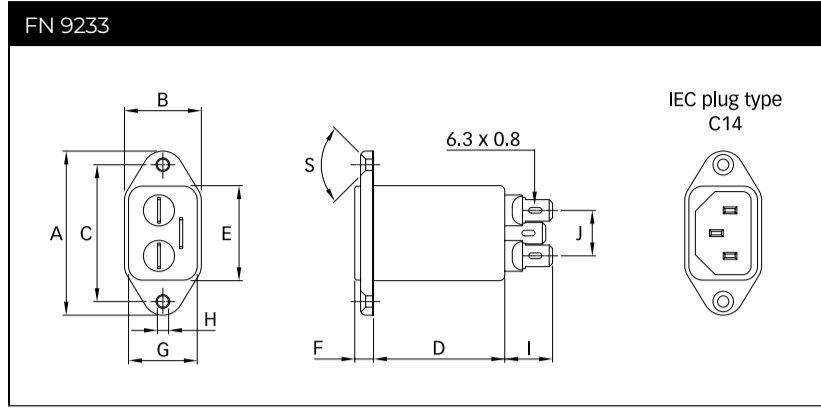

FN 9233 UF2: 1 and 3 A types

FN 9233 UF2: 6 to 10 A types

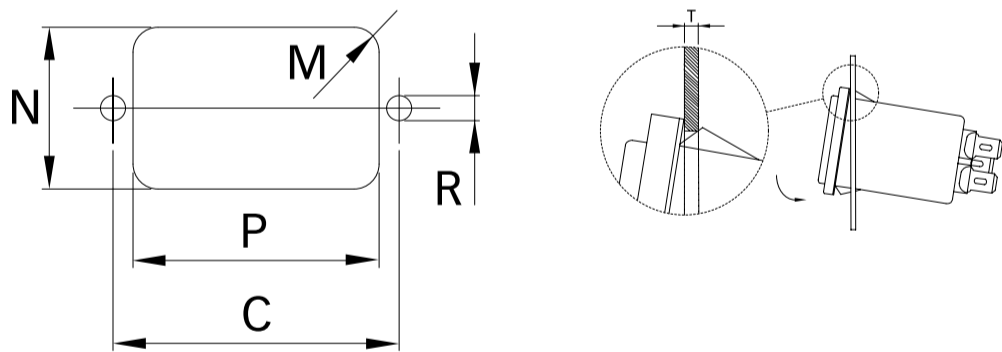

Dimensions

	FN 9233	FN 9233 U	FN 9233 UF2	FN 9233 S	FN 9233 S1	FN 9233-HI	Tol.
A	48	48	48	29.9	29.9	48	
B	22.4	25	25	22.4	22.4	22.4	
C	40	40	40			40	±0.2
D	38.25	38.25	47.1	38.25	38.25	38.25	
E	27.8	27.7	27.7	27.8	27.8	27.8	+0.6/-0
F	5.7	5.7	5.7	5.7	5.7	5.7	
G	20.1	20.1	20.1	20.1	20.1	20.1	+0.6/-0
H	Ø3.3	Ø3.3	Ø3.3			Ø 3.3	
I	14	14	14	14	14	14	
J	13.3	13.3	13.3	13.3	13.3	13.3	
M	R ≤3	R ≤3	R ≤3	R ≤1.5	R ≤1.5	R ≤3	
N	21.5	21.5	21.5	20.8	21.9	21.5	
P	28.5	28.5	28.5	29.4	28.5	28.5	
R*	M3	M3	M3			M3	
S	90°	90°	90°			90°	
T**				0.7 - 1.5	0.7 - 1.5		
T**				1.5 - 2.2	1.5 - 2.2		

* Recommended torque for M3 (90° countersunk flat head) is 0.5 Nm

** For selecting the panel thickness, please refer to the filter selector table.

All dimensions in mm; 1 inch = 25.4 mm
Tolerances according: ISO 2768-m/EN 22768-m

Please visit www.schaffner.com to find more details on connectors.

Accessories

IL 13P IEC C13 Rewireable Connectors with Locking System



The locking system has a tensile force of typical 300N. It is recommended to use it with flange mount filters. For details refer to our Application Note "Using IEC Lock Power Cords with IEC Inlets and Filters".

Schaffner power connector with IEC lock guard against accidental disconnection of all electrical appliances with an IEC inlet. No exchange or modification of the IEC inlet or IEC inlet filter system is needed. Easy retrofit .for all electronic equipments and devices

[Technical Data Sheet >](#)

IL 13P IEC C13 Rewireable Angled Connectors with Locking System



- Protects appliances that are vulnerable to vibration
- Connector cannot be accidentally pulled or vibrated out of the inlet
- Space availability/constraints
- Different angles for ease of access
- Space saving
- Release locking mechanism
- Prevents accidental disconnection

[Technical Data Sheet >](#)

Power Cord with angled Locking System C13



- Protects appliances that are vulnerable to vibration
- Connector cannot be accidentally pulled or vibrated out of the inlet
- Space availability/constraints
- Different angles for ease of access
- Space saving
- Release locking mechanism
- Prevents accidental disconnection

[Technical Data Sheet >](#)