

EconoPIM™2 モジュール トレンチ/フィールドストップ IGBT4 and エミッターコントロール4 diode内蔵
and PressFIT / NTCサーミスタ

EconoPIM™2 module with Trench/Fieldstop IGBT4 and Emitter Controlled 4 diode and PressFIT / NTC

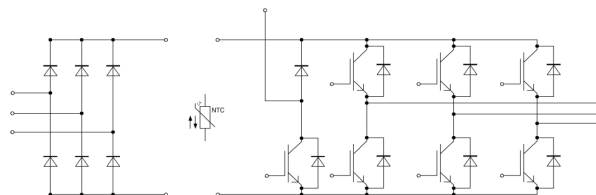
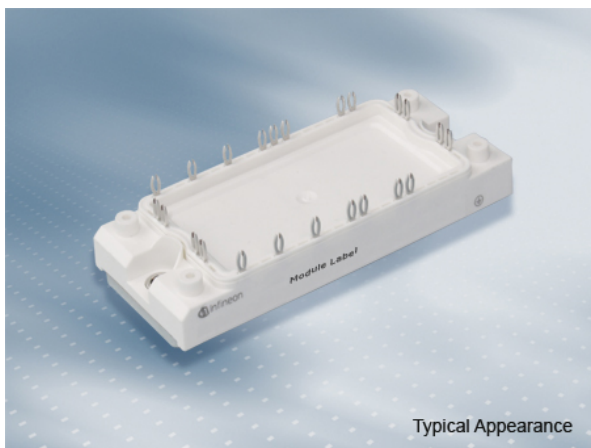

$V_{CES} = 1200V$

$I_{C\ nom} = 50A / I_{CRM} = 100A$

一般応用

- スタティックインバーター
- モーター駆動
- サーボ駆動

電気的特性

- 低スイッチング損失
- $T_{vj\ op} = 150^{\circ}C$
- 正温度特性を持った V_{CESat} 飽和電圧
- 低 V_{CESat} 飽和電圧

機械的特性

- 高いパワー/サーマルサイクル耐量
- 高いパワー密度
- 内蔵されたNTCサーミスタ
- 銅ベースプレート
- PressFIT 接合 技術
- 標準ハウジング

Typical Applications

- Auxiliary Inverters
- Motor Drives
- Servo Drives

Electrical Features

- Low Switching Losses
- $T_{vj\ op} = 150^{\circ}C$
- V_{CESat} with positive Temperature Coefficient
- Low V_{CESat}

Mechanical Features

- High Power and Thermal Cycling Capability
- High Power Density
- Integrated NTC temperature sensor
- Copper Base Plate
- PressFIT Contact Technology
- Standard Housing

Module Label Code

Barcode Code 128



DMX - Code



Content of the Code

| Content of the Code | Digit |
|----------------------------|---------|
| Module Serial Number | 1 - 5 |
| Module Material Number | 6 - 11 |
| Production Order Number | 12 - 19 |
| Datecode (Production Year) | 20 - 21 |
| Datecode (Production Week) | 22 - 23 |

| | | |
|-----------------|---------------------------------|----------------------|
| prepared by: AS | date of publication: 2013-10-16 | |
| approved by: RS | revision: 3.0 | UL approved (E83335) |



IGBT- インバータ / IGBT, Inverter
最大定格 / Maximum Rated Values

| | | | | |
|--|--|-------------------|-------|---|
| コレクタ・エミッタ間電圧 Collector-emitter voltage | $T_{vj} = 25^{\circ}\text{C}$ | V_{CES} | 1200 | V |
| 連続DCコレクタ電流 Continuous DC collector current | $T_C = 95^{\circ}\text{C}, T_{vj\max} = 175^{\circ}\text{C}$ | $I_{C\text{nom}}$ | 50 | A |
| 繰り返しピークコレクタ電流 Repetitive peak collector current | $t_P = 1\text{ms}$ | I_{CRM} | 100 | A |
| トータル損失 Total power dissipation | $T_C = 25^{\circ}\text{C}, T_{vj\max} = 175$ | P_{tot} | 280 | W |
| ゲート・エミッタ間ピーク電圧 Gate-emitter peak voltage | | V_{GES} | +/-20 | V |

電気的特性 / Characteristic Values

| | | | min. | typ. | max. | | |
|---|--|---|--------------------|----------------------|------|-------------|---|
| コレクタ・エミッタ間飽和電圧 Collector-emitter saturation voltage | $I_C = 50\text{A}, V_{GE} = 15\text{V}$ $I_C = 50\text{A}, V_{GE} = 15\text{V}$ $I_C = 50\text{A}, V_{GE} = 15\text{V}$ | $T_{vj} = 25^{\circ}\text{C}$ $T_{vj} = 125^{\circ}\text{C}$ $T_{vj} = 150^{\circ}\text{C}$ | $V_{CE\text{sat}}$ | 1,85 2,15 2,25 | 2,15 | V V V | |
| ゲート・エミッタ間しきい値電圧 Gate threshold voltage | $I_C = 1,70\text{mA}, V_{CE} = V_{GE}, T_{vj} = 25^{\circ}\text{C}$ | | V_{GEth} | 5,2 | 5,8 | 6,4 | V |
| ゲート電荷量 Gate charge | $V_{GE} = -15\text{V} \dots +15\text{V}$ | | Q_G | 0,38 | | | μC |
| 内蔵ゲート抵抗 Internal gate resistor | $T_{vj} = 25^{\circ}\text{C}$ | | R_{Gint} | 4,0 | | | Ω |
| 入力容量 Input capacitance | $f = 1\text{MHz}, T_{vj} = 25^{\circ}\text{C}, V_{CE} = 25\text{V}, V_{GE} = 0\text{V}$ | | C_{ies} | 2,80 | | | nF |
| 帰還容量 Reverse transfer capacitance | $f = 1\text{MHz}, T_{vj} = 25^{\circ}\text{C}, V_{CE} = 25\text{V}, V_{GE} = 0\text{V}$ | | C_{res} | 0,10 | | | nF |
| コレクタ・エミッタ間遮断電流 Collector-emitter cut-off current | $V_{CE} = 1200\text{V}, V_{GE} = 0\text{V}, T_{vj} = 25^{\circ}\text{C}$ | | I_{CES} | | | 1,0 | mA |
| ゲート・エミッタ間漏れ電流 Gate-emitter leakage current | $V_{CE} = 0\text{V}, V_{GE} = 20\text{V}, T_{vj} = 25^{\circ}\text{C}$ | | I_{GES} | | | 100 | nA |
| ターンオン遅れ時間 (誘導負荷) Turn-on delay time, inductive load | $I_C = 50\text{A}, V_{CE} = 600\text{V}$ $V_{GE} = \pm 15\text{V}$ $R_{Gon} = 15\Omega$ | $T_{vj} = 25^{\circ}\text{C}$ $T_{vj} = 125^{\circ}\text{C}$ $T_{vj} = 150^{\circ}\text{C}$ | t_{don} | 0,16 0,17 0,17 | | | μs μs μs |
| ターンオン上昇時間 (誘導負荷) Rise time, inductive load | $I_C = 50\text{A}, V_{CE} = 600\text{V}$ $V_{GE} = \pm 15\text{V}$ $R_{Gon} = 15\Omega$ | $T_{vj} = 25^{\circ}\text{C}$ $T_{vj} = 125^{\circ}\text{C}$ $T_{vj} = 150^{\circ}\text{C}$ | t_r | 0,03 0,04 0,04 | | | μs μs μs |
| ターンオフ遅れ時間 (誘導負荷) Turn-off delay time, inductive load | $I_C = 50\text{A}, V_{CE} = 600\text{V}$ $V_{GE} = \pm 15\text{V}$ $R_{Goff} = 15\Omega$ | $T_{vj} = 25^{\circ}\text{C}$ $T_{vj} = 125^{\circ}\text{C}$ $T_{vj} = 150^{\circ}\text{C}$ | t_{doff} | 0,33 0,43 0,45 | | | μs μs μs |
| ターンオフ下降時間 (誘導負荷) Fall time, inductive load | $I_C = 50\text{A}, V_{CE} = 600\text{V}$ $V_{GE} = \pm 15\text{V}$ $R_{Goff} = 15\Omega$ | $T_{vj} = 25^{\circ}\text{C}$ $T_{vj} = 125^{\circ}\text{C}$ $T_{vj} = 150^{\circ}\text{C}$ | t_f | 0,08 0,15 0,17 | | | μs μs μs |
| ターンオンスイッチング損失 Turn-on energy loss per pulse | $I_C = 50\text{A}, V_{CE} = 600\text{V}, L_S = 20\text{nH}$ $V_{GE} = \pm 15\text{V}, di/dt = 1400\text{A}/\mu\text{s} (T_{vj} = 150^{\circ}\text{C})$ $R_{Gon} = 15\Omega$ | $T_{vj} = 25^{\circ}\text{C}$ $T_{vj} = 125^{\circ}\text{C}$ $T_{vj} = 150^{\circ}\text{C}$ | E_{on} | 5,70 7,70 8,40 | | | mJ mJ mJ |
| ターンオフスイッチング損失 Turn-off energy loss per pulse | $I_C = 50\text{A}, V_{CE} = 600\text{V}, L_S = 20\text{nH}$ $V_{GE} = \pm 15\text{V}, du/dt = 3600\text{V}/\mu\text{s} (T_{vj} = 150^{\circ}\text{C})$ $R_{Goff} = 15\Omega$ | $T_{vj} = 25^{\circ}\text{C}$ $T_{vj} = 125^{\circ}\text{C}$ $T_{vj} = 150^{\circ}\text{C}$ | E_{off} | 2,80 4,30 4,80 | | | mJ mJ mJ |
| 短絡電流 SC data | $V_{GE} \leq 15\text{V}, V_{CC} = 800\text{V}$ $V_{CEmax} = V_{CES} - L_{SCE} \cdot di/dt$ $t_P \leq 10\mu\text{s}, T_{vj} = 150^{\circ}\text{C}$ | | I_{SC} | 180 | | | A |
| ジャンクション・ケース間熱抵抗 Thermal resistance, junction to case | IGBT部 (1素子当り) / per IGBT | | R_{thJC} | | 0,54 | | K/W |
| ケース・ヒートシンク間熱抵抗 Thermal resistance, case to heatsink | IGBT部 (1素子当り) / per IGBT $\lambda_{\text{Paste}} = 1\text{W}/(\text{m}\cdot\text{K})$ / $\lambda_{\text{grease}} = 1\text{W}/(\text{m}\cdot\text{K})$ | | R_{thCH} | 0,295 | | | K/W |
| 動作温度 Temperature under switching conditions | | | $T_{vj\text{op}}$ | -40 | 150 | | $^{\circ}\text{C}$ |

| | |
|-----------------|---------------------------------|
| prepared by: AS | date of publication: 2013-10-16 |
| approved by: RS | revision: 3.0 |



Diode、インバータ / Diode, Inverter
最大定格 / Maximum Rated Values

| | | | | |
|--|--|-----------|------|----------------------|
| ピーク繰返し逆電圧 Repetitive peak reverse voltage | $T_{vj} = 25^{\circ}\text{C}$ | V_{RRM} | 1200 | V |
| 連続DC電流 Continuous DC forward current | | I_F | 50 | A |
| ピーク繰返し順電流 Repetitive peak forward current | $t_P = 1\text{ ms}$ | I_{FRM} | 100 | A |
| 電流二乗時間積 I^2t - value | $V_R = 0\text{ V}, t_P = 10\text{ ms}, T_{vj} = 125^{\circ}\text{C}$ | I^2t | 560 | A^2s |

電気的特性 / Characteristic Values

| | | | min. | typ. | max. | |
|---|---|---|--------------------|----------------------|------|---|
| 順電圧 Forward voltage | $I_F = 50\text{ A}, V_{GE} = 0\text{ V}$ $I_F = 50\text{ A}, V_{GE} = 0\text{ V}$ $I_F = 50\text{ A}, V_{GE} = 0\text{ V}$ | $T_{vj} = 25^{\circ}\text{C}$ $T_{vj} = 125^{\circ}\text{C}$ $T_{vj} = 150^{\circ}\text{C}$ | V_F | 1,70 1,65 1,65 | 2,15 | V V V |
| ピーク逆回復電流 Peak reverse recovery current | $I_F = 50\text{ A}, -di_F/dt = 1400\text{ A}/\mu\text{s} (T_{vj}=150^{\circ}\text{C})$ $V_R = 600\text{ V}$ $V_{GE} = -15\text{ V}$ | $T_{vj} = 25^{\circ}\text{C}$ $T_{vj} = 125^{\circ}\text{C}$ $T_{vj} = 150^{\circ}\text{C}$ | I_{RM} | 54,0 60,0 63,0 | | A A A |
| 逆回復電荷量 Recovered charge | $I_F = 50\text{ A}, -di_F/dt = 1400\text{ A}/\mu\text{s} (T_{vj}=150^{\circ}\text{C})$ $V_R = 600\text{ V}$ $V_{GE} = -15\text{ V}$ | $T_{vj} = 25^{\circ}\text{C}$ $T_{vj} = 125^{\circ}\text{C}$ $T_{vj} = 150^{\circ}\text{C}$ | Q_r | 5,50 8,80 10,0 | | μC μC μC |
| 逆回復損失 Reverse recovery energy | $I_F = 50\text{ A}, -di_F/dt = 1400\text{ A}/\mu\text{s} (T_{vj}=150^{\circ}\text{C})$ $V_R = 600\text{ V}$ $V_{GE} = -15\text{ V}$ | $T_{vj} = 25^{\circ}\text{C}$ $T_{vj} = 125^{\circ}\text{C}$ $T_{vj} = 150^{\circ}\text{C}$ | E_{rec} | 1,70 3,00 3,70 | | mJ mJ mJ |
| ジャンクション・ケース間熱抵抗 Thermal resistance, junction to case | /Diode (1 素子当り) / per diode | | R_{thJC} | | 0,81 | K/W |
| ケース・ヒートシンク間熱抵抗 Thermal resistance, case to heatsink | /Diode (1 素子当り) / per diode $\lambda_{Paste} = 1\text{ W}/(\text{m}\cdot\text{K}) / \lambda_{grease} = 1\text{ W}/(\text{m}\cdot\text{K})$ | | R_{thCH} | | 0,44 | K/W |
| 動作温度 Temperature under switching conditions | | | $T_{vj\text{ op}}$ | -40 | 150 | $^{\circ}\text{C}$ |

Diode、整流器 / Diode, Rectifier
最大定格 / Maximum Rated Values

| | | | | |
|--|---|-------------|-------------|--|
| ピーク繰返し逆電圧 Repetitive peak reverse voltage | $T_{vj} = 25^{\circ}\text{C}$ | V_{RRM} | 1600 | V |
| 最大実効順電流/chip Maximum RMS forward current per chip | $T_C = 80^{\circ}\text{C}$ | I_{FRMSM} | 70 | A |
| 整流出力の最大実効電流 Maximum RMS current at rectifier output | $T_C = 80^{\circ}\text{C}$ | I_{RMSM} | 80 | A |
| サージ順電流 Surge forward current | $t_p = 10\text{ ms}, T_{vj} = 25^{\circ}\text{C}$ $t_p = 10\text{ ms}, T_{vj} = 150^{\circ}\text{C}$ | I_{FSM} | 450 370 | A A |
| 電流二乗時間積 I^2t - value | $t_p = 10\text{ ms}, T_{vj} = 25^{\circ}\text{C}$ $t_p = 10\text{ ms}, T_{vj} = 150^{\circ}\text{C}$ | I^2t | 1000 685 | A^2s A^2s |

電気的特性 / Characteristic Values

| | | | min. | typ. | max. | |
|---|---|-------|--------------------|------|-------|--------------------|
| 順電圧 Forward voltage | $T_{vj} = 150^{\circ}\text{C}, I_F = 50\text{ A}$ | V_F | | 1,05 | | V |
| 逆電流 Reverse current | $T_{vj} = 150^{\circ}\text{C}, V_R = 1600\text{ V}$ | I_R | | 1,00 | | mA |
| ジャンクション・ケース間熱抵抗 Thermal resistance, junction to case | /Diode (1 素子当り) / per diode | | R_{thJC} | | 0,85 | K/W |
| ケース・ヒートシンク間熱抵抗 Thermal resistance, case to heatsink | /Diode (1 素子当り) / per diode $\lambda_{Paste} = 1\text{ W}/(\text{m}\cdot\text{K}) / \lambda_{grease} = 1\text{ W}/(\text{m}\cdot\text{K})$ | | R_{thCH} | | 0,465 | K/W |
| 動作温度 Temperature under switching conditions | | | $T_{vj\text{ op}}$ | -40 | 150 | $^{\circ}\text{C}$ |

| | |
|-----------------|---------------------------------|
| prepared by: AS | date of publication: 2013-10-16 |
| approved by: RS | revision: 3.0 |



IGBT-ブレーキチョッパー / IGBT, Brake-Chopper
最大定格 / Maximum Rated Values

| | | | | |
|--|---|-------------------|-------|---|
| コレクタ・エミッタ間電圧 Collector-emitter voltage | $T_{vj} = 25^{\circ}\text{C}$ | V_{CES} | 1200 | V |
| 連続DCコレクタ電流 Continuous DC collector current | $T_C = 100^{\circ}\text{C}, T_{vj\max} = 175^{\circ}\text{C}$ | $I_{C\text{nom}}$ | 25 | A |
| 繰り返しピークコレクタ電流 Repetitive peak collector current | $t_P = 1\text{ms}$ | I_{CRM} | 50 | A |
| トータル損失 Total power dissipation | $T_C = 25^{\circ}\text{C}, T_{vj\max} = 175$ | P_{tot} | 160 | W |
| ゲート・エミッタ間ピーク電圧 Gate-emitter peak voltage | | V_{GES} | +/-20 | V |

電気的特性 / Characteristic Values

| | | | min. | typ. | max. | |
|---|---|---|--------------------|----------------------|------|---|
| コレクタ・エミッタ間飽和電圧 Collector-emitter saturation voltage | $I_C = 25\text{A}, V_{GE} = 15\text{V}$ $I_C = 25\text{A}, V_{GE} = 15\text{V}$ $I_C = 25\text{A}, V_{GE} = 15\text{V}$ | $T_{vj} = 25^{\circ}\text{C}$ $T_{vj} = 125^{\circ}\text{C}$ $T_{vj} = 150^{\circ}\text{C}$ | $V_{CE\text{sat}}$ | 1,85 2,15 2,25 | 2,15 | V V V |
| ゲート・エミッタ間しきい値電圧 Gate threshold voltage | $I_C = 0,85\text{mA}, V_{CE} = V_{GE}, T_{vj} = 25^{\circ}\text{C}$ | | V_{GEth} | 5,2 5,8 | 6,4 | V |
| ゲート電荷量 Gate charge | $V_{GE} = -15\text{V} \dots +15\text{V}$ | | Q_G | 0,20 | | μC |
| 内蔵ゲート抵抗 Internal gate resistor | $T_{vj} = 25^{\circ}\text{C}$ | | R_{Gint} | 0,0 | | Ω |
| 入力容量 Input capacitance | $f = 1\text{MHz}, T_{vj} = 25^{\circ}\text{C}, V_{CE} = 25\text{V}, V_{GE} = 0\text{V}$ | | C_{ies} | 1,45 | | nF |
| 帰還容量 Reverse transfer capacitance | $f = 1\text{MHz}, T_{vj} = 25^{\circ}\text{C}, V_{CE} = 25\text{V}, V_{GE} = 0\text{V}$ | | C_{res} | 0,05 | | nF |
| コレクタ・エミッタ間遮断電流 Collector-emitter cut-off current | $V_{CE} = 1200\text{V}, V_{GE} = 0\text{V}, T_{vj} = 25^{\circ}\text{C}$ | | I_{CES} | | 1,0 | mA |
| ゲート・エミッタ間漏れ電流 Gate-emitter leakage current | $V_{CE} = 0\text{V}, V_{GE} = 20\text{V}, T_{vj} = 25^{\circ}\text{C}$ | | I_{GES} | | 100 | nA |
| ターンオン遅れ時間 (誘導負荷) Turn-on delay time, inductive load | $I_C = 25\text{A}, V_{CE} = 600\text{V}$ $V_{GE} = \pm 15\text{V}$ $R_{Gon} = 37\Omega$ | $T_{vj} = 25^{\circ}\text{C}$ $T_{vj} = 125^{\circ}\text{C}$ $T_{vj} = 150^{\circ}\text{C}$ | t_{don} | 0,05 0,06 0,06 | | μs μs μs |
| ターンオン上昇時間 (誘導負荷) Rise time, inductive load | $I_C = 25\text{A}, V_{CE} = 600\text{V}$ $V_{GE} = \pm 15\text{V}$ $R_{Gon} = 37\Omega$ | $T_{vj} = 25^{\circ}\text{C}$ $T_{vj} = 125^{\circ}\text{C}$ $T_{vj} = 150^{\circ}\text{C}$ | t_r | 0,03 0,04 0,05 | | μs μs μs |
| ターンオフ遅れ時間 (誘導負荷) Turn-off delay time, inductive load | $I_C = 25\text{A}, V_{CE} = 600\text{V}$ $V_{GE} = \pm 15\text{V}$ $R_{Goff} = 37\Omega$ | $T_{vj} = 25^{\circ}\text{C}$ $T_{vj} = 125^{\circ}\text{C}$ $T_{vj} = 150^{\circ}\text{C}$ | t_{doff} | 0,34 0,43 0,45 | | μs μs μs |
| ターンオフ下降時間 (誘導負荷) Fall time, inductive load | $I_C = 25\text{A}, V_{CE} = 600\text{V}$ $V_{GE} = \pm 15\text{V}$ $R_{Goff} = 37\Omega$ | $T_{vj} = 25^{\circ}\text{C}$ $T_{vj} = 125^{\circ}\text{C}$ $T_{vj} = 150^{\circ}\text{C}$ | t_f | 0,05 0,07 0,08 | | μs μs μs |
| ターンオンスイッチング損失 Turn-on energy loss per pulse | $I_C = 25\text{A}, V_{CE} = 600\text{V}, L_S = 20\text{nH}$ $V_{GE} = \pm 15\text{V}$ $R_{Gon} = 37\Omega$ | $T_{vj} = 25^{\circ}\text{C}$ $T_{vj} = 125^{\circ}\text{C}$ $T_{vj} = 150^{\circ}\text{C}$ | E_{on} | 2,00 2,65 2,90 | | mJ mJ mJ |
| ターンオフスイッチング損失 Turn-off energy loss per pulse | $I_C = 25\text{A}, V_{CE} = 600\text{V}, L_S = 20\text{nH}$ $V_{GE} = \pm 15\text{V}$ $R_{Goff} = 37\Omega$ | $T_{vj} = 25^{\circ}\text{C}$ $T_{vj} = 125^{\circ}\text{C}$ $T_{vj} = 150^{\circ}\text{C}$ | E_{off} | 1,40 2,20 2,40 | | mJ mJ mJ |
| 短絡電流 SC data | $V_{GE} \leq 15\text{V}, V_{CC} = 800\text{V}$ $V_{CE\text{max}} = V_{CES} - L_{SCE} \cdot di/dt$ $t_P \leq 10\mu\text{s}, T_{vj} = 150^{\circ}\text{C}$ | | I_{SC} | 90 | | A |
| ジャンクション・ケース間熱抵抗 Thermal resistance, junction to case | IGBT部 (1素子当り) / per IGBT | | R_{thJC} | | 0,95 | K/W |
| ケース・ヒートシンク間熱抵抗 Thermal resistance, case to heatsink | IGBT部 (1素子当り) / per IGBT $\lambda_{\text{Paste}} = 1\text{W}/(\text{m}\cdot\text{K})$ / $\lambda_{\text{grease}} = 1\text{W}/(\text{m}\cdot\text{K})$ | | R_{thCH} | | 0,52 | K/W |
| 動作温度 Temperature under switching conditions | | | $T_{vj\text{op}}$ | -40 | 150 | $^{\circ}\text{C}$ |

| | |
|-----------------|---------------------------------|
| prepared by: AS | date of publication: 2013-10-16 |
| approved by: RS | revision: 3.0 |



Diode、ブレーキチョッパー / Diode, Brake-Chopper
最大定格 / Maximum Rated Values

| | | | | |
|--|--|-----------|------|------------------|
| ピーク繰返し逆電圧 Repetitive peak reverse voltage | $T_{vj} = 25^{\circ}\text{C}$ | V_{RRM} | 1200 | V |
| 連続DC電流 Continuous DC forward current | | I_F | 15 | A |
| ピーク繰返し順電流 Repetitive peak forward current | $t_P = 1\text{ ms}$ | I_{FRM} | 30 | A |
| 電流二乗時間積 I^2t - value | $V_R = 0\text{ V}, t_P = 10\text{ ms}, T_{vj} = 125^{\circ}\text{C}$ | I^2t | 48,0 | A ² s |

電気的特性 / Characteristic Values

| | | | min. | typ. | max. | |
|---|---|---|--------------------|----------------------|------|---|
| 順電圧 Forward voltage | $I_F = 15\text{ A}, V_{GE} = 0\text{ V}$ $I_F = 15\text{ A}, V_{GE} = 0\text{ V}$ $I_F = 15\text{ A}, V_{GE} = 0\text{ V}$ | $T_{vj} = 25^{\circ}\text{C}$ $T_{vj} = 125^{\circ}\text{C}$ $T_{vj} = 150^{\circ}\text{C}$ | V_F | 1,75 1,75 1,75 | 2,15 | V V V |
| ピーク逆回復電流 Peak reverse recovery current | $I_F = 15\text{ A}, -di_F/dt = 1000\text{ A}/\mu\text{s} (T_{vj}=150^{\circ}\text{C})$ $V_R = 600\text{ V}$ | $T_{vj} = 25^{\circ}\text{C}$ $T_{vj} = 125^{\circ}\text{C}$ $T_{vj} = 150^{\circ}\text{C}$ | I_{RM} | 20,0 22,0 23,0 | | A A A |
| 逆回復電荷量 Recovered charge | $I_F = 15\text{ A}, -di_F/dt = 1000\text{ A}/\mu\text{s} (T_{vj}=150^{\circ}\text{C})$ $V_R = 600\text{ V}$ | $T_{vj} = 25^{\circ}\text{C}$ $T_{vj} = 125^{\circ}\text{C}$ $T_{vj} = 150^{\circ}\text{C}$ | Q_r | 1,50 2,50 2,70 | | μC μC μC |
| 逆回復損失 Reverse recovery energy | $I_F = 15\text{ A}, -di_F/dt = 1000\text{ A}/\mu\text{s} (T_{vj}=150^{\circ}\text{C})$ $V_R = 600\text{ V}$ | $T_{vj} = 25^{\circ}\text{C}$ $T_{vj} = 125^{\circ}\text{C}$ $T_{vj} = 150^{\circ}\text{C}$ | E_{rec} | 0,55 0,90 1,00 | | mJ mJ mJ |
| ジャンクション・ケース間熱抵抗 Thermal resistance, junction to case | /Diode (1 素子当り) / per diode | | R_{thJC} | | 1,50 | K/W |
| ケース・ヒートシンク間熱抵抗 Thermal resistance, case to heatsink | /Diode (1 素子当り) / per diode $\lambda_{Paste} = 1\text{ W}/(\text{m}\cdot\text{K}) / \lambda_{grease} = 1\text{ W}/(\text{m}\cdot\text{K})$ | | R_{thCH} | 0,82 | | K/W |
| 動作温度 Temperature under switching conditions | | | $T_{vj\text{ op}}$ | -40 | 150 | $^{\circ}\text{C}$ |

NTC-サーミスタ / NTC-Thermistor

電気的特性 / Characteristic Values

| | | | min. | typ. | max. | |
|------------------------------|---|--|--------------|------|------|------------|
| 定格抵抗値 Rated resistance | $T_C = 25^{\circ}\text{C}$ | | R_{25} | 5,00 | | k Ω |
| R100の偏差 Deviation of R100 | $T_C = 100^{\circ}\text{C}, R_{100} = 493\ \Omega$ | | $\Delta R/R$ | -5 | 5 | % |
| 損失 Power dissipation | $T_C = 25^{\circ}\text{C}$ | | P_{25} | | 20,0 | mW |
| B-定数 B-value | $R_2 = R_{25} \exp [B_{25/50}(1/T_2 - 1/(298,15\text{ K}))]$ | | $B_{25/50}$ | 3375 | | K |
| B-定数 B-value | $R_2 = R_{25} \exp [B_{25/80}(1/T_2 - 1/(298,15\text{ K}))]$ | | $B_{25/80}$ | 3411 | | K |
| B-定数 B-value | $R_2 = R_{25} \exp [B_{25/100}(1/T_2 - 1/(298,15\text{ K}))]$ | | $B_{25/100}$ | 3433 | | K |

適切なアプリケーションノートによる仕様
Specification according to the valid application note.

| | |
|-----------------|---------------------------------|
| prepared by: AS | date of publication: 2013-10-16 |
| approved by: RS | revision: 3.0 |



モジュール / Module

| | | | | | |
|---|---|--|--------------------------------|------|------------------|
| 絶縁耐圧 Isolation test voltage | RMS, f = 50 Hz, t = 1 min. | V _{ISOL} | 2,5 | | kV |
| ベースプレート材質 Material of module baseplate | | | Cu | | |
| 内部絶縁 Internal isolation | 基礎絶縁 (クラス1, IEC 61140) basic insulation (class 1, IEC 61140) | | Al ₂ O ₃ | | |
| 沿面距離 Creepage distance | 連絡方法 - ヒートシンク / terminal to heatsink 連絡方法 - 連絡方法 / terminal to terminal | | 10,0 | | mm |
| 空間距離 Clearance | 連絡方法 - ヒートシンク / terminal to heatsink 連絡方法 - 連絡方法 / terminal to terminal | | 7,5 | | mm |
| 相対トラッキング指数 Comperative tracking index | | CTI | > 200 | | |
| | | | min. | typ. | max. |
| ケース・ヒートシンク間熱抵抗 Thermal resistance, case to heatsink | /モジュール / per module $\lambda_{\text{Paste}} = 1 \text{ W/(m}\cdot\text{K)} / \lambda_{\text{grease}} = 1 \text{ W/(m}\cdot\text{K)}$ | R _{thCH} | 0,02 | | K/W |
| 内部インダクタンス Stray inductance module | | L _{sCE} | 35 | | nH |
| パワーターミナル・チップ間抵抗 Module lead resistance, terminals - chip | T _c = 25°C, /スイッチ / per switch | R _{CC+EE'} R _{AA+CC'} | 4,00 3,00 | | mΩ |
| 最大ジャンクション温度 Maximum junction temperature | インバータ、ブレーキチョッパー / inverter, brake-chopper 整流器 / rectifier | T _{vj max} | | | 175 °C 150 °C |
| 動作温度 Temperature under switching conditions | インバータ、ブレーキチョッパー / inverter, brake-chopper 整流器 / rectifier | T _{vj op} | -40 -40 | | 150 °C 150 °C |
| 保存温度 Storage temperature | | T _{stg} | -40 | | 125 °C |
| 取り付けネジ締め付けトルク Mounting torque for modul mounting | 取り付けネジ M5 適切なアプリケーションノートによるマウンティング Screw M5 - Mounting according to valid application note | M | 3,00 | - | 6,00 Nm |
| 質量 Weight | | G | | 180 | g |

| | |
|-----------------|---------------------------------|
| prepared by: AS | date of publication: 2013-10-16 |
| approved by: RS | revision: 3.0 |



出力特性 IGBT- インバータ (Typical)
output characteristic IGBT, Inverter (typical)

$I_C = f(V_{CE})$
 $V_{GE} = 15\text{ V}$

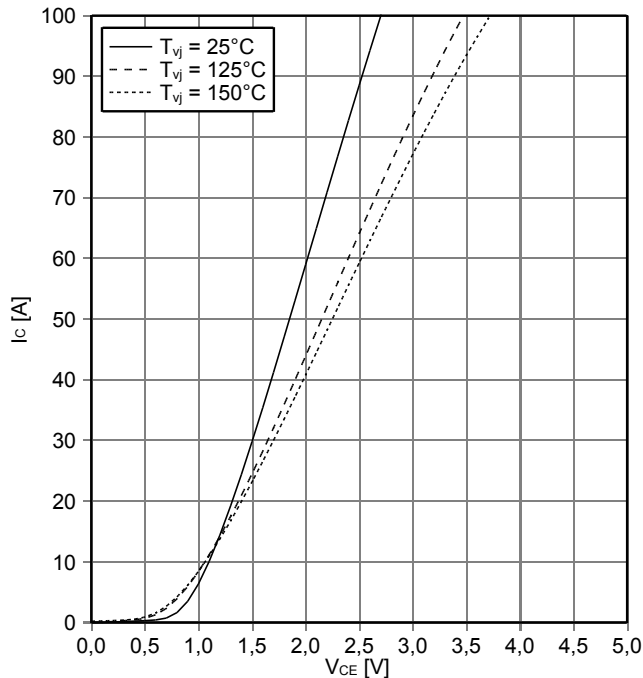

出力特性 IGBT- インバータ (Typical)
output characteristic IGBT, Inverter (typical)

$I_C = f(V_{CE})$
 $T_{vj} = 150^\circ\text{C}$

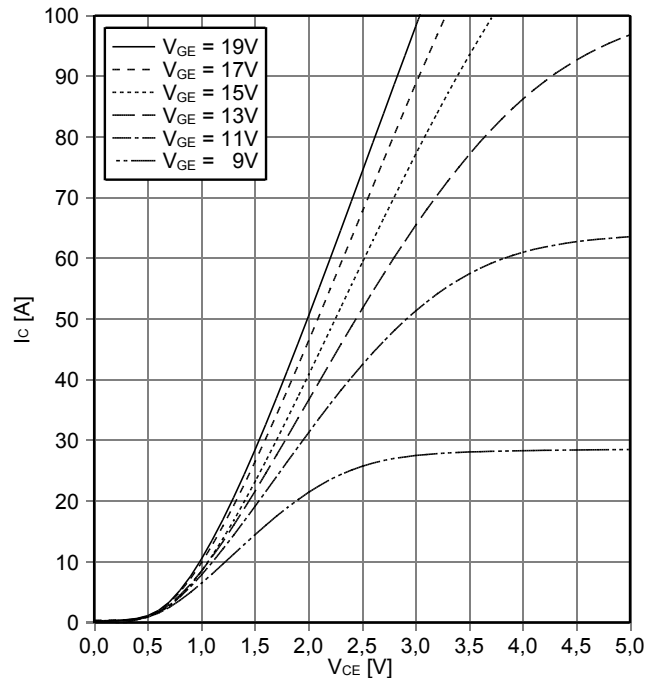

伝達特性 IGBT- インバータ (Typical)
transfer characteristic IGBT, Inverter (typical)

$I_C = f(V_{GE})$
 $V_{CE} = 20\text{ V}$

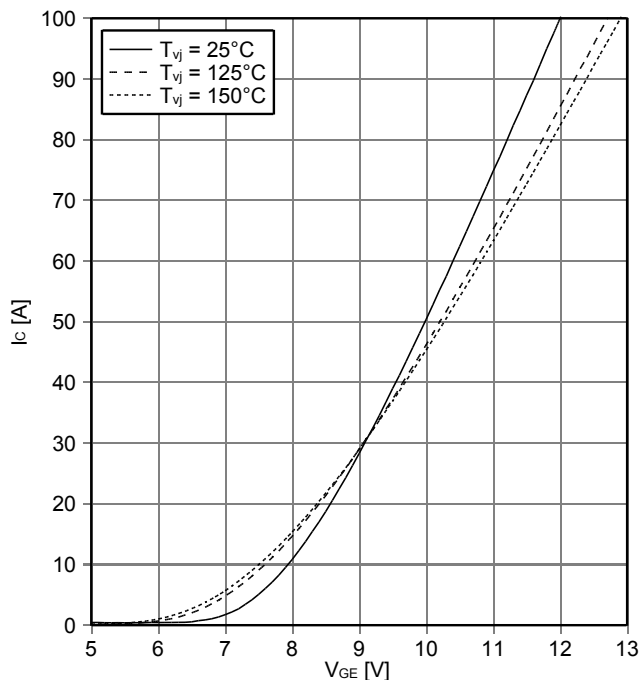

スイッチング損失 IGBT- インバータ (Typical)
switching losses IGBT, Inverter (typical)

$E_{on} = f(I_C), E_{off} = f(I_C)$
 $V_{GE} = \pm 15\text{ V}, R_{Gon} = 15\ \Omega, R_{Goff} = 15\ \Omega, V_{CE} = 600\text{ V}$

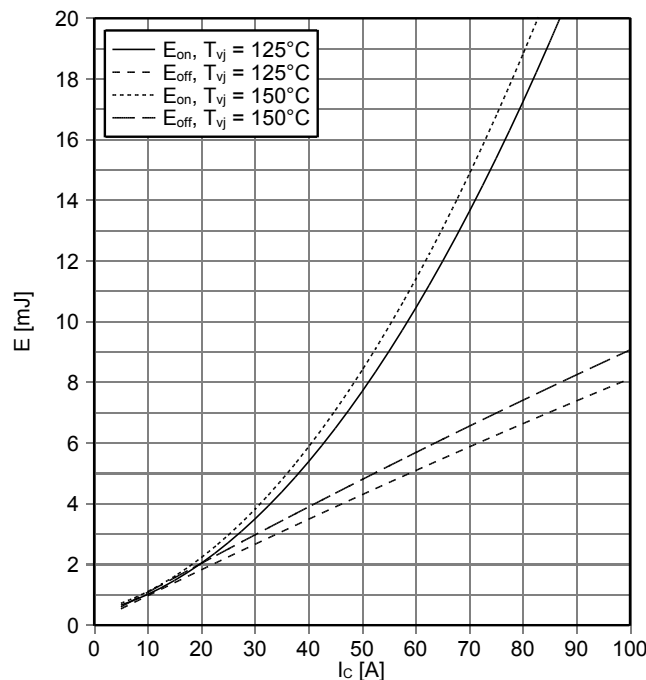

| | |
|-----------------|---------------------------------|
| prepared by: AS | date of publication: 2013-10-16 |
| approved by: RS | revision: 3.0 |



スイッチング損失 IGBT- インバータ (Typical)
switching losses IGBT, Inverter (typical)

$E_{on} = f(R_G)$, $E_{off} = f(R_G)$
 $V_{GE} = \pm 15\text{ V}$, $I_C = 50\text{ A}$, $V_{CE} = 600\text{ V}$

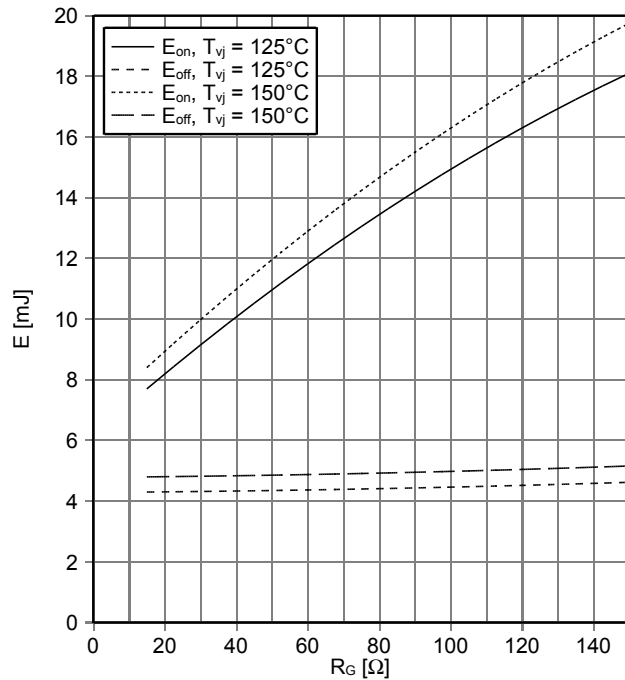

過渡熱インピーダンス IGBT- インバータ
transient thermal impedance IGBT, Inverter

$Z_{thJC} = f(t)$

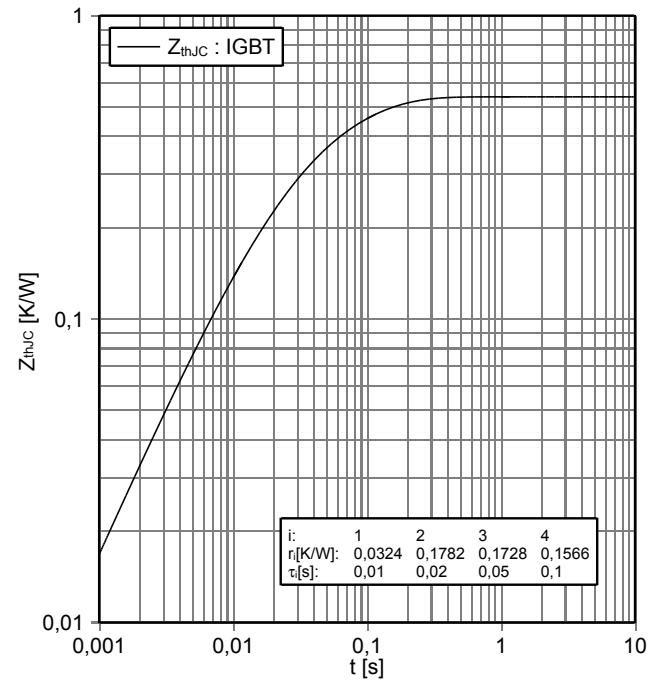

逆バイアス安全動作領域 IGBT- インバータ (RBSOA)
reverse bias safe operating area IGBT, Inverter (RBSOA)

$I_C = f(V_{CE})$
 $V_{GE} = \pm 15\text{ V}$, $R_{Goff} = 15\ \Omega$, $T_{vj} = 150^\circ\text{C}$

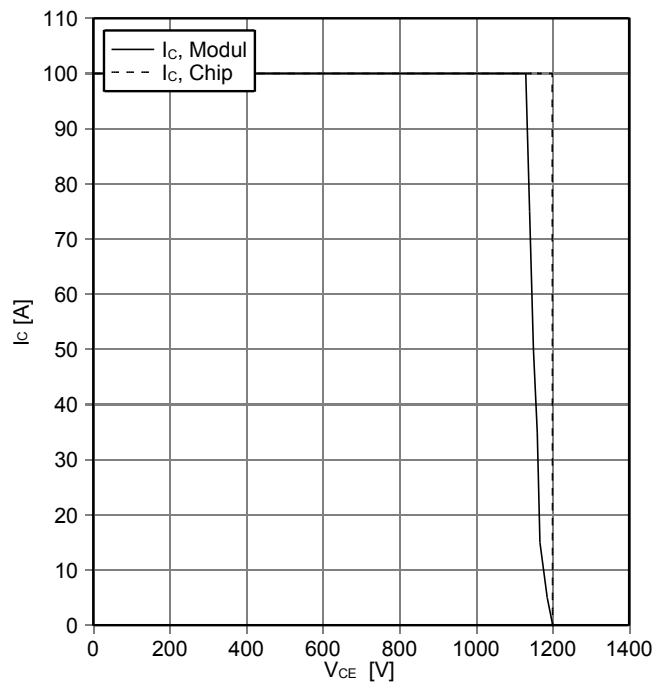

順電圧特性 Diode、インバータ (typical)
forward characteristic of Diode, Inverter (typical)

$I_F = f(V_F)$

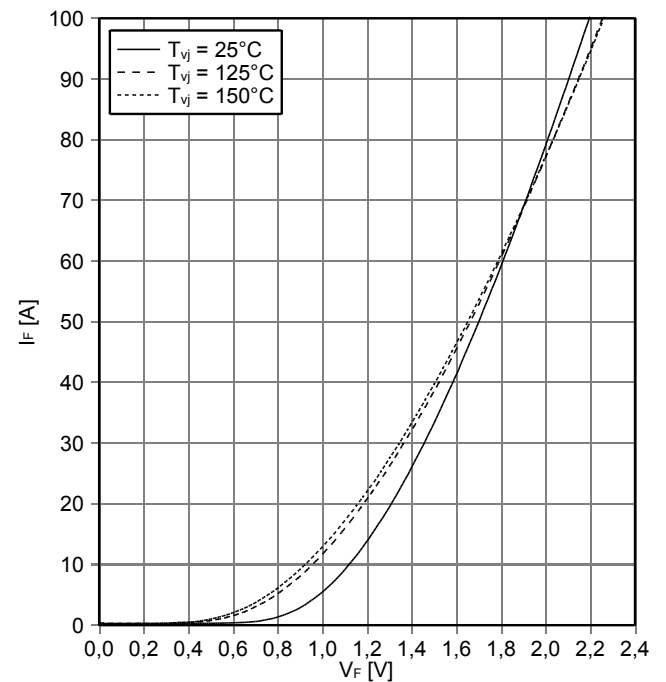

| | |
|-----------------|---------------------------------|
| prepared by: AS | date of publication: 2013-10-16 |
| approved by: RS | revision: 3.0 |



スイッチング損失 Diode、インバータ (Typical)
switching losses Diode, Inverter (typical)

$E_{rec} = f(I_F)$
 $R_{Gon} = 15 \Omega, V_{CE} = 600 V$

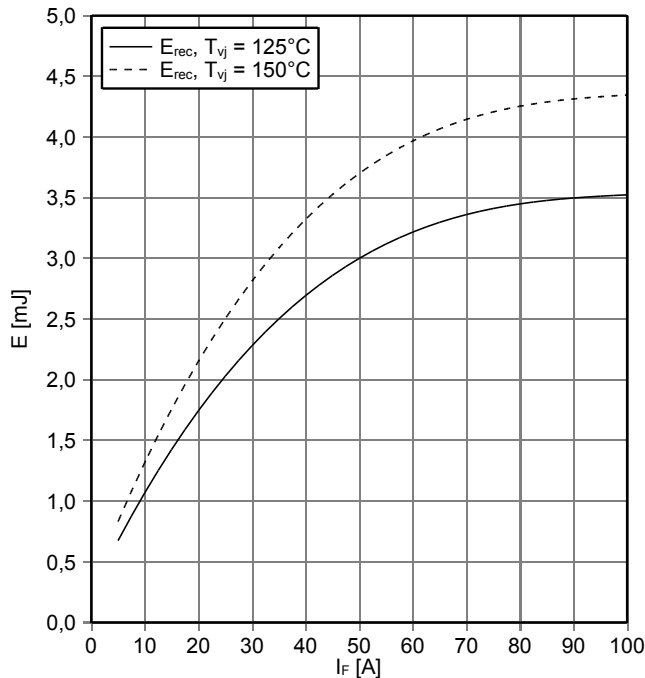

スイッチング損失 Diode、インバータ (Typical)
switching losses Diode, Inverter (typical)

$E_{rec} = f(R_G)$
 $I_F = 50 A, V_{CE} = 600 V$

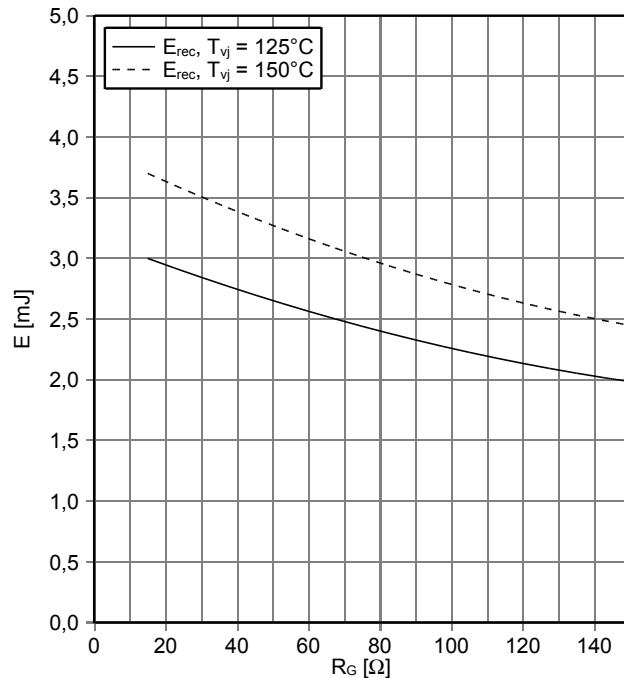

過渡熱インピーダンス Diode、インバータ
transient thermal impedance Diode, Inverter

$Z_{thJC} = f(t)$

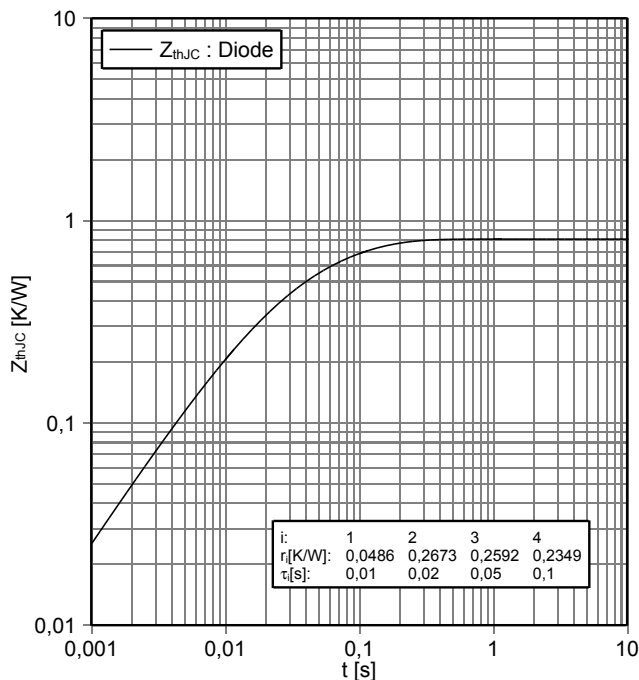

順方向特性 Diode、整流器 (典型)
forward characteristic of Diode, Rectifier (typical)

$I_F = f(V_F)$

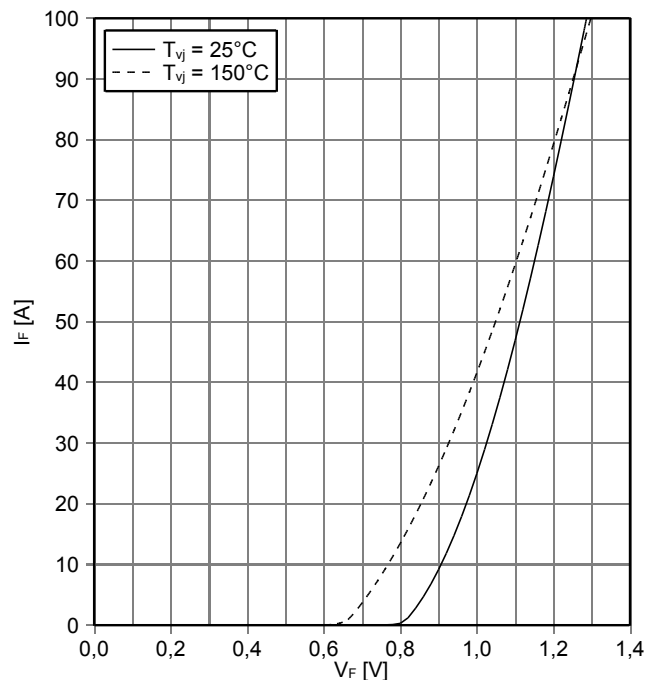

| | |
|-----------------|---------------------------------|
| prepared by: AS | date of publication: 2013-10-16 |
| approved by: RS | revision: 3.0 |



出力特性 IGBT-ブレーキチョッパー (Typical)
output characteristic IGBT, Brake-Chopper (typical)

$I_C = f(V_{CE})$
 $V_{GE} = 15\text{ V}$

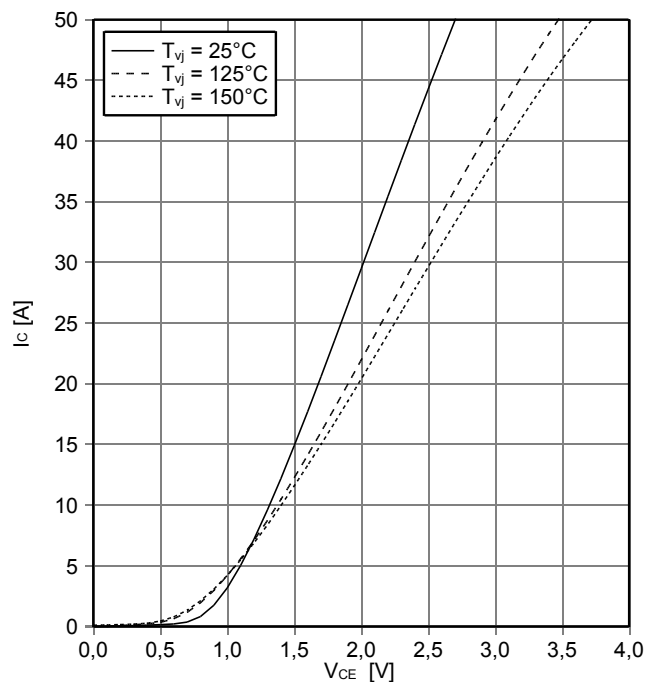

順電圧特性 Diode、ブレーキチョッパー (typical)
forward characteristic of Diode, Brake-Chopper (typical)

$I_F = f(V_F)$

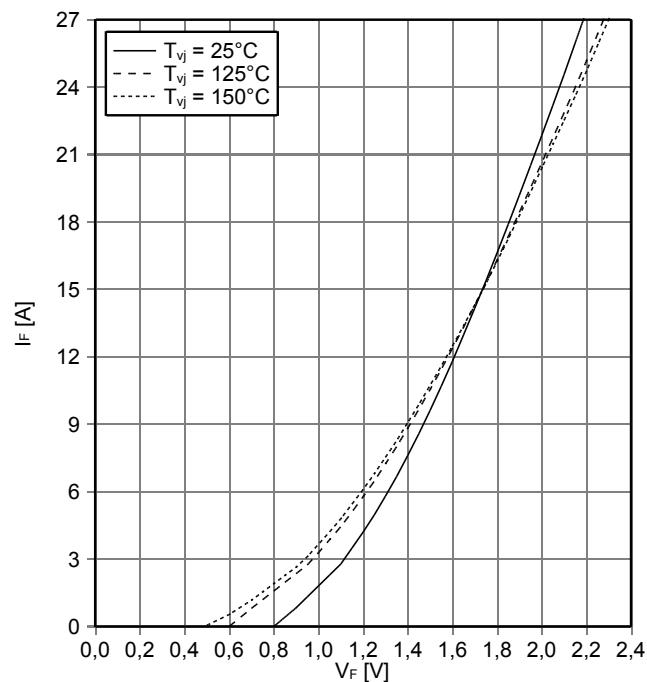

NTC-サーミスタ サーミスタの温度特性
NTC-Thermistor-temperature characteristic (typical)

$R = f(T)$

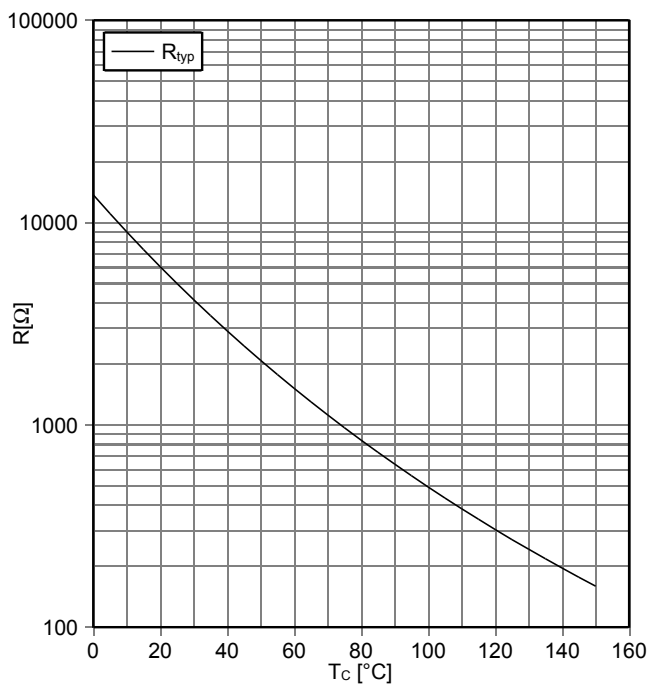

| | |
|-----------------|---------------------------------|
| prepared by: AS | date of publication: 2013-10-16 |
| approved by: RS | revision: 3.0 |

回路図 / circuit_diagram_headline

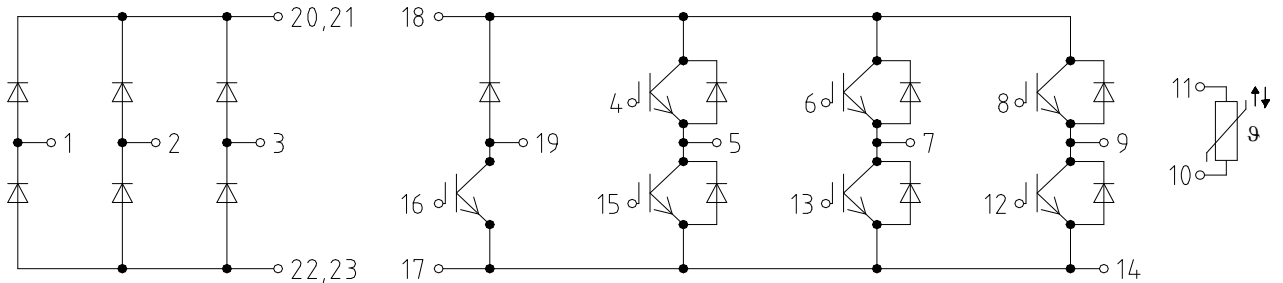

パッケージ概要 / package outlines

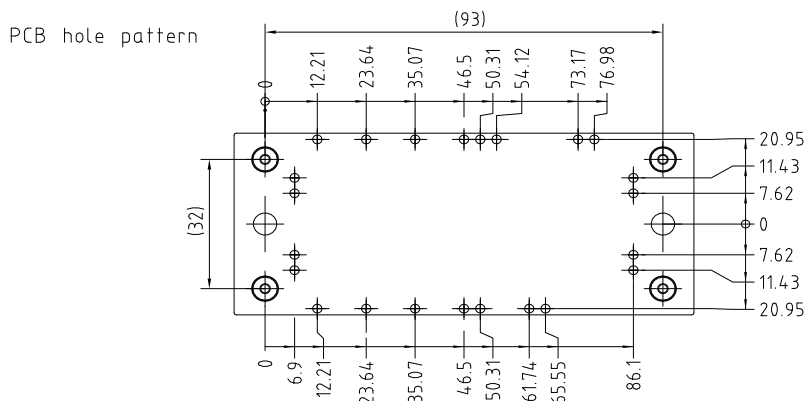
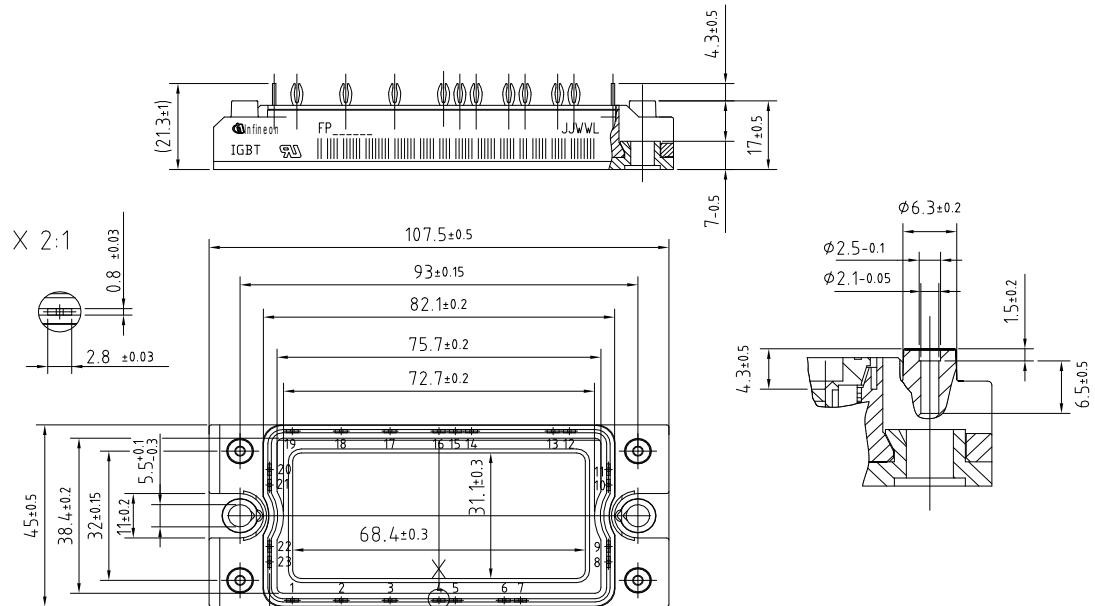

- Tolerance of PCB hole pattern ± 0.1
- hole specifications see AN 2007-09
- Diameters of plated holes ϕ 2.14mm - 2.29mm
- Diameter of drill ϕ 2.35mm

| | |
|-----------------|---------------------------------|
| prepared by: AS | date of publication: 2013-10-16 |
| approved by: RS | revision: 3.0 |