

UM11334

FRDMDUAL33664EVB evaluation board

Rev. 1 — 15 January 2020

User guide

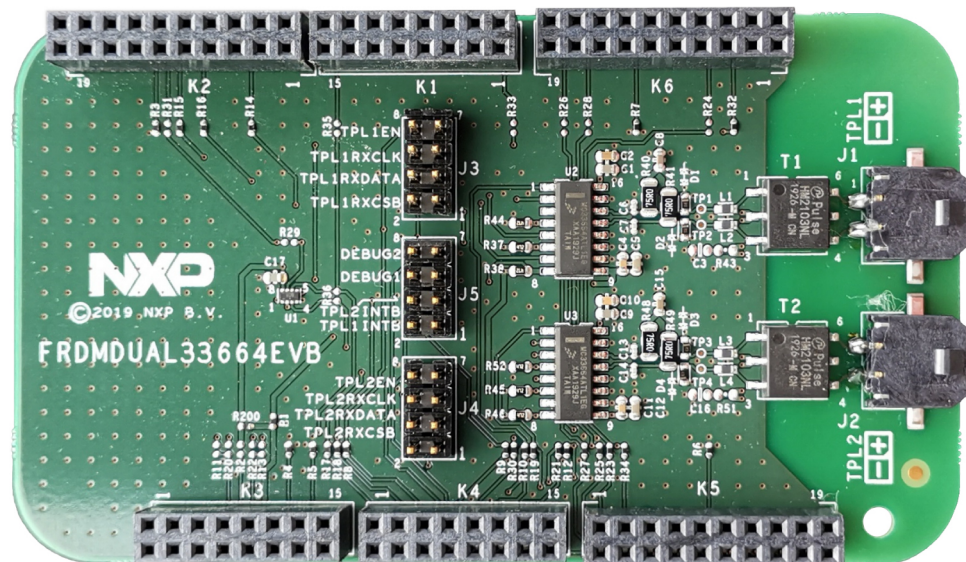

aaa-036222

Important Notice

NXP provides the enclosed product(s) under the following conditions:

This evaluation kit is intended for use of ENGINEERING DEVELOPMENT OR EVALUATION PURPOSES ONLY. It is provided as a sample IC pre-soldered to a printed circuit board to make it easier to access inputs, outputs, and supply terminals. This evaluation board may be used with any development system or other source of I/O signals by simply connecting it to the host MCU or computer board via off-the-shelf cables. This evaluation board is not a Reference Design and is not intended to represent a final design recommendation for any particular application. Final device in an application will be heavily dependent on proper printed circuit board layout and heat sinking design as well as attention to supply filtering, transient suppression, and I/O signal quality.

The goods provided may not be complete in terms of required design, marketing, and or manufacturing related protective considerations, including product safety measures typically found in the end product incorporating the goods. Due to the open construction of the product, it is the user's responsibility to take any and all appropriate precautions with regard to electrostatic discharge. In order to minimize risks associated with the customers applications, adequate design and operating safeguards must be provided by the customer to minimize inherent or procedural hazards. For any safety concerns, contact NXP sales and technical support services.

Should this evaluation kit not meet the specifications indicated in the kit, it may be returned within 30 days from the date of delivery and will be replaced by a new kit.

NXP reserves the right to make changes without further notice to any products herein. NXP makes no warranty, representation or guarantee regarding the suitability of its products for any particular purpose, nor does NXP assume any liability arising out of the application or use of any product or circuit, and specifically disclaims any and all liability, including without limitation consequential or incidental damages. Typical parameters can and do vary in different applications and actual performance may vary over time. All operating parameters, including Typical, must be validated for each customer application by customer's technical experts.

NXP does not convey any license under its patent rights nor the rights of others. NXP products are not designed, intended, or authorized for use as components in systems intended for surgical implant into the body, or other applications intended to support or sustain life, or for any other application in which the failure of the NXP product could create a situation where personal injury or death may occur.

Should the Buyer purchase or use NXP products for any such unintended or unauthorized application, the Buyer shall indemnify and hold NXP and its officers, employees, subsidiaries, affiliates, and distributors harmless against all claims, costs, damages, and expenses, and reasonable attorney fees arising out of, directly or indirectly, any claim of personal injury or death associated with such unintended or unauthorized use, even if such claim alleges NXP was negligent regarding the design or manufacture of the part.



1 Introduction

This document is the user guide for the FRDMDUAL33664EVB evaluation board. This document is intended for the engineers involved in the evaluation, design, implementation, and validation of MC33664, Isolated network high-speed transceiver.

The scope of this document is to provide the user with information to evaluate the MC33664, Isolated network high-speed transceiver. This document covers connecting the hardware, installing the software and tools, configuring the environment and using the kit.

2 Finding kit resources and information on the NXP web site

NXP Semiconductors provides online resources for this evaluation board and its supported device(s) on <http://www.nxp.com>.

The information page for FRDMDUAL33664EVB evaluation board is at <http://www.nxp.com/FRDMDUAL33664EVB>. The information page provides overview information, documentation, software and tools, parametrics, ordering information and a **Getting Started** tab. The **Getting Started** tab provides quick-reference information applicable to using the FRDMDUAL33664EVB evaluation board, including the downloadable assets referenced in this document.

2.1 Collaborate in the NXP community

The NXP community is for sharing ideas and tips, ask and answer technical questions, and receive input on just about any embedded design topic.

The NXP community is at <http://community.nxp.com>.

3 Getting ready

Working with the FRDMDUAL33664EVB requires the kit contents, additional hardware, and software, depending on the use case.

3.1 Kit contents

- Assembled and tested evaluation board in an anti-static bag
- 20 cm TPL bus cable
- Quick start guide

3.2 Additional hardware

- Use with the S32K144 EVB (recommended)
- Use with other microcontroller platform (requires breadboard design)
- Use as standalone EVB, requires 5.0 V, 200 mA power supply (optional 3.3 V power supply 200 mA) and signal stimulation with signal generator

4 Getting to know the hardware

4.1 Kit overview

The FRDMDUAL33664EVB is a hardware tool for evaluation and development and is ideal for rapid prototyping of an isolated network high-speed transceiver. It can be used to evaluate the features of the MC33664A device.

The evaluation board allows the user to connect SPI signals from the MCU to the device SPI_TX and be able to create bit pulses transmission to the bus through the transformer. The messages received by the device can be converted bit by bit and transferred to the MCU by SPI.

4.1.1 FRDMDUAL33664EVB features

- Two MC33664ATL1EG isolated communication transceiver in a 16-pin SOICN package
- Isolated communication by transformers with connector
- Single TPL chain interface (requires two SPIs)
- Dual TPL chain interface (requires three SPIs)
- Compatible to S32K144EVB-Q100

Note: The FRDMDUAL33664EVB does not support the Fault line feature.

4.2 Kit featured components

Figure 1 identifies important components on the board and Table 1 provides additional details on these components.

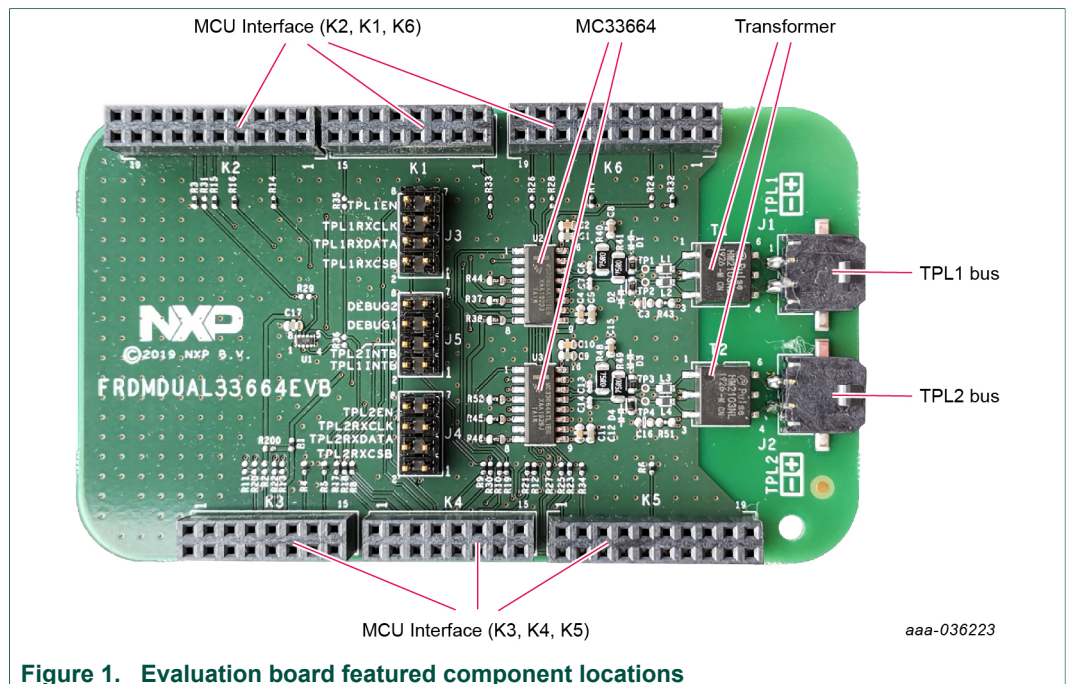

Figure 1. Evaluation board featured component locations

Table 1. Evaluation board component descriptions

Name	Description
MCU interface (K2, K1, K6)	Interface pin for microcontroller development platform (recommended S32K144-EVB)
MC33664	Isolated network high-speed transceiver
Transformer	Bus isolator transformer (T1, T2)
TPL1 bus	TPL1 bus interface
TPL2 bus	TPL2 bus interface
MCU interface (K3, K4, K5)	Interface pin for microcontroller development platform (recommended S32K144-EVB)

4.2.1 MC33664: Isolated network high-speed transceiver

4.2.1.1 General description

The MC33664 is a SMARTMOS transceiver physical layer transformer driver designed to interface a microcontroller conveniently to a high speed isolated communication network. MCU serial peripheral interface (SPI) data bits are directly converted to pulse bit information and transferred to the bus network.

Slave response messages use the same structure to send pulse bit information to the MC33664, which is converted and sent back to the MCU as a SPI bit stream.

4.2.1.2 Block diagram

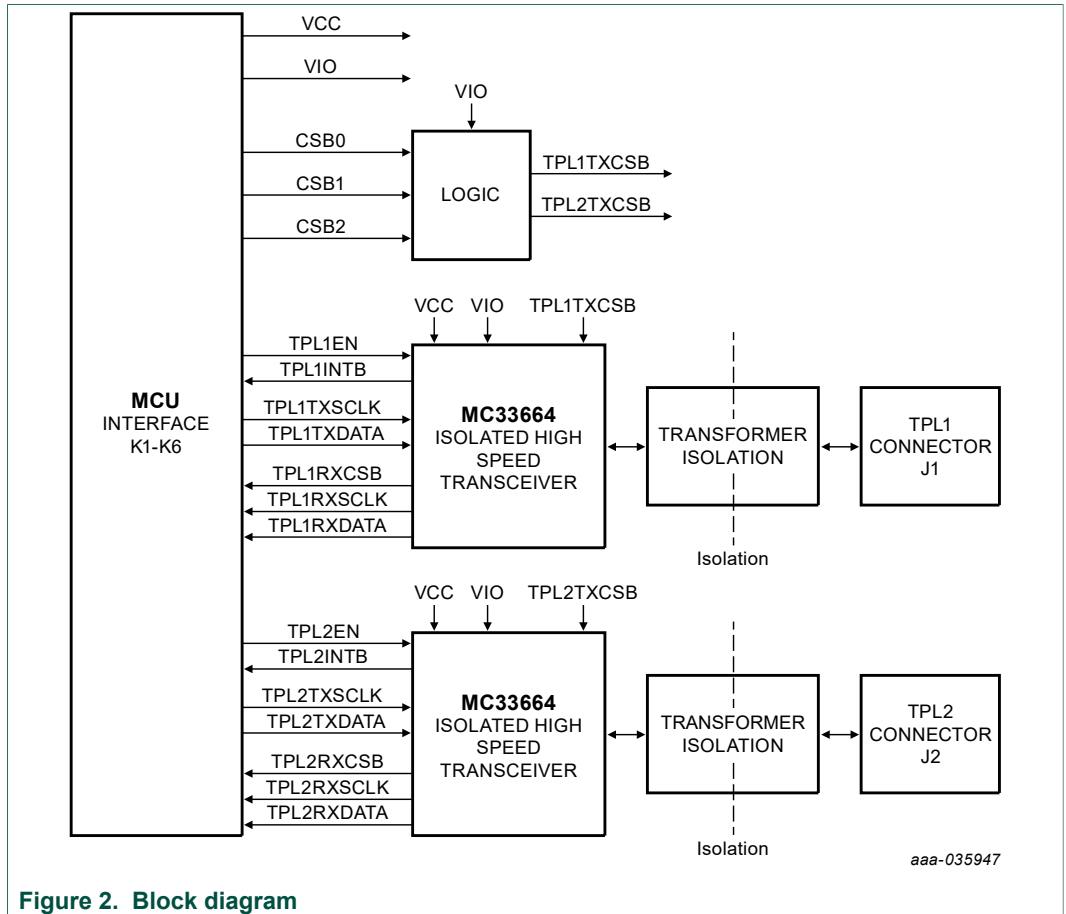

Figure 2. Block diagram

4.2.1.3 Features

- 2.0 Mbit/s isolated network communication rate
- Dual SPI architecture for message confirmation
- Robust conducted and radiated immunity with wake-up
- 3.3 V and 5.0 V compatible logic thresholds
- Low sleep mode current with automatic bus wake-up
- Ultra-low radiated emissions

4.2.1.4 Modes of operation

The modes of operation followed by MC33664 for the VIO and EN pins are shown in [Table 2](#).

Table 2. Modes of operation

Device mode	EN pin	VIO pin	LED pin	Comment
Normal	1	1	On	The MC33664 operates as a full transceiver. MCU messages transmitted on the SPI_TX emerge on the SPI_RX for the MCU to read.
Sleep	0	1	Off	In Sleep mode, the transceiver activates the INTB pin when a valid wake-up sequence is detected. The INTB pin remains low until the rising edge of the EN pin places the device in Normal mode.

4.2.2 Connectors

Figure 3 shows the location of connectors on the board.

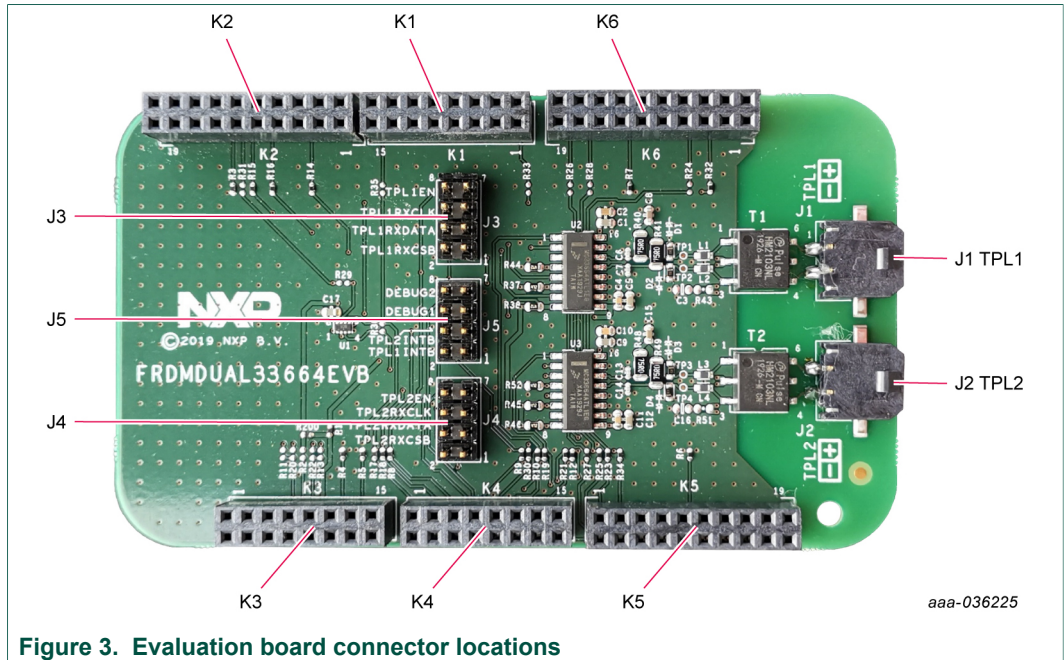

Figure 3. Evaluation board connector locations

4.2.2.1 TPL bus connectors

The connectors J1 and J2 provide access to TPL1 and TPL2 bus.

Table 3. TPL bus 1 connector J1

Schematic label	Signal name	Description
J1-1	TPL1RDTXP	TPL bus 1 – Receive/transmit input positive
J1-2	TPL1RD TXN	TPL bus 1 – Receive/transmit input negative

Table 4. TPL bus 2 connector J2

Schematic label	Signal name	Description
J2_1	TPL2RDTXP	TPL bus 2 – Receive/transmit input positive
J2_2	TPL2RD TXN	TPL bus 2 – Receive/transmit input negative

4.2.2.1.1 TPL bus selection

The FRDMDUAL33664EVB provides an option to dynamically select which TPL bus is used. Using three signals is possible to individually transmit on the TPL1 or TPL2 bus, or to transmit simultaneously on both TPL1 and TPL2 bus.

Note: For proper operation, the logic circuitry expects the unused PCS signals to be high.

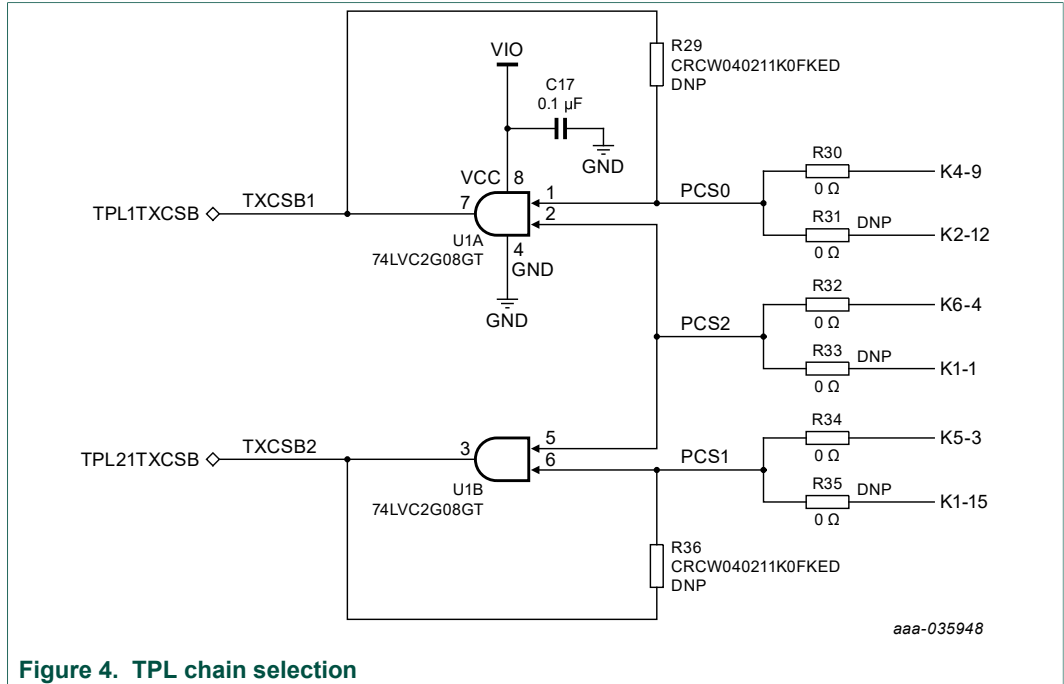

Figure 4. TPL chain selection

Table 5. TPL bus selection

Selected PCS line (low active)	Selected TPL line (low active)
PCS0	TPL1TXCSB
PCS1	TPL2TXCSB
PCS2	TPL1TXCSB and TPL2TXCSB

4.2.2.1.2 VIO selection

The FRDMDUAL33664EVB provides to option to select the IO voltage.

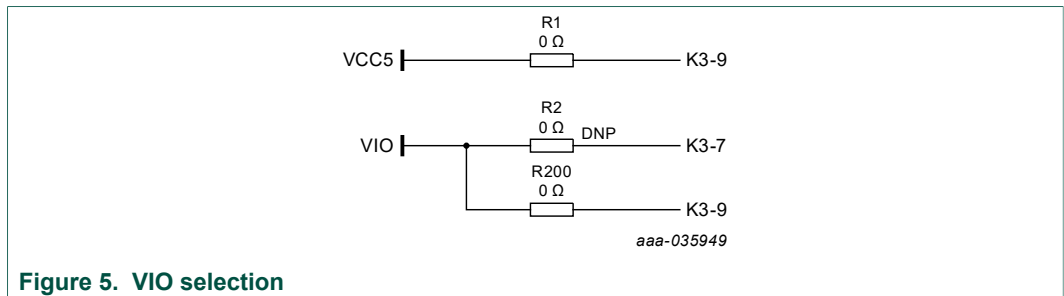

Figure 5. VIO selection

4.2.2.2 MCU interface connectors

The connectors K1 to K6 enable interface to an NXP microcontroller development platform. The mechanical dimensions and pinout is selected to fit the S32K144EVB-Q100 (recommended hardware platform). The evaluation board has a number of configuration options (0 Ohm resistors), which provides routing options.

The following table details the default configuration (S32K144EVB-Q100) signal mapping.

Table 6. Jumper (0 Ohm resistors) setting for S32K144-EVB (default)

Jumper	Setting	Signal	MCU interface
R1	populated	VCC5	K3-9
R2	—	VIO	K3-7
R200	populated	VIO	K3-9
R3	populated	GND	K2-13
R4	populated	GND	K3-11
R5	populated	GND	K3-13
R6	populated	GND	K5-12
R7	populated	GND	K6-12
R8	populated	TPL1EN	K4-5
R9	populated	TPL1INTB	K4-7
R10	populated	TPL1TXSCLK	K4-8
R11	—	TPL1TXSCLK	K3-6
R12	populated	TPL1TXDATA	K4-12
R13	—	TPL1TXDATA	K3-10
R14	populated	TPL1RXCSB	K2-5
R15	populated	TPL1RXSCLK	K2-11
R16	populated	TPL1RXDATA	K2-9
R17	populated	TPL2EN	K4-1
R18	populated	TPL2INTB	K4-3
R19	populated	TPL2TXSCLK	K4-8
R20	—	TPL2TXSCLK	K3-6
R21	populated	TPL2TXDATA	K4-12
R22	—	TPL2TXDATA	K3-10
R23	populated	TPL2RXCSB	K5-1
R24	—	TPL2RXCSB	K6-6
R25	populated	TPL2RXSCLK	K5-4
R26	—	TPL2RXSCLK	K6-18
R27	populated	TPL2RXDATA	K5-2
R28	—	TPL2RXDATA	K6-16
R29	—	TPL2RXDATA	bypass
R30	populated	TPL2RXDATA	K4-9
R31	—	TPL2RXDATA	K2-12
R32	populated	TPL2RXDATA	K6-4
R33	—	TPL2RXDATA	K1-1
R34	populated	TPL2TXCSB	K5-3
R35	—	TPL2TXCSB	K1-15
R36	—	TPL2TXCSB	bypass

The following table details the signals used for the S32K144EVB-Q100 evaluation boards.

Table 7. Signal routing for S32K144EVB-Q100

MCU Interface	Signal	MCU Signal	Description
K3-9	VCC5	5V	5.0 V supply
K3-9	VIO	5V	5.0 V IO supply
K2-13	GND	GND	Ground
K3-11	GND	GND	Ground
K3-13	GND	GND	Ground
K5-12	GND	GND	Ground
K6-12	GND	GND	Ground
K6-4	TPL12TXCSB	LPSP11_PCS0	TPL1 and TPL2 TX chip select
K4-5	TPL1EN	PTB0	TPL1 enable
K4-9	TPL1TXCSB	PTA6/LPSP11_PCS1	TPL1 TX chip select
K4-7	TPL1INTB	PTB1	TPL1 interrupt
K4-8	TPL12TXCLK	PTB14/LPSP11_SCK	TPL1 and TPL2 TX clock
K4-12	TPL12TXDATA	PTB16/LPSP11_SOUT	TPL1 and TPL2 TX data
K2-5	TPL1RXCSB	PTB5/LPSP10_PCS1	TPL1 RX chip select
K2-11	TPL1RXCLK	PTB2/LPSP10_SCK	TPL1 RX clock
K2-9	TPL1RXDATA	PTB3/LPSP10_SIN	TPL1 RX data
K5-3	TPL2TXCSB	PTA16/LPSP11_PCS2	TPL2 TX chip select
K4-1	TPL2EN	PTD4	TPL2 enable
K4-3	TPL2INTB	PTB12	TPL2 interrupt
K5-1	TPL2RXCSB	PTA15/LPSP12_PCS3	TPL2 RX chip select
K5-4	TPL2RXCLK	PTE15/LPSP12_SCK	TPL2 RX clock
K5-2	TPL2RXDATA	PTE16/LPSP12_SIN	TPL2 RX data
K5-13	Debug1	PTC1	GPIO for debugging purposes
K5-15	Debug2	PTC2	GPIO for debugging purposes

4.2.2.3 Logic analyzer interface connectors J3, J4, J5

These connectors are intended for software development and debugging purposes. They allow easy access to used signals and to monitor them for instance with a logic analyzer or an oscilloscope.

Table 8. Connector J3

Pin	Name	Description
1	J3_1	Ground
2	J3_2	TPL1RXCSB
3	J3_3	Ground
4	J3_4	TPL1RXDATA
5	J3_5	Ground
6	J3_6	TPL1RXCLK
7	J3_7	Ground
8	J3_8	TPL1EN

Table 9. Connector J4

Pin	Name	Description
1	J4_1	Ground
2	J4_2	TPL2RXCSB
3	J4_3	Ground
4	J4_4	TPL2RXDATA
5	J4_5	Ground
6	J4_6	TPL2RXCLK
7	J4_7	Ground
8	J4_8	TPL2EN

Table 10. Connector J5

Pin	Name	Description
1	J5_1	Ground
2	J5_2	TPL1INTB
3	J5_3	Ground
4	J5_4	TPL2INTB
5	J5_5	Ground
6	J5_6	Debug1
7	J5_7	Ground
8	J5_8	Debug2

4.2.3 Compatible NXP MCU development platforms

FRDMDUAL33664EVB is compatible with the S32K144EVB-Q100 MCU development platform.

The information related to MCU development platform ordering and instruction is available at nxp.com.

4.3 Schematic, board layout and bill of materials

The schematic, board layout and bill of materials for the FRDMDUAL33664EVB evaluation board are available at <http://www.nxp.com/FRDMDUAL33664EVB>.

5 Configuring the hardware

The FRDMDUAL33664EVB is configured as a shield board for the S32K144EVB-Q100 board. It can also be used in a standalone configuration. For other configurations, check mechanical/electrical fit or use, for example, a breadboard design.

5.1 S32K144EVB-Q100 board configuration

The FRDMDUAL33664EVB is configured for the S32K144EVB-Q100 board by default. Ensure that the S32K144EVB is configured correctly before connecting both boards together.

Table 11. S32K144EVB-Q100 jumper settings

Jumper	Configuration	Description
J104	1-2	Reset signal to OpenSDA, use to enter into OpenSDA Bootloader mode
	2-3 (Default)	Reset signal direct to the MCU, use to reset S32K144
J106	1-2	S32K144 powered by 12 V power source
	2-3 (Default)	S32K144 powered by USB micro connector (Open SDA)
J109/108	1-2 (Default)	Removes CAN termination resistor

The S32K144EVB uses 5.0 V for the GPIOs (see [Figure 6](#)). The FRDMMDUAL33664EVB has the configuration resistor R200 installed to use 5.0 V for the VIO.

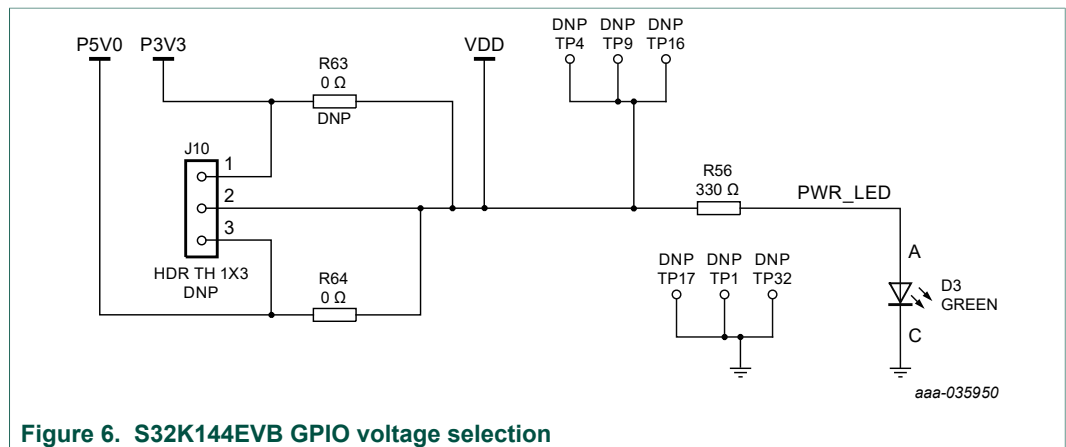

Figure 6. S32K144EVB GPIO voltage selection

When both boards are connected, the SPI and other signals are directly connected with suitable MCU pins. Power is supplied to the FRDMMDUAL33664EVB through the 5.0 V from the S32K144EVB. No external power supply is required.

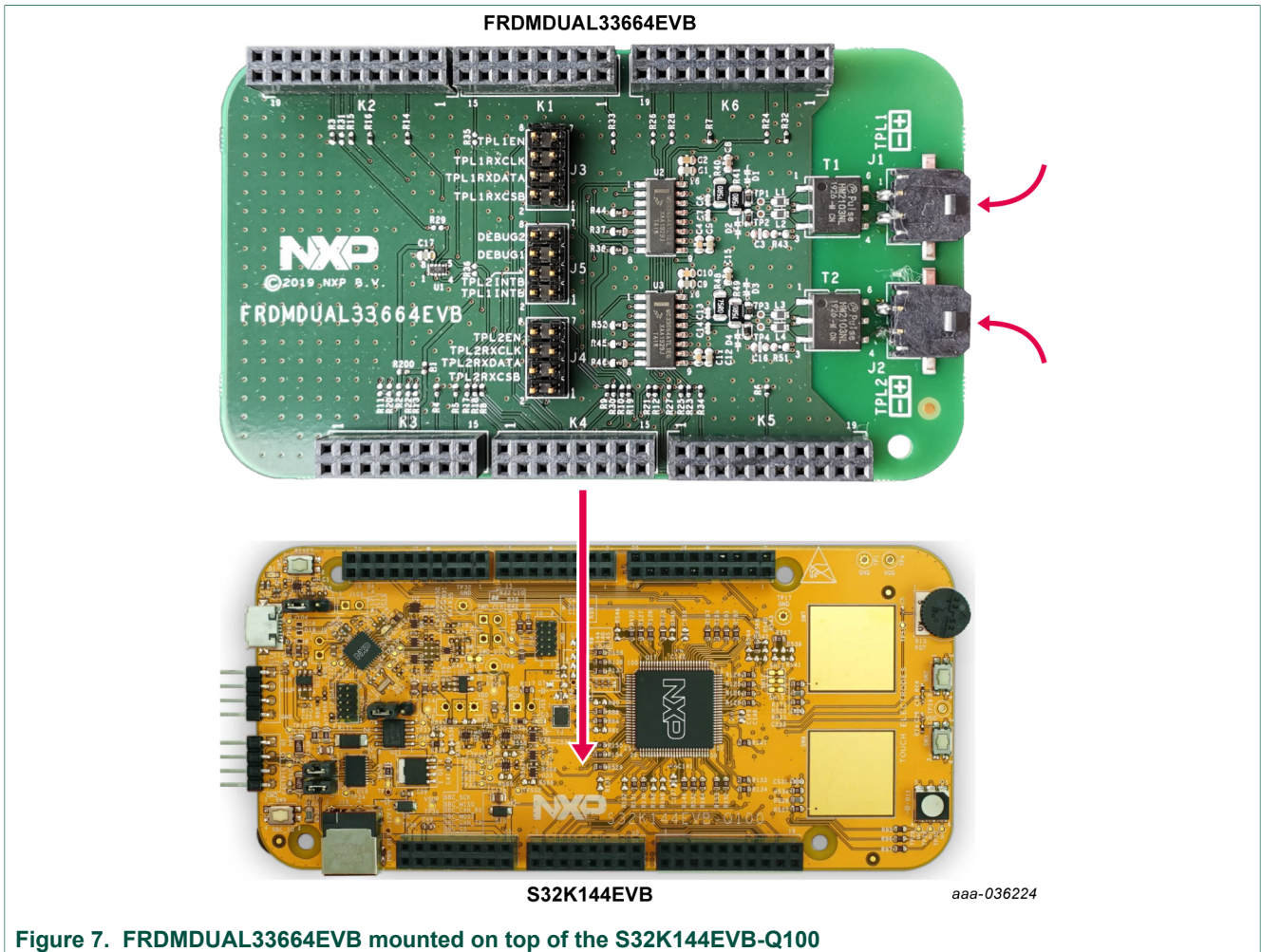

Figure 7. FRDMDUAL33664EVB mounted on top of the S32K144EVB-Q100

5.2 Standalone or other microcontroller platforms

When the board is used in standalone or with other microcontroller platforms, the SPI signals must be manually connected to the MCU interface connectors K1 to K6.

Table 12. Standalone configuration

MCU Interface	Signal	Description
K3-9	VCC5	5.0 V supply
K3-7	VIO	3.3 V supply
K2-13	GND	Ground
K3-11	GND	Ground
K3-13	GND	Ground
K5-12	GND	Ground
K6-12	GND	Ground
K6-4	TPL12TXCSB	TPL1 and TPL2 TX chip select
K4-5	TPL1EN	TPL1 enable
K4-9	TPL1TXCSB	TPL1 TX chip select
K4-7	TPL1INTB	TPL1 interrupt

MCU Interface	Signal	Description
K4-8	TPL12TXCLK	TPL1 and TPL2 TX clock
K4-12	TPL12TXDATA	TPL1 and TPL2 TX data
K2-5	TPL1RXCSB	TPL1 RX chip select
K2-11	TPL1RXCLK	TPL1 RX clock
K2-9	TPL1RXDATA	TPL1 RX data
K5-3	TPL2XCSB	TPL2 TX chip select
K4-1	TPL2EN	TPL2 enable
K4-3	TPL2INTB	TPL2 interrupt
K5-1	TPL2RXCSB	TPL2 RX chip select
K5-4	TPL2RXCLK	TPL2 RX clock
K5-2	TPL2RXDATA	TPL2 RX data
K5-13	Debug1	GPIO for debugging purposes
K5-15	Debug2	GPIO for debugging purposes

Required power supply connections are:

- VCC5 must be provided with 5.0 V
- VIO must be provided with 3.3 V or 5.0 V depending on the required communication signal levels

6 References

- [1] **FRDM DUAL33664EVB** — detailed information on this board, including documentation, downloads, and software and tools
<http://www.nxp.com/FRDM DUAL33664EVB>
- [2] **MC33664** — product information on MC33664, Isolated network high-speed transceiver
<http://www.nxp.com/MC33664>
- [3] **S32K144EVB-Q100** — detailed information on this board, including documentation, downloads, and software and tools
<https://www.nxp.com/S32K144EVB>

7 Revision history

Revision history

Rev	Date	Description
v.1	20200115	Initial version

8 Legal information

8.1 Definitions

Draft — The document is a draft version only. The content is still under internal review and subject to formal approval, which may result in modifications or additions. NXP Semiconductors does not give any representations or warranties as to the accuracy or completeness of information included herein and shall have no liability for the consequences of use of such information.

8.2 Disclaimers

Limited warranty and liability — Information in this document is believed to be accurate and reliable. However, NXP Semiconductors does not give any representations or warranties, expressed or implied, as to the accuracy or completeness of such information and shall have no liability for the consequences of use of such information. NXP Semiconductors takes no responsibility for the content in this document if provided by an information source outside of NXP Semiconductors. In no event shall NXP Semiconductors be liable for any indirect, incidental, punitive, special or consequential damages (including - without limitation - lost profits, lost savings, business interruption, costs related to the removal or replacement of any products or rework charges) whether or not such damages are based on tort (including negligence), warranty, breach of contract or any other legal theory. Notwithstanding any damages that customer might incur for any reason whatsoever, NXP Semiconductors' aggregate and cumulative liability towards customer for the products described herein shall be limited in accordance with the Terms and conditions of commercial sale of NXP Semiconductors.

Right to make changes — NXP Semiconductors reserves the right to make changes to information published in this document, including without limitation specifications and product descriptions, at any time and without notice. This document supersedes and replaces all information supplied prior to the publication hereof.

Applications — Applications that are described herein for any of these products are for illustrative purposes only. NXP Semiconductors makes no representation or warranty that such applications will be suitable for the specified use without further testing or modification. Customers are responsible for the design and operation of their applications and products using NXP Semiconductors products, and NXP Semiconductors accepts no liability for any assistance with applications or customer product design. It is customer's sole responsibility to determine whether the NXP Semiconductors product is suitable and fit for the customer's applications and products planned, as well as for the planned application and use of customer's third party customer(s). Customers should provide appropriate design and operating safeguards to minimize the risks associated with their applications and products. NXP Semiconductors does not accept any liability related to any default, damage, costs or problem which is based on any weakness or default in the customer's applications or products, or the application or use by customer's third party customer(s). Customer is responsible for doing all necessary testing for the customer's applications and products using NXP Semiconductors products in order to avoid a

default of the applications and the products or of the application or use by customer's third party customer(s). NXP does not accept any liability in this respect.

Suitability for use in automotive applications — This NXP Semiconductors product has been qualified for use in automotive applications. Unless otherwise agreed in writing, the product is not designed, authorized or warranted to be suitable for use in life support, life-critical or safety-critical systems or equipment, nor in applications where failure or malfunction of an NXP Semiconductors product can reasonably be expected to result in personal injury, death or severe property or environmental damage. NXP Semiconductors and its suppliers accept no liability for inclusion and/or use of NXP Semiconductors products in such equipment or applications and therefore such inclusion and/or use is at the customer's own risk.

Export control — This document as well as the item(s) described herein may be subject to export control regulations. Export might require a prior authorization from competent authorities.

Evaluation products — This product is provided on an "as is" and "with all faults" basis for evaluation purposes only. NXP Semiconductors, its affiliates and their suppliers expressly disclaim all warranties, whether express, implied or statutory, including but not limited to the implied warranties of non-infringement, merchantability and fitness for a particular purpose. The entire risk as to the quality, or arising out of the use or performance, of this product remains with customer. In no event shall NXP Semiconductors, its affiliates or their suppliers be liable to customer for any special, indirect, consequential, punitive or incidental damages (including without limitation damages for loss of business, business interruption, loss of use, loss of data or information, and the like) arising out of the use of or inability to use the product, whether or not based on tort (including negligence), strict liability, breach of contract, breach of warranty or any other theory, even if advised of the possibility of such damages. Notwithstanding any damages that customer might incur for any reason whatsoever (including without limitation, all damages referenced above and all direct or general damages), the entire liability of NXP Semiconductors, its affiliates and their suppliers and customer's exclusive remedy for all of the foregoing shall be limited to actual damages incurred by customer based on reasonable reliance up to the greater of the amount actually paid by customer for the product or five dollars (US\$5.00). The foregoing limitations, exclusions and disclaimers shall apply to the maximum extent permitted by applicable law, even if any remedy fails of its essential purpose.

Translations — A non-English (translated) version of a document is for reference only. The English version shall prevail in case of any discrepancy between the translated and English versions.

8.3 Trademarks

Notice: All referenced brands, product names, service names and trademarks are the property of their respective owners.

NXP — is a trademark of NXP B.V.

SMARTMOS — is a trademark of NXP B.V.

Tables

Tab. 1.	Evaluation board component descriptions	4	Tab. 7.	Signal routing for S32K144EVB-Q100	9
Tab. 2.	Modes of operation	5	Tab. 8.	Connector J3	9
Tab. 3.	TPL bus 1 connector J1	6	Tab. 9.	Connector J4	10
Tab. 4.	TPL bus 2 connector J2	6	Tab. 10.	Connector J5	10
Tab. 5.	TPL bus selection	7	Tab. 11.	S32K144EVB-Q100 jumper settings	11
Tab. 6.	Jumper (0 Ohm resistors) setting for S32K144-EVB (default)	8	Tab. 12.	Standalone configuration	12

Figures

Fig. 1.	Evaluation board featured component locations	3	Fig. 5.	VIO selection	7
Fig. 2.	Block diagram	5	Fig. 6.	S32K144EVB GPIO voltage selection	11
Fig. 3.	Evaluation board connector locations	6	Fig. 7.	FRDMDUAL33664EVB mounted on top of the S32K144EVB-Q100	12
Fig. 4.	TPL chain selection	7			