

UM11568

Introduction to the FRDMSTBANBP8XD Shield Board

Rev. 1 — 19 March 2021

User manual

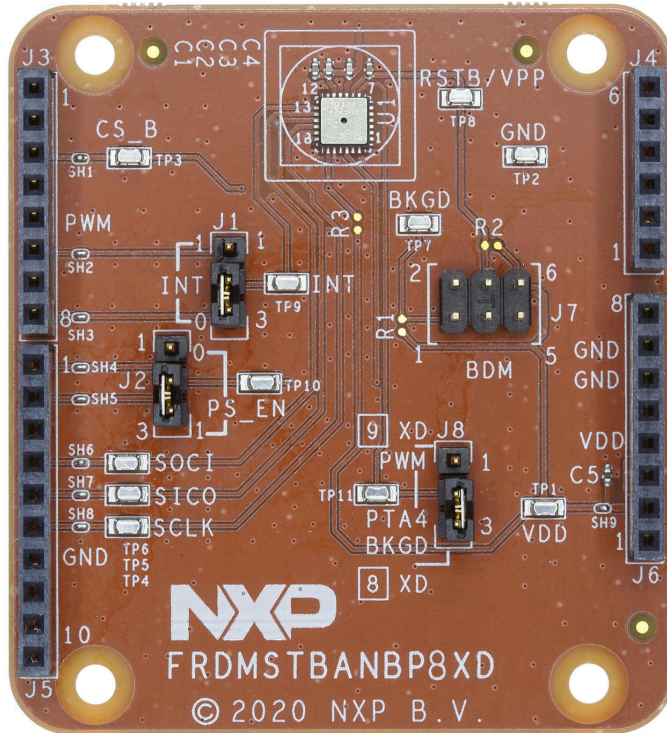

NXP provides the enclosed product(s) under the following conditions:

This reference design is intended for use of ENGINEERING DEVELOPMENT OR EVALUATION PURPOSES ONLY. It is provided as a sample IC pre-soldered to a printed circuit board to make it easier to access inputs, outputs, and supply terminals. This reference design may be used with any development system or other source of I/O signals by simply connecting it to the host MCU or computer board via off-the-shelf cables. Final device in an application will be heavily dependent on proper printed circuit board layout and heat sinking design as well as attention to supply filtering, transient suppression, and I/O signal quality.

The goods provided may not be complete in terms of required design, marketing, and or manufacturing related protective considerations, including product safety measures typically found in the end product incorporating the goods. Due to the open construction of the product, it is the user's responsibility to take any and all appropriate precautions with regard to electrostatic discharge. In order to minimize risks associated with the customers applications, adequate design and operating safeguards must be provided by the customer to minimize inherent or procedural hazards. For any safety concerns, contact NXP sales and technical support services.

Should this reference design not meet the specifications indicated in the kit, it may be returned within 30 days from the date of delivery and will be replaced by a new kit.

NXP reserves the right to make changes without further notice to any products herein. NXP makes no warranty, representation or guarantee regarding the suitability of its products for any particular purpose, nor does NXP assume any liability arising out of the application or use of any product or circuit, and specifically disclaims any and all liability, including without limitation consequential or incidental damages. “Typical” parameters can and do vary in different applications and actual performance may vary over time. All operating parameters, including “Typical”, must be validated for each customer application by customer’s technical experts.

NXP does not convey any license under its patent rights nor the rights of others. NXP products are not designed, intended, or authorized for use as components in systems intended for surgical implant into the body, or other applications intended to support or sustain life,

or for any other application in which the failure of the NXP product could create a situation where personal injury or death may occur. Should the Buyer purchase or use NXP products for any such unintended or unauthorized application, the Buyer shall indemnify and hold NXP and its officers, employees, subsidiaries, affiliates, and distributors harmless against all claims, costs, damages, and expenses, and reasonable attorney fees arising out of, directly or indirectly, any claim of personal injury or death associated with such unintended or unauthorized use, even if such claim alleges NXP was negligent regarding the design or manufacture of the part.

1 Finding Kit Resources and Information on the NXP Web Site

NXP Semiconductors provides online resources for this evaluation board and its supported device(s) on <http://www.nxp.com>.

The information page for the NBP8FD battery pressure monitor sensor can be found at:

<https://www.nxp.com/products/sensors/pressure-sensors/highly-integrated-battery-pressure-monitor-sensor:NBP8-9x>.

The information page for the FRDMSTBANBP8XD evaluation shield board can be found at:

<http://www.nxp.com/FRDMSTBANBP8XD>

The information page provides overview information, documentation, software, tools, ordering information, and a Getting Started tab. The Getting Started tab contains quick-reference information applicable to using the FRDMSTBANBP8XD, including the downloadable assets referenced in this document.

1.1 Collaborate in the NXP community

The NXP Community is for sharing ideas and tips, asking and answering technical questions, and receiving input on just about any embedded design topic.

The NXP Community is at <http://community.nxp.com>.

2 Getting Started

2.1 Kit contents

The FRDMSTBANBP8XD contents include:

- FRDMSTBANBP8XD shield board with Arduino headers

2.2 Additional hardware

The FRDMSTBANBP8XD can be paired with a variety of NXP MCU boards. However, an evaluation project is available to customers who select the FRDM-KW36 board. More information is detailed in [Section 3 "Getting to Know the Hardware"](#).

3 Getting to Know the Hardware

3.1 General description: FRDMSTBANBP8XD

The FRDMSTBANBP8XD shield board incorporates an NBP8FD fully integrated battery pressure monitor sensor that offers:

- a small footprint in a 4 x 4 mm package
- low power consumption
- PWM
- SPI
- ready/interrupt and power supply enable capabilities

The FRDMSTBANBP8XD shield board can be easily connected to an NXP Freedom MCU board via the Arduino headers for evaluation. The FRDM-KW36 board is recommended.

Users can connect the two boards to evaluate the NPB8XD battery pressure monitor sensor by using either a terminal program and commands or a demo GUI. In either case, the hardware facilitates software development.

These boards provide an intuitive way to change the interrupts, PWM, and power supply enable signals for specific pin configurations. The board also contains test points that are typically used for evaluation. The NBP8X data sheet provides additional information and configuration details about these features.

3.2 NBP8FD pressure monitor sensor features

The NBP8 family consists of small QFN (4 mm x 4 mm x 1.98 mm), fully integrated battery pressure monitoring sensors (BPMS). The NBP8 BPMS solution integrates an 8-bit central processing unit (CPU) and NXP-provided firmware to create a ready-to-use pressure sensor. Features include:

- Transducer measurement interfaces with low-power AFE:
 - 10-bit compensated pressure sense element
 - 8-bit compensated internal device temperature measurement
 - 8-bit compensated internal device voltage measurement
- 12-entry pressure FIFO
- Selectable host wake-up indications:
 - Fixed pressure threshold breach
 - Relative pressure threshold breach
 - Pressure rate of change threshold breach
- Client SPI to support host access to internal peripherals, registers, and memory
- Qualified in compliance with AEC-Q100, Rev. H
- User-selectable sampling interval
- Low-voltage detection

3.3 Example system block diagram

[Figure 1](#) shows an example block diagram of the NBP8 with an external host. The low-power configuration shows that when a pressure breach occurs, the NPB8 can enable the power supply to the host.

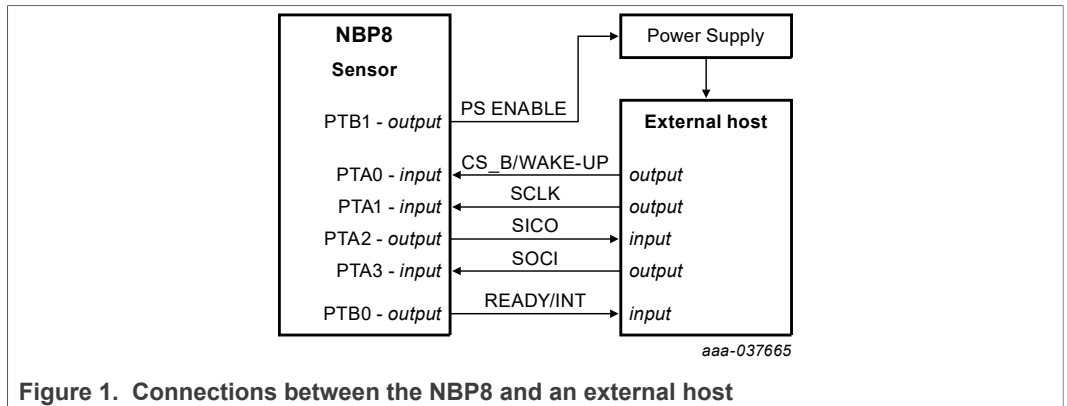

Figure 1. Connections between the NBP8 and an external host

4 FRDMSTBANBP8XD Featured Components

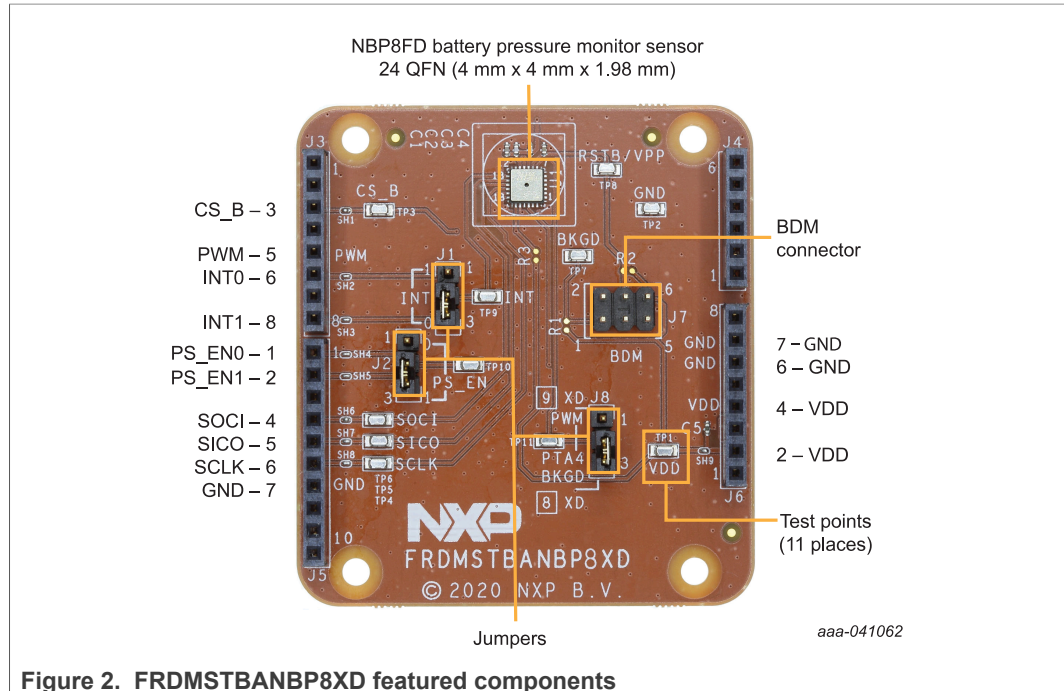

Figure 2. FRDMSTBANBP8XD featured components

The FRDMSTBANBP8XD shield board comes with standard Arduino headers and can be paired and connected with NXP Freedom MCU boards for user evaluations and software development. For quick evaluation and prototyping, NXP provides a demo project targeted to the FRDM-KW36 board and hardware design files that help reduce the time to market.

As shown in [Figure 2](#), the following signals are available on the Arduino headers of the FRDMSTBANBP8XD shield board:

- The interrupt signals, INT_x can be ported to either J3-6 or J3-8 by selector jumper J1.
- The power supply enable signal, PS_EN_x can be ported to either J5-1 or J5-2 by selector jumper J2.
- The PWM signal (NPB9FD only) can be ported to J3-5 by selector jumper J8, pins 1-2. Note that the default setting is the BKGD signal (J8, pins 2-3) used to program U1 via the BDM port through J7.
- The SPI interface is provided through J3 and J5. These are:
 - J3-3, CS_B, Client Select
 - J5-4, SOCI, Server-Out-Client-In data
 - J5-5, SICO, Server-In-Client-Out data
 - J5-6, SCLK, SPI clock
- VDD is supplied through J6-2 / J6-4. This is typically supplied through a Freedom MCU board such as the FRDM-KW36.
- GND is supplied through J6-6 / J6-7. This is typically supplied through a Freedom MCU board such as the FRDM-KW36.

4.1 Jumpers

Table 1. Jumpers

Jumper	Position	Function
J1	1–2	Connects INT0 signal from Arduino J3-6 to Interrupt pin (Pin 13) on NBP8
	2–3 (default)	Connects INT1 signal from Arduino J3-8 to Interrupt pin (Pin 13) on NBP8
J2	1–2	Connects PS_EN0 signal from Arduino J5-1 to Power Supply Enable pin (Pin 22) on NBP8
	2–3 (default)	Connects PS_EN1 signal from Arduino J5-2 to Power Supply Enable pin (Pin 22) on NBP8
J8	1–2	Connects PWM signal at PTA4 (Pin 7) on NBP8 to Arduino J3-5
	2–3 (default)	Selects Background Debug Mode (BDM) at PTA4 (Pin 7) on NBP8

4.2 BDM Multilink connector (J7)

Table 2. BDM connector

Pin	Name	Function
1	BKGD	Connects to Background Debug Mode signal (PTA4 - Pin 7) on NBP8
2	GND	Ground
3	NC	No connection
4	RSTB/VPP	Connects to RST_B (Pin 8) on NBP8
5	NC	No connection
6	VDD	VDD power supply

4.3 Test points

For a definition of the 11 FRDMSTBANBP8XD test points, see schematic (available [here](#) for customers who purchase the board).

5 References

Table 3. References

Item	Description	Link
NBP8FD	Battery pressure monitor sensor product page	https://www.nxp.com/products/sensors/pressure-sensors/highly-integrated-battery-pressure-monitor-sensor:NBP8-9x
FRDMSTBANBP8XD design files	Tools and software tab	http://www.nxp.com/FRDMSTBANBP8XD

6 Revision history

Table 4. Revision history

Document ID	Release date	Data sheet status	Supersedes
UM11568 v.1	20210319	Initial release	—
Modifications	• NA		

7 Legal information

7.1 Definitions

Draft — A draft status on a document indicates that the content is still under internal review and subject to formal approval, which may result in modifications or additions. NXP Semiconductors does not give any representations or warranties as to the accuracy or completeness of information included in a draft version of a document and shall have no liability for the consequences of use of such information.

7.2 Disclaimers

Limited warranty and liability — Information in this document is believed to be accurate and reliable. However, NXP Semiconductors does not give any representations or warranties, expressed or implied, as to the accuracy or completeness of such information and shall have no liability for the consequences of use of such information. NXP Semiconductors takes no responsibility for the content in this document if provided by an information source outside of NXP Semiconductors. In no event shall NXP Semiconductors be liable for any indirect, incidental, punitive, special or consequential damages (including - without limitation - lost profits, lost savings, business interruption, costs related to the removal or replacement of any products or rework charges) whether or not such damages are based on tort (including negligence), warranty, breach of contract or any other legal theory. Notwithstanding any damages that customer might incur for any reason whatsoever, NXP Semiconductors' aggregate and cumulative liability towards customer for the products described herein shall be limited in accordance with the Terms and conditions of commercial sale of NXP Semiconductors.

Right to make changes — NXP Semiconductors reserves the right to make changes to information published in this document, including without limitation specifications and product descriptions, at any time and without notice. This document supersedes and replaces all information supplied prior to the publication hereof.

Suitability for use — NXP Semiconductors products are not designed, authorized or warranted to be suitable for use in life support, life-critical or safety-critical systems or equipment, nor in applications where failure or malfunction of an NXP Semiconductors product can reasonably be expected to result in personal injury, death or severe property or environmental damage. NXP Semiconductors and its suppliers accept no liability for inclusion and/or use of NXP Semiconductors products in such equipment or applications and therefore such inclusion and/or use is at the customer's own risk.

Applications — Applications that are described herein for any of these products are for illustrative purposes only. NXP Semiconductors makes no representation or warranty that such applications will be suitable for the specified use without further testing or modification. Customers are responsible for the design and operation of their applications and products using NXP Semiconductors products, and NXP Semiconductors accepts no liability for any assistance with applications or customer product design. It is customer's sole responsibility to determine whether the NXP Semiconductors product is suitable and fit for the customer's applications and products planned, as well as for the planned application and use of customer's third party customer(s). Customers should provide appropriate design and operating safeguards to minimize the risks associated with their applications and products. NXP Semiconductors does not accept any liability related to any default, damage, costs or problem which is based on any weakness or default in the customer's applications or products, or the application or use by customer's third party customer(s). Customer is

responsible for doing all necessary testing for the customer's applications and products using NXP Semiconductors products in order to avoid a default of the applications and the products or of the application or use by customer's third party customer(s). NXP does not accept any liability in this respect.

Export control — This document as well as the item(s) described herein may be subject to export control regulations. Export might require a prior authorization from competent authorities.

Evaluation products — This product is provided on an "as is" and "with all faults" basis for evaluation purposes only. NXP Semiconductors, its affiliates and their suppliers expressly disclaim all warranties, whether express, implied or statutory, including but not limited to the implied warranties of non-infringement, merchantability and fitness for a particular purpose. The entire risk as to the quality, or arising out of the use or performance, of this product remains with customer. In no event shall NXP Semiconductors, its affiliates or their suppliers be liable to customer for any special, indirect, consequential, punitive or incidental damages (including without limitation damages for loss of business, business interruption, loss of use, loss of data or information, and the like) arising out of the use of or inability to use the product, whether or not based on tort (including negligence), strict liability, breach of contract, breach of warranty or any other theory, even if advised of the possibility of such damages. Notwithstanding any damages that customer might incur for any reason whatsoever (including without limitation, all damages referenced above and all direct or general damages), the entire liability of NXP Semiconductors, its affiliates and their suppliers and customer's exclusive remedy for all of the foregoing shall be limited to actual damages incurred by customer based on reasonable reliance up to the greater of the amount actually paid by customer for the product or five dollars (US\$5.00). The foregoing limitations, exclusions and disclaimers shall apply to the maximum extent permitted by applicable law, even if any remedy fails of its essential purpose.

Translations — A non-English (translated) version of a document is for reference only. The English version shall prevail in case of any discrepancy between the translated and English versions.

Security — Customer understands that all NXP products may be subject to unidentified or documented vulnerabilities. Customer is responsible for the design and operation of its applications and products throughout their lifecycles to reduce the effect of these vulnerabilities on customer's applications and products. Customer's responsibility also extends to other open and/or proprietary technologies supported by NXP products for use in customer's applications. NXP accepts no liability for any vulnerability. Customer should regularly check security updates from NXP and follow up appropriately. Customer shall select products with security features that best meet rules, regulations, and standards of the intended application and make the ultimate design decisions regarding its products and is solely responsible for compliance with all legal, regulatory, and security related requirements concerning its products, regardless of any information or support that may be provided by NXP. NXP has a Product Security Incident Response Team (PSIRT) (reachable at PSIRT@nxp.com) that manages the investigation, reporting, and solution release to security vulnerabilities of NXP products.

7.3 Trademarks

Notice: All referenced brands, product names, service names and trademarks are the property of their respective owners.

NXP — wordmark and logo are trademarks of NXP B.V.

SafeAssure — is a trademark of NXP B.V.

Tables

Tab. 1.	Jumpers	8	Tab. 3.	References	9
Tab. 2.	BDM connector	8	Tab. 4.	Revision history	10

Figures

Fig. 1. Connections between the NBP8 and an external host6

Fig. 2. FRDMSTBANBP8XD featured components7