

HybridPACK™ Drive module with CoolSiC™ Automotive MOSFET

Features

- Electrical features
 - $V_{DS} = 1200\text{ V}$
 - $I_{D,nom} = 400\text{ A}$
 - New semiconductor material - silicon carbide
 - Low $R_{DS,on}$
 - Low switching losses
 - Low Q_g and C_{rSS}
 - Low inductive design $<10\text{ nH}$
 - $T_{vj,op} = 150^\circ\text{C}$
- Mechanical features
 - 4.2 kV DC 1 second insulation
 - High creepage and clearance distances
 - Compact design
 - High power density
 - Direct-cooled PinFin base plate
 - High-performance Si3N4 ceramic
 - Guiding elements for PCB and cooler assembly
 - Integrated NTC temperature sensor
 - PressFIT contact technology
 - RoHS compliant
 - UL 94 V0 module frame

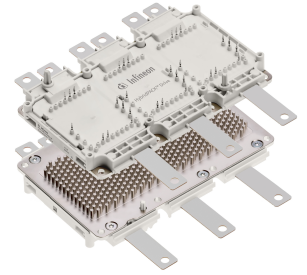

Potential applications

- Automotive applications
- (Hybrid) electrical vehicles (H)EV
- Motor drives
- Commercial agriculture vehicles

Product validation

- Qualified according to AQC 324, release no.: 03.1/2021

Description

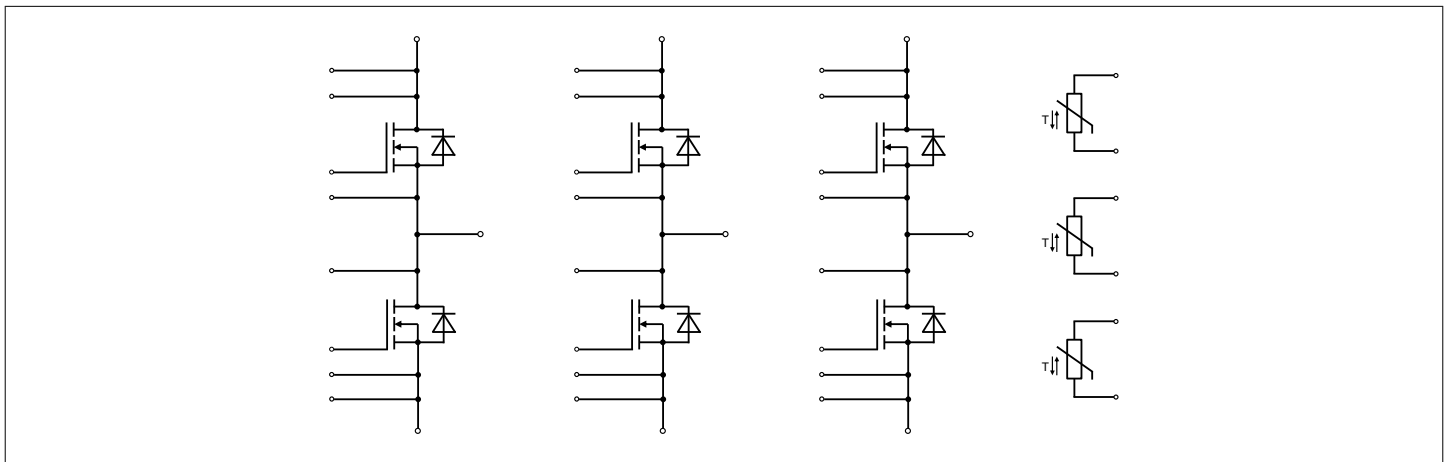

Table of contents

	Description	1
	Features	1
	Potential applications	1
	Product validation	1
	Table of contents	2
1	Package	3
2	MOSFET	4
3	Body diode	5
4	NTC-Thermistor	6
5	Characteristics diagrams	7
6	Circuit diagram	12
7	Package outlines	13
8	Module label code	14
	Revision history	15
	Disclaimer	16

1 Package

Table 1 Insulation coordination

Parameter	Symbol	Note or test condition	Values	Unit
Isolation test voltage	V_{ISOL}	RMS, $f = 0$ Hz, $t = 1$ sec	4.20	kV
Material of module baseplate			Ni+Cu ¹⁾	
Internal isolation		basic insulation (class 1, IEC 61140)	Si3N4	
Creepage distance	d_{creep}	terminal to heatsink	9.0	mm
Creepage distance	d_{creep}	terminal to terminal	9.0	mm
Clearance	d_{clear}	terminal to heatsink	4.5	mm
Clearance	d_{clear}	terminal to terminal	4.5	mm
Comparative tracking index	CTI		> 200	

1) Ni plated Cu baseplate

Table 2 Maximum rated values

Parameter	Symbol	Note or test condition	Values	Unit
Maximum RMS module terminal current	$I_{t,rms}$	$T_{terminal} = 105$ °C, $T_f = 75$ °C	500	A

Table 3 Characteristic values

Parameter	Symbol	Note or test condition	Values			Unit
			Min.	Typ.	Max.	
Pressure drop in cooling circuit	Δp	$\Delta V/\Delta t = 10$ dm ³ /min, 50% water / 50% ethylenglycol, $T_f = 60$ °C		64 ¹⁾		mbar
Maximum pressure in cooling circuit	p	$T_{baseplate} < 40$ °C (relative pressure)			2.5	bar
		$T_{baseplate} \geq 40$ °C (relative pressure)			2.0	
Stray inductance module	$L_{s,DS}$			8.5		nH
Module lead resistance, terminals - chip	$R_{DD'+SS'}$	$T_f = 25$ °C, per switch		0.75		mΩ
Storage temperature	T_{stg}		-40		125	°C
Mounting torque for module mounting	M	Screw M4 baseplate to heatsink	1.8	2.0	2.2	Nm
Weight	G			729		g

1) Cooler design and flow direction according to application note AN-HPDPERF-ASSEMBLY

2 MOSFET

Table 4 Maximum rated values

Parameter	Symbol	Note or test condition	Values	Unit
Drain-source voltage	V_{DSS}		$T_{vj} = 25\text{ °C}$	1200 V
DC drain current	$I_{D,nom}$	$V_{GS} = 15\text{ V}, T_f = 60\text{ °C}$	$T_{vj,max} = 175\text{ °C}$	400 A
Pulsed drain current	$I_{D,pulse}$	verified by design, t_p limited by $T_{vj,max}$		800 A
Gate-source voltage	V_{GSS}			-10/20 V

Table 5 Characteristic values

Parameter	Symbol	Note or test condition	Values			Unit	
			Min.	Typ.	Max.		
Drain-source on-resistance	$R_{DS,on}$	$I_D = 400\text{ A}, V_{GS} = 15\text{ V}$	$T_{vj} = 25\text{ °C}$	2.75	3.70	mΩ	
			$T_{vj} = 125\text{ °C}$	4.00			
			$T_{vj} = 150\text{ °C}$	4.55			
Gate threshold voltage	$V_{GS,th}$	$I_D = 240\text{ mA}, V_{GS} = V_{DS}$, (tested after 1ms pulse at $V_{GS} = +20\text{ V}$)	$T_{vj} = 25\text{ °C}$	3.25	4.40	5.55	V
Total gate charge	Q_G	$V_{DS} = 600\text{ V}, V_{GS} = -5/15\text{ V}$		1.32			μC
Internal gate resistor	$R_{G,int}$		$T_{vj} = 25\text{ °C}$	0.23			Ω
Input capacitance	C_{iss}	$f = 1\text{ MHz}, V_{DS} = 600\text{ V}, V_{GS} = 0\text{ V}$	$T_{vj} = 25\text{ °C}$	42.6			nF
Output capacitance	C_{oss}	$f = 1\text{ MHz}, V_{DS} = 600\text{ V}, V_{GS} = 0\text{ V}$	$T_{vj} = 25\text{ °C}$	1.86			nF
Reverse transfer capacitance	C_{rss}	$f = 1\text{ MHz}, V_{DS} = 600\text{ V}, V_{GS} = 0\text{ V}$	$T_{vj} = 25\text{ °C}$	0.17			nF
C_{oss} stored energy	E_{oss}	$V_{DS} = 600\text{ V}, V_{GS} = -5/15\text{ V}$	$T_{vj} = 25\text{ °C}$	438			μJ
Drain-source leakage current	I_{DSX}	$V_{GS} = -5\text{ V}, V_{DSS} = 1200\text{ V}$	$T_{vj} = 25\text{ °C}$			100	μA
Gate-source leakage current	I_{GSS}	$V_{GS} = 20\text{ V}, V_{DS} = 0\text{ V}$	$T_{vj} = 25\text{ °C}$			400	nA
Turn-on delay time, inductive load	$t_{d,on}$	$I_D = 400\text{ A}, R_{G,on} = 5.1\text{ Ω}, V_{GS} = -5/15\text{ V}, V_{DS} = 600\text{ V}$	$T_{vj} = 25\text{ °C}$	77			ns
			$T_{vj} = 125\text{ °C}$	62			
			$T_{vj} = 150\text{ °C}$	59			
Rise time (inductive load)	t_r	$I_D = 400\text{ A}, R_{G,on} = 5.1\text{ Ω}, V_{GS} = -5/15\text{ V}, V_{DS} = 600\text{ V}$	$T_{vj} = 25\text{ °C}$	79			ns
			$T_{vj} = 125\text{ °C}$	70			
			$T_{vj} = 150\text{ °C}$	69			

(table continues...)

Table 5 (continued) Characteristic values

Parameter	Symbol	Note or test condition	Values			Unit
			Min.	Typ.	Max.	
Turn-off delay time, inductive load	$t_{d,off}$	$I_D = 400\text{ A}, R_{G,off} = 5.1\ \Omega, V_{GS} = -5/15\text{ V}, V_{DS} = 600\text{ V}$	$T_{vj} = 25\text{ °C}$	263		ns
			$T_{vj} = 125\text{ °C}$	287		
			$T_{vj} = 150\text{ °C}$	294		
Fall time (inductive load)	t_f	$I_D = 400\text{ A}, R_{G,off} = 5.1\ \Omega, V_{GS} = -5/15\text{ V}, V_{DS} = 600\text{ V}$	$T_{vj} = 25\text{ °C}$	64		ns
			$T_{vj} = 125\text{ °C}$	64		
			$T_{vj} = 150\text{ °C}$	65		
Turn-on energy loss per pulse	E_{on}	$I_D = 400\text{ A}, R_{G,on} = 5.1\ \Omega, V_{GS} = -5/15\text{ V}, V_{DS} = 600\text{ V}, L_\sigma = 20\text{ nH}$	$T_{vj} = 25\text{ °C}, di/dt = 4\text{ kA}/\mu\text{s}$	19.48		mJ
			$T_{vj} = 125\text{ °C}, di/dt = 4.6\text{ kA}/\mu\text{s}$	19.85		
			$T_{vj} = 150\text{ °C}, di/dt = 4.6\text{ kA}/\mu\text{s}$	20.16		
Turn-off energy loss per pulse	E_{off}	$I_D = 400\text{ A}, R_{G,off} = 5.1\ \Omega, V_{GS} = -5/15\text{ V}, V_{DS} = 600\text{ V}, L_\sigma = 20\text{ nH}$	$T_{vj} = 25\text{ °C}, du/dt = 7.3\text{ kV}/\mu\text{s}$	17.61		mJ
			$T_{vj} = 125\text{ °C}, du/dt = 7.2\text{ kV}/\mu\text{s}$	17.95		
			$T_{vj} = 150\text{ °C}, du/dt = 7.1\text{ kV}/\mu\text{s}$	18.21		
Short circuit data	I_{SC}	$V_{DD} = 800\text{ V}, V_{GS} = -5/15\text{ V}, R_{G,on} = 5.1\ \Omega, R_{G,off} = 5.1\ \Omega, V_{DSmax} = V_{DSS} - L_{sDS} \cdot di/dt$	$t_{SC} = 3\ \mu\text{s}, T_{vj} = 25\text{ °C}$	5300		A
			$t_{SC} = 3\ \mu\text{s}, T_{vj} = 150\text{ °C}$	4800		
Thermal resistance, junction to cooling fluid	$R_{th,j-f}$	per MOSFET, $T_f = 60\text{ °C}, \Delta V/\Delta t = 10\text{ dm}^3/\text{min}, 50\%\text{ water} / 50\%\text{ ethylenglycol}$		0.1	0.108 ¹⁾	K/W
Temperature under switching conditions	$T_{vj,op}$		-40		150	°C

1) EoL criteria see AQG324, verified by characterization with 4.5 sigma. Cooler design and flow direction according to application note AN-HPDPERF-ASSEMBLY

3 Body diode

Table 6 Maximum rated values

Parameter	Symbol	Note or test condition	Values	Unit
DC body diode forward current	$I_{F,S}$	$T_{vj,max} = 175\text{ °C}, T_f = 60\text{ °C}, V_{GS} = -5\text{ V}$	210	A
Pulsed body diode current	$I_{F,S,pulse}$	verified by design, t_p limited by $T_{vj,max}$	800	A

Table 7 Characteristic values

Parameter	Symbol	Note or test condition	Values			Unit	
			Min.	Typ.	Max.		
Forward voltage	$V_{F,SD}$	$I_{F,S} = 400 \text{ A}, V_{GS} = -5 \text{ V}$	$T_{vj} = 25 \text{ }^\circ\text{C}$		4.42	6.15	V
			$T_{vj} = 125 \text{ }^\circ\text{C}$		4.22		
			$T_{vj} = 150 \text{ }^\circ\text{C}$		4.16		
Peak reverse recovery current	I_{rrm}	$I_{F,S} = 400 \text{ A}, V_{GS} = -5 \text{ V}, V_{R,DS} = 600 \text{ V}$	$T_{vj} = 25 \text{ }^\circ\text{C}$		165		A
			$T_{vj} = 125 \text{ }^\circ\text{C}$		287		
			$T_{vj} = 150 \text{ }^\circ\text{C}$		309		
Recovered charge	Q_{rr}	$I_{F,S} = 400 \text{ A}, V_{GS} = -5 \text{ V}, V_{R,DS} = 600 \text{ V}$	$T_{vj} = 25 \text{ }^\circ\text{C}$		11.20		μC
			$T_{vj} = 125 \text{ }^\circ\text{C}$		18.10		
			$T_{vj} = 150 \text{ }^\circ\text{C}$		19.30		
Reverse recovery energy	E_{rec}	$I_{F,S} = 400 \text{ A}, V_{GS} = -5 \text{ V}, V_{R,DS} = 600 \text{ V}$	$T_{vj} = 25 \text{ }^\circ\text{C}, -di/dt = 5.9 \text{ kA}/\mu\text{s}$		1.4		mJ
			$T_{vj} = 125 \text{ }^\circ\text{C}, -di/dt = 6.9 \text{ kA}/\mu\text{s}$		4.0		
			$T_{vj} = 150 \text{ }^\circ\text{C}, -di/dt = 6.9 \text{ kA}/\mu\text{s}$		4.7		

4 NTC-Thermistor

Table 8 Characteristic values

Parameter	Symbol	Note or test condition	Values			Unit
			Min.	Typ.	Max.	
Rated resistance	R_{25}	$T_{NTC} = 25 \text{ }^\circ\text{C}$		5		k Ω
Deviation of R_{100}	$\Delta R/R$	$T_{NTC} = 100 \text{ }^\circ\text{C}, R_{100} = 493 \text{ } \Omega$	-5		5	%
Power dissipation	P_{25}	$T_{NTC} = 25 \text{ }^\circ\text{C}$			20	mW
B-value	$B_{25/50}$	$R_2 = R_{25} \exp[B_{25/50}(1/T_2 - 1/(298,15 \text{ K}))]$		3375		K
B-value	$B_{25/80}$	$R_2 = R_{25} \exp[B_{25/80}(1/T_2 - 1/(298,15 \text{ K}))]$		3411		K
B-value	$B_{25/100}$	$R_2 = R_{25} \exp[B_{25/100}(1/T_2 - 1/(298,15 \text{ K}))]$		3433		K

5 Characteristics diagrams

Pressure drop in cooling circuit, Package

$$\Delta p = f(\Delta V/\Delta t)$$

$T_f = 60\text{ °C}$, fluid = 50% water/50% ethylenglycol

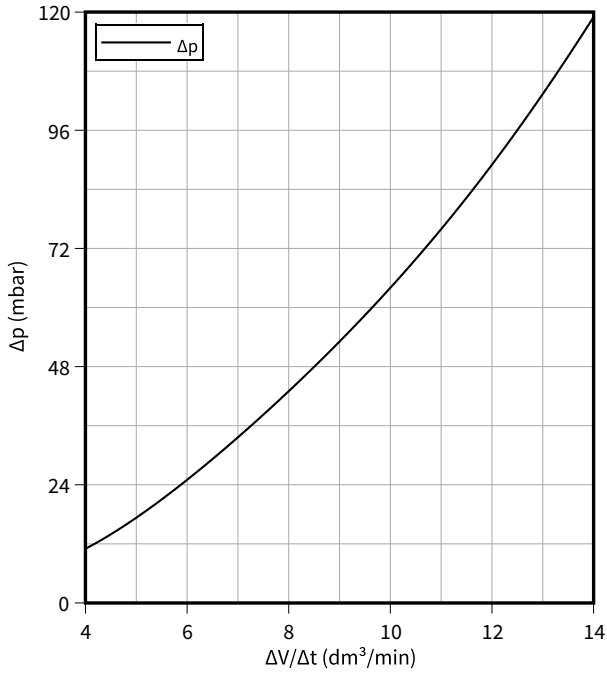

Output characteristic (typical), MOSFET

$$I_D = f(V_{DS})$$

$V_{GS} = 15\text{ V}$

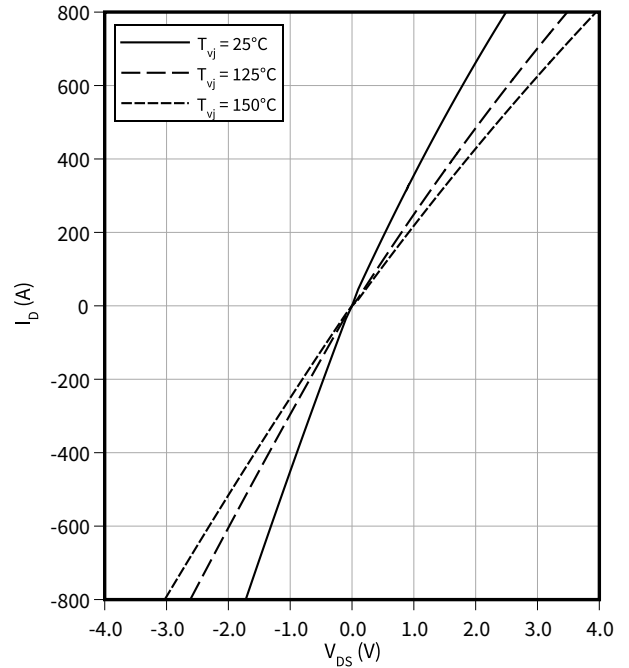

Output characteristic (typical), MOSFET

$$I_D = f(V_{DS})$$

$T_{vj} = 125\text{ °C}$

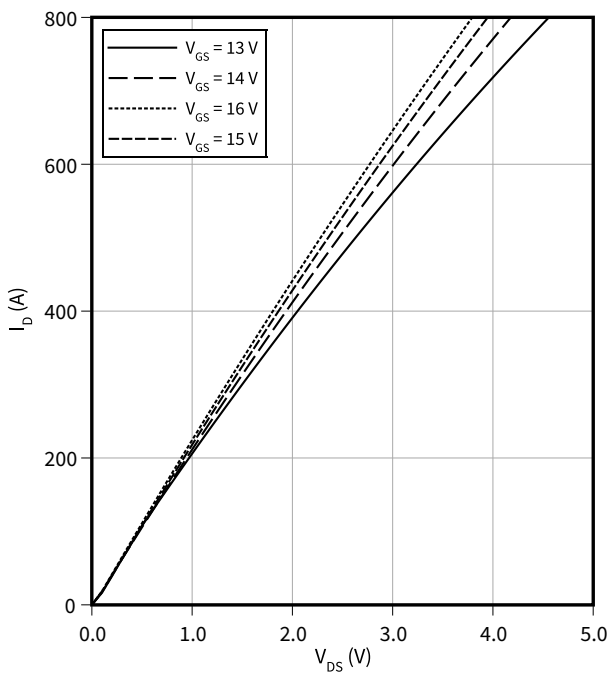

Transfer characteristic (typical), MOSFET

$$I_D = f(V_{GS})$$

$V_{DS} = 20\text{ V}$

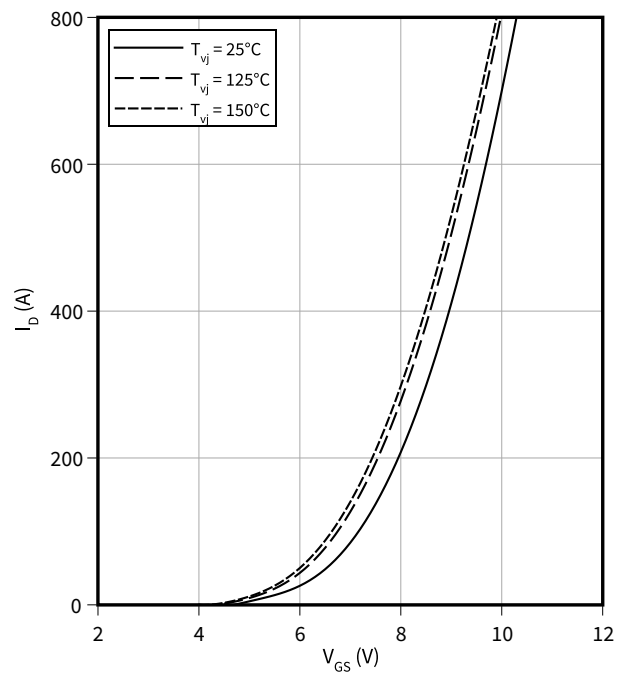

5 Characteristics diagrams

Drain-source on-resistance (typical), MOSFET

$R_{DS,on} = f(I_D)$
 $V_{GS} = 15\text{ V}$

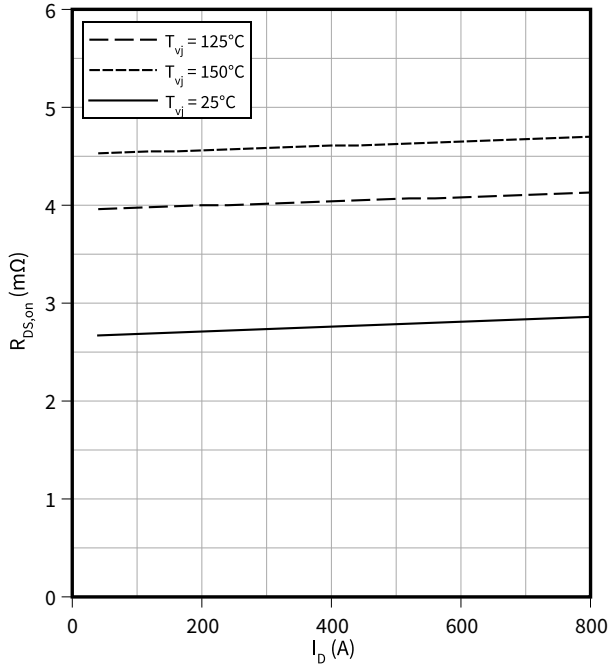

Drain-source on-resistance (typical), MOSFET

$R_{DS,on} = f(T_{vj})$
 $I_D = 400\text{ A}, V_{GS} = 15\text{ V}$

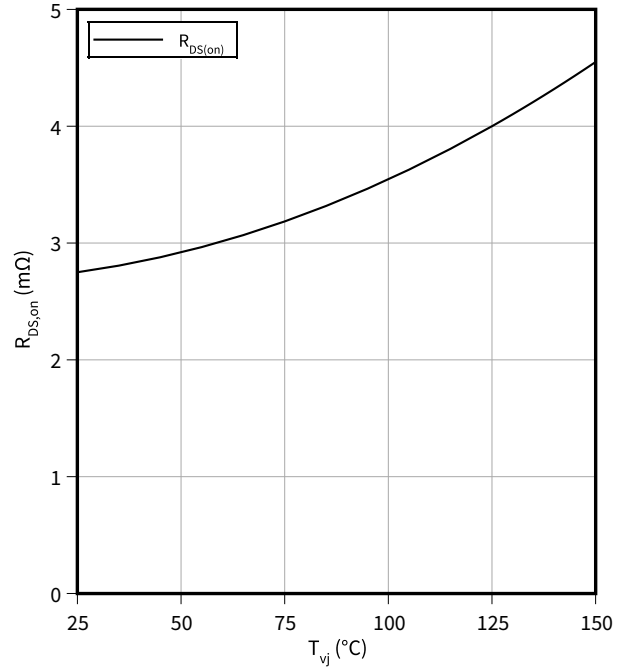

Maximum allowed drain-source voltage, MOSFET

$V_{DSS} = f(T_{vj})$

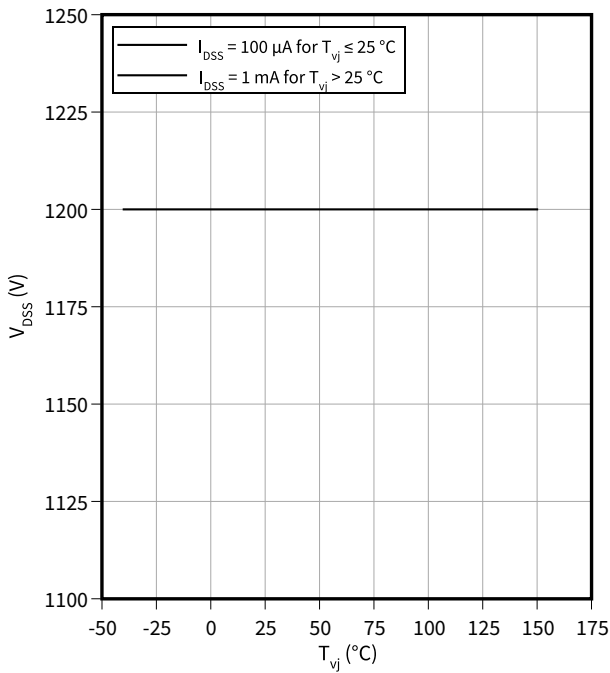

Capacity characteristic (typical), MOSFET

$C = f(V_{DS})$
 $T_{vj} = 25^\circ\text{C}, f = 1\text{ MHz}, V_{GS} = 0\text{ V}$

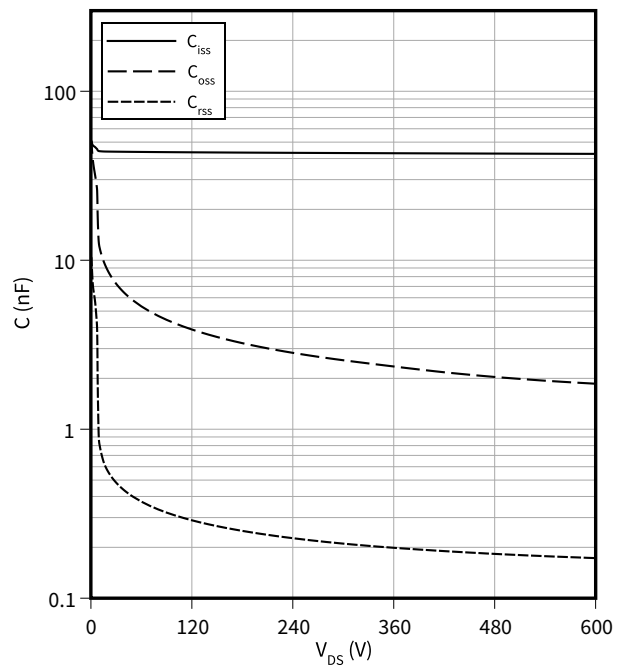

5 Characteristics diagrams

Switching losses (typical), MOSFET

$E = f(R_G)$

$I_D = 400 \text{ A}$, $V_{DS} = 600 \text{ V}$, $V_{GS} = -5/15 \text{ V}$

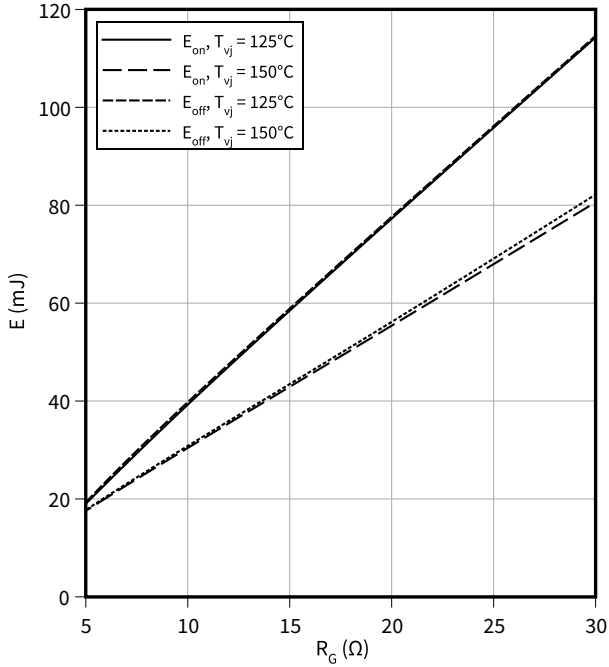

Switching losses (typical), MOSFET

$E = f(I_D)$

$V_{DS} = 600 \text{ V}$, $R_{G,off} = 5.1 \Omega$, $R_{G,on} = 5.1 \Omega$, $V_{GS} = -5/15 \text{ V}$

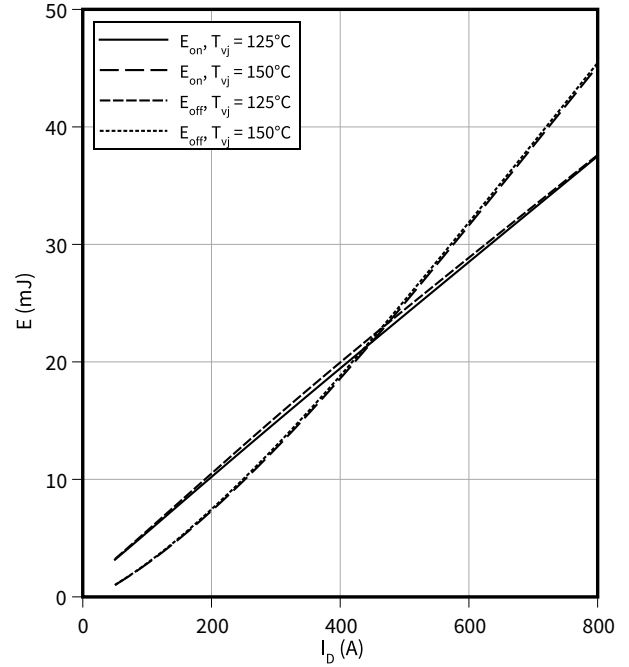

Reverse bias safe operating area (RBSOA), MOSFET

$I_D = f(V_{DS})$

$R_{G,off} = 5.1 \Omega$, $V_{GS} = +15/-5 \text{ V}$, $T_{vj} = 150 \text{ °C}$

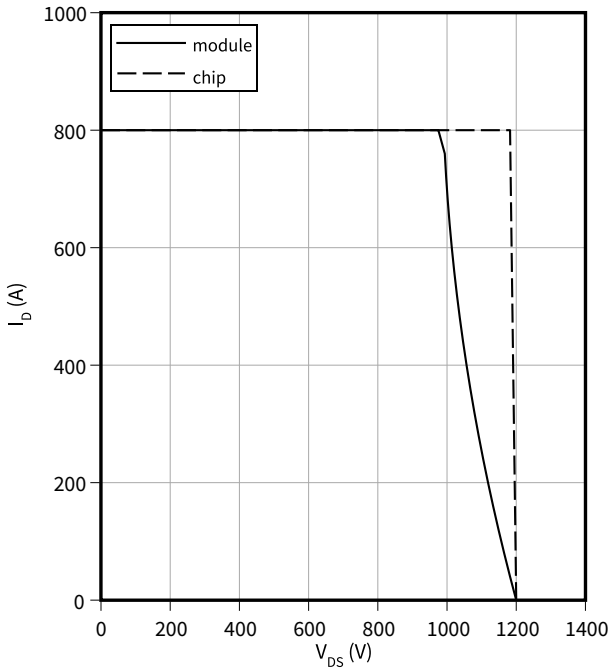

Thermal impedance , MOSFET

$R_{th,j-f} = f(dv/dt)$

fluid = 50% water/50% ethylenglycol , $T_f = 60 \text{ °C}$

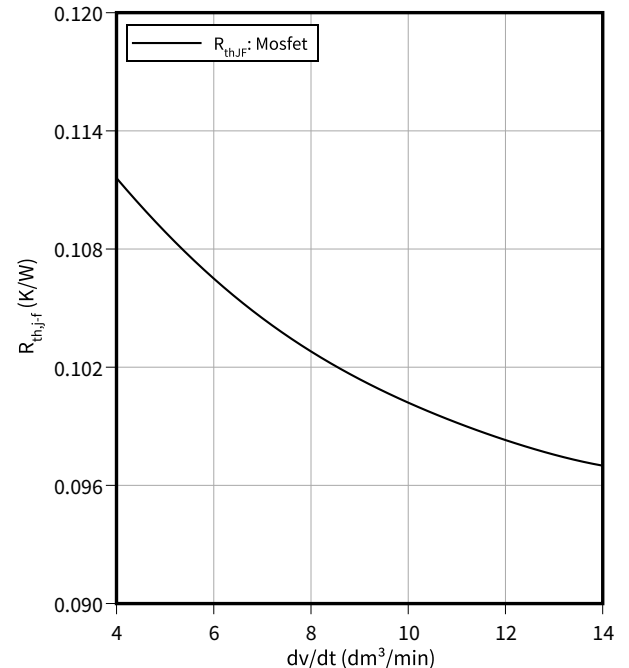

5 Characteristics diagrams

Transient thermal impedance, MOSFET

$Z_{th} = f(t)$

$\Delta V/\Delta t = 10 \text{ dm}^3/\text{min}$, fluid = 50% water/50% ethylenglycol, $T_f = 60 \text{ }^\circ\text{C}$

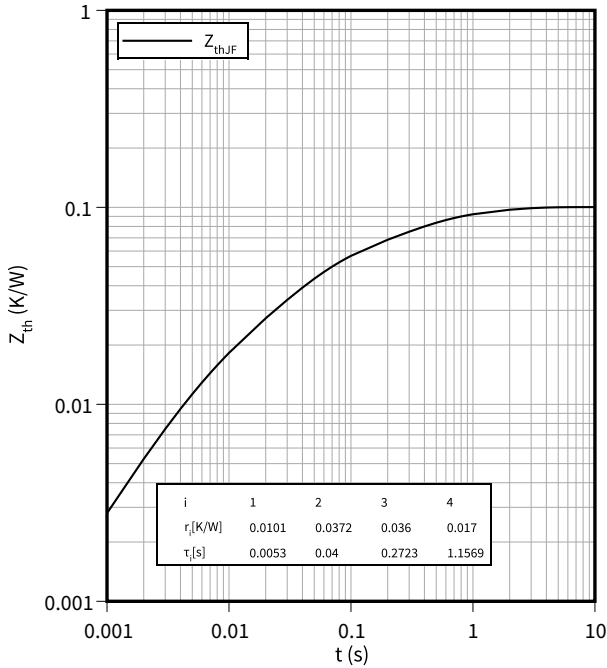

Forward characteristic body diode (typical), MOSFET

$I_{F,S} = f(V_{SD})$

$T_{vj} = 25 \text{ }^\circ\text{C}$

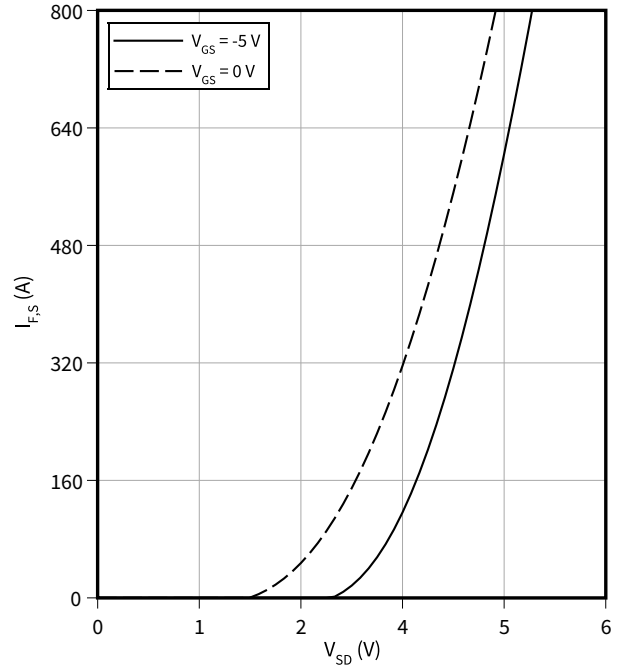

Switching losses body diode (typical), MOSFET

$E_{rec} = f(I_{SD})$

$V_r = 600 \text{ V}$, $R_{G,on} = 5.1 \text{ } \Omega$, $V_{GS} = -5/15 \text{ V}$

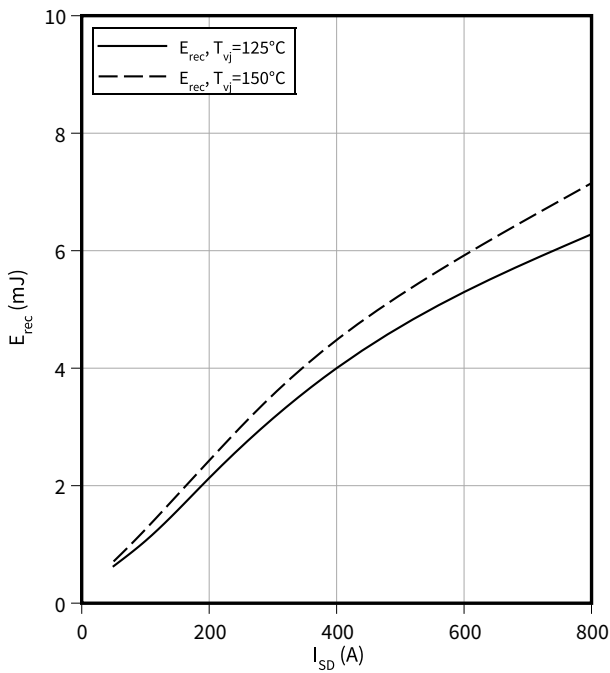

Switching losses body diode (typical), MOSFET

$E_{rec} = f(R_G)$

$V_r = 600 \text{ V}$, $I_{F,S} = 400 \text{ A}$, $V_{GS} = -5/15 \text{ V}$

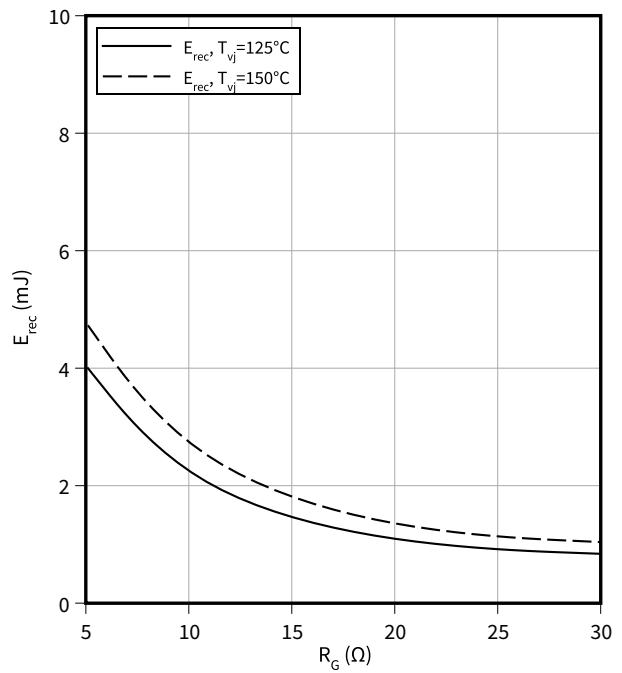

Temperature characteristic (typical), NTC-Thermistor

$R = f(T_{NTC})$

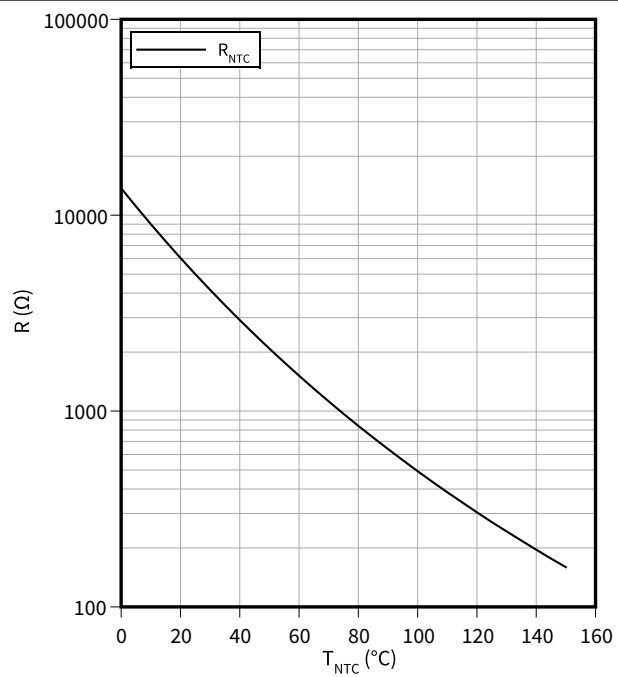

6 Circuit diagram

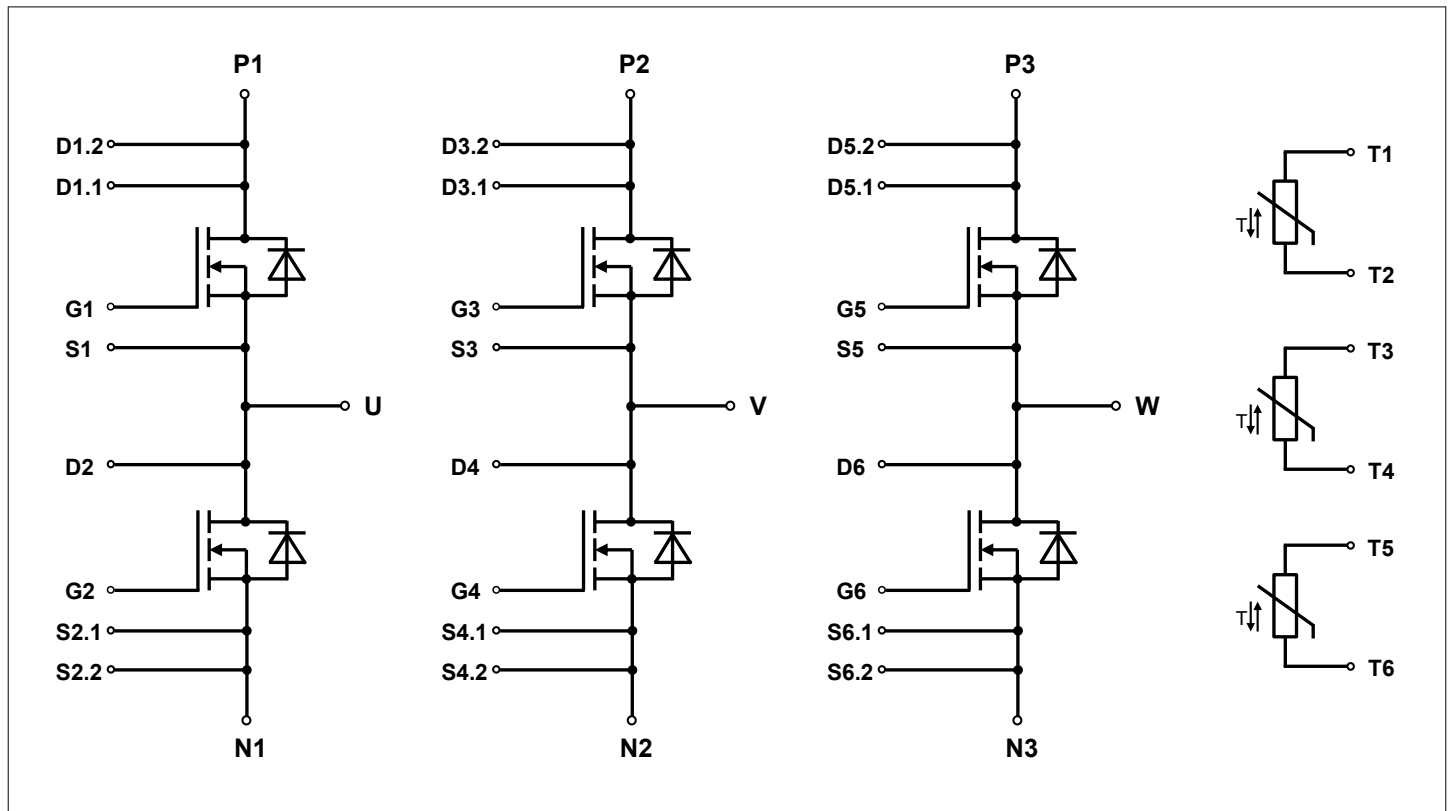

Figure 1

7 Package outlines

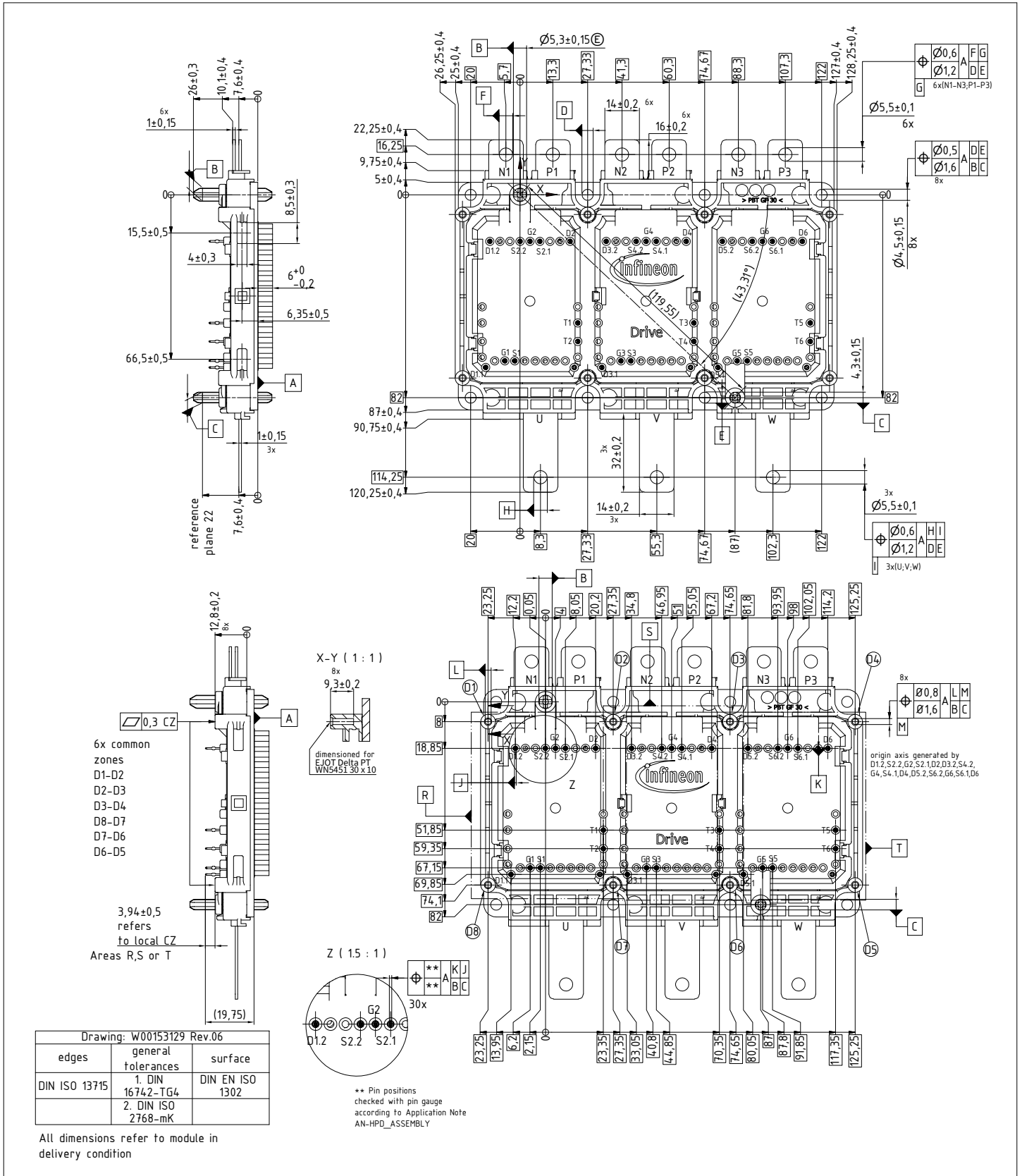

Figure 2

8 Module label code



Module label code				
Code format	Data Matrix	Barcode Code128		
Encoding	ASCII text	Code Set A		
Symbol size	16x16	23 digits		
Standard	IEC24720 and IEC16022	IEC8859-1		
Code content	<i>Content</i>	<i>Digit</i>	<i>Example</i>	
	Module serial number	1 - 5	71549	
	Module material number	6 - 11	142846	
	Production order number	12 - 19	55054991	
	Date code (production year)	20 - 21	15	
	Date code (production week)	22 - 23	30	
Example				
	71549142846550549911530		71549142846550549911530	
Packing label code				
Code format	Barcode Code128			
Encoding	Code Set A			
Symbol size	34 digits			
Standard	IEC8859-1			
Code content	<i>Content</i>	<i>Identifier</i>	<i>Digit</i>	<i>Example</i>
	Module serial number	X	2 - 9	95056609
	Module material number	1T	12 - 19	2X0003E0
	Production order number	S	21 - 25	754389
	Date code (production year)	9D	28 - 31	1139
	Date code (production week)	Q	33 - 34	15
Example				
	X950566091T2X0003E0S754389D1139Q15			

Figure 3

Revision history

Document revision	Date of release	Description of changes
V1.0	2019-09-03	Target datasheet
V2.0	2021-01-26	Preliminary datasheet
n/a	2020-10-05	Datasheet migrated to a new system with a new layout and new revision number schema: target or preliminary datasheet = 0.xy; final datasheet = 1.xy
1.00	2021-03-23	Final datasheet
1.10	2022-07-19	Adaption of product identification Adding electrical feature diagram Correction of typos