

Future Technology Devices International Ltd

FT2233HP/FT2232HP



(High Speed USB Bridge with Type-C/PD3.0 Controller)

The FT2233HP/FT2232HP is a Hi-Speed USB device with a Type-C/PD 3.0 controller that fully supports the latest USB Type-C and Power Delivery (PD) standards enabling support for power negotiation with the ability to sink or source current to a USB host device. The USB bridge function delivers 2 independent channels compatible with the existing FT2232H – Dual Hi-speed USB to multipurpose UART/MPSSE solution.

The FT2233HP/FT2232HP has the following advanced features:

- Supports the USBPD specification Rev 3.0.
- Port 1 mode configuration for Sink or Dual-role
- Port 2 works as Sink, supporting charge through to port1 (FT2233HPQ and FT2233HPL only)
- Supports 5V3A, 9V3A, 12V3A, 15V3A and 20V3A PDOs as sink or source
- Type-C/PD Physical Layer Protocol
- PD policy engine using 32-bit RISC controller with 8kB data RAM and 48kB code ROM
- PD mode configuration through external EEPROM
- Options to use external MCU controlling PD policy through I2C interface
- USB to dual serial ports with a variety of configurations.
- USB to dual FIFO ports available in Asynchronous FIFO mode, or one USB to Synchronous FIFO port. Enabled by external EEPROM settings.
- USB to parallel FIFO transfer data rate up to 8Mbytes/sec
- Single channel synchronous FIFO mode for transfer up to 40Mbytes/sec.
- Entire USB protocol handled on the chip. No USB specific firmware programming required.
- USB 2.0 High Speed (480Mbits/Second) and Full Speed (12Mbits/Second) compatible.
- Two Multi-Protocol Synchronous Serial Engine (MPSSE) on channel A and channel B, to simplify synchronous serial protocol (USB to JTAG, I²C, SPI or bit-bang) design.
- Independent Baud rate generators.
- RS232/RS422/RS485 UART Transfer Data Rate up to 12Mbaud. (RS232 Data Rate limited by external level shifter).
- FTDI's royalty-free Virtual Com Port (VCP) and Direct (D2XX) drivers eliminate the requirement for USB driver development in most cases.
- CPU-style FIFO interface mode simplifies CPU interface design.
- Fast Opto-Isolated serial interface option
- MCU host bus emulation mode configuration option
- Optional traffic TX/RX indicators can be added with LEDs.
- Adjustable receive buffer timeout.
- Support for USB suspend and resume conditions via PWREN#, SUSPEND# and RI# pins.
- FTDI FT232R/FT-X style, asynchronous serial UART interface option with full hardware handshaking and modem interface signals.
- Fully assisted hardware or X-On / X-Off software handshaking.
- UART Interface supports 7/8-bit data, ½ stop bits, and Odd/Even/Mark/Space/No Parity.
- Auto-transmit enable control for RS485 serial applications using TXDEN pin.
- Operational configuration mode and USB Description strings configurable in external EEPROM over the USB interface.
- Low operating and USB suspend current.
- UHCI/OCHI/EHCI host controller compatible
- Configurable I/O drive strength (4, 8, 12 or 16mA) and slew rate.
- USB Bulk data transfer mode (512-byte packets in High-Speed mode).
- Dedicated Windows/Linux DLLs available for USB to SPI, and USB to I²C applications.
- +3.3V single supply operating voltage range.
- +1.2V (chip core) and +3.3V I/O interfacing (+5V Tolerant).
- Highly integrated design includes +1.2V LDO regulator for VCORE, integrated POR function and on chip clock multiplier PLL (12MHz – 480MHz).
- Extended -40°C to 85°C industrial operating temperature range.
- Available in Pb-free QFN-76/QFN-68/LQFP-80 package (RoHS compliant)

1 Typical Applications

- USB bridge with Type-C/PD (chargers and devices)
- Up to 60W power delivery via USB PD and/or Type-C port
- Get power from USB device functions, e.g., portable USB host needs charging when USB is connected.
- Single chip USB to two channels UART (RS232, RS422 or RS485) or Bit-Bang interfaces.
- Single chip USB to two Asynchronous FIFO channels or one Synchronous FIFO channel.
- Single chip USB to two JTAG channels
- Single chip USB to one JTAG channel and one UART.
- Single chip USB to one SPI channel and one UART.
- Single chip USB to two SPI channels.
- Single chip USB to one SPI channel and one JTAG channel.
- Single chip USB to two I²C channels.
- Numerous combinations of two channels.
- Upgrading Legacy Peripheral Designs to USB
- Field Upgradable USB Products
- Cellular and cordless phone USB data transfer cables and interfaces.
- Interfacing MCU / PLD / FPGA based designs to USB
- PDA to USB data transfer
- USB Smart Card Readers
- USB Instrumentation
- USB Industrial Control
- USB FLASH Card Reader / Writers
- Set Top Box PC – USB interface
- USB Digital Camera Interface
- USB Bar Code Readers

1.1 Driver Support

The FT2233HP/FT2232HP requires USB drivers (listed below), available for free at <https://ftdichip.com/>, which are used to make the FT2233HP/FT2232HP appear as a virtual COM port (VCP). This allows the user to communicate with the USB interface via a standard PC serial emulation port (for example TTY). Another FTDI USB driver, the D2XX driver, can also be used with application software to directly access the FT2233HP/FT2232HP through a DLL.

Royalty free VIRTUAL COM PORT (VCP) DRIVERS for...

- Windows 10 32,64-bit
- Windows 8/8.1 32,64-bit
- Windows 7 32,64-bit
- Windows Server 2008 and server 2012 R2
- Mac OS-X
- Linux 2.4 and greater

Royalty free D2XX Direct Drivers (USB Drivers + DLL S/W Interface)

- Windows 10 32,64-bit
- Windows 8/8.1 32,64-bit
- Windows 7 32,64-bit
- Windows Server 2008 and server 2012 R2
- Mac OS-X
- Linux 2.4 and greater
- Android(J2xx)

For driver installation, please refer to the installation guides on our website:

<https://ftdichip.com/document/installation-guides/>

The following additional installation guides application notes and technical notes are also available:

- [AN_113 – Interfacing FT2232H Hi-Speed Devices To I2C Bus](#)
- [AN_114 – Interfacing FT2232H Hi-Speed Devices To SPI Bus](#)
- [AN_177 – User Guide For libMPSSE – I2C](#)
- [AN_110 – Programmers Guide for High Speed FTCJTAG DLL](#)
- [AN_178 – User Guide For libMPSSE – SPI](#)
- [AN_135 – MPSSE Basics](#)
- [AN_108 – Command Processor For MPSSE and MCU Host Bus Emulation Modes](#)
- [AN_411 – FTx232H MPSSE I2C Master Example in C#](#)
- [TN_104 – Guide to Debugging Customers Failed Driver Installation](#)
- [AN_448 – FT4233HP FT2233HP FT233HP Configuration Guide](#)
- [AN_551 – FT4232HP FT2232HP FT232HP Configuration Guide](#)

1.2 Part Numbers

Part Number	Package	Packing
FT2232HPQ-TRAY	QFN 68	260 pieces per tray
FT2232HPQ-REEL	QFN 68	3,000 pieces per reel
FT2233HPQ-TRAY	QFN 76	260 pieces per tray
FT2233HPQ-REEL	QFN 76	3,000 pieces per reel
FT2233HPL-TRAY	LQFP 80	Not yet available
FT2233HPL-REEL	LQFP 80	Not yet available

Please refer to [Section 6](#) for all the package mechanical parameters.

1.3 USB Compliant

The FT2233HP/FT2232HP is fully compliant with the USB 2.0 specification and the USB PD 3.0 specification. It has been given the USB-IF Test-ID 4282* for FT2233HP/6243 for FT2232HP*.

* For PD port1

The timing of the rise/fall time of the USB signals not only depends on the USB signal drivers, but it is also dependent on system and is affected by factors such as PCB layout, external components, and any transient protection present on the USB signals. For USB compliance these may require a slight adjustment. Timing can also be changed by adding appropriate passive components to the USB signals.



2 FT2233HP Block Diagram

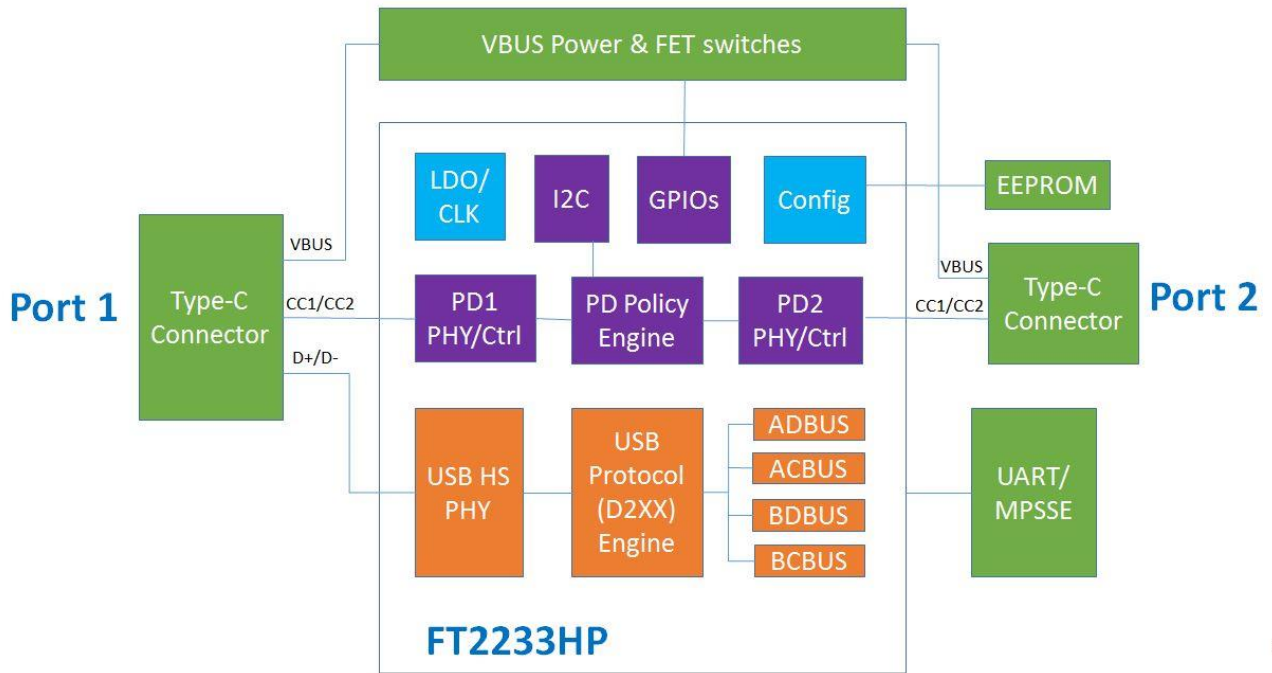

Figure 1 – FT2233HP Block Diagram

For a description of each function please refer to [Section 4](#).

Note: FT2232HP does not include Port 2.

Table of Contents

1 Typical Applications	2
1.1 Driver Support	2
1.2 Part Numbers.....	3
1.3 USB Compliant	3
2 FT2233HP Block Diagram	4
3 Device Pin Out and Signal Description.....	7
3.1 QFN–76 Package Pin Out	7
3.2 QFN–68 Package Pin Out	8
3.3 LQFP–80 Package Pin Out.....	9
3.4 Pin Description	10
3.5 Common Pins	11
3.6 Configured Pins.....	13
4 Function Description	19
4.1 Key Features	19
4.2 Functional Block Descriptions	19
4.3 FT232 UART Interface Mode Description.....	21
4.4 FT245 Synchronous FIFO Interface Mode Description.....	23
4.5 FT245 Asynchronous FIFO Interface Mode Description.....	25
4.6 MPSSE Interface Mode Description	26
4.7 MCU Host Bus Emulation Mode.....	28
4.8 Fast Opto-Isolated Serial Interface Mode Description.....	30
4.9 CPU-Style FIFO Interface Mode Description.....	33
4.10 Synchronous and Asynchronous Bit-Bang Interface Mode.....	34
4.11 RS232 UART Mode LED Interface Description	36
4.12 Send Immediate / Wake Up (SIWU#)	37
4.13 FT2233HP/FT2232HP Mode Selection.....	37
4.14 USB Type-C/PD Controller	38
5 Devices Characteristics and Ratings.....	41
5.1 Absolute Maximum Ratings.....	41
5.2 DC Characteristics.....	41
5.3 ESD Tolerance.....	43
6 Package Parameters	44

6.1 FT2233HPL, LQFP-80 Package Dimensions	44
6.2 FT2233HPQ, QFN-76 Package Dimensions	45
6.3 FT2232HPQ, QFN-68 Package Dimensions	46
7 FT2233HP/FT2232HP Configuration	47
7.1 Oscillator Configuration	47
7.2 PD Configuration.....	48
8 EEPROM Configuration	49
8.1 Default EEPROM Configuration.....	49
8.2 PD Configuration and Default values.....	50
9 Contact Information.....	51
Appendix A – References	52
Document References.....	52
Acronyms and Abbreviations	52
Appendix B – List of Tables and Figures.....	53
List of Tables	53
List of Figures.....	54
Appendix C – Revision History	55

3 Device Pin Out and Signal Description

3.1 QFN-76 Package Pin Out

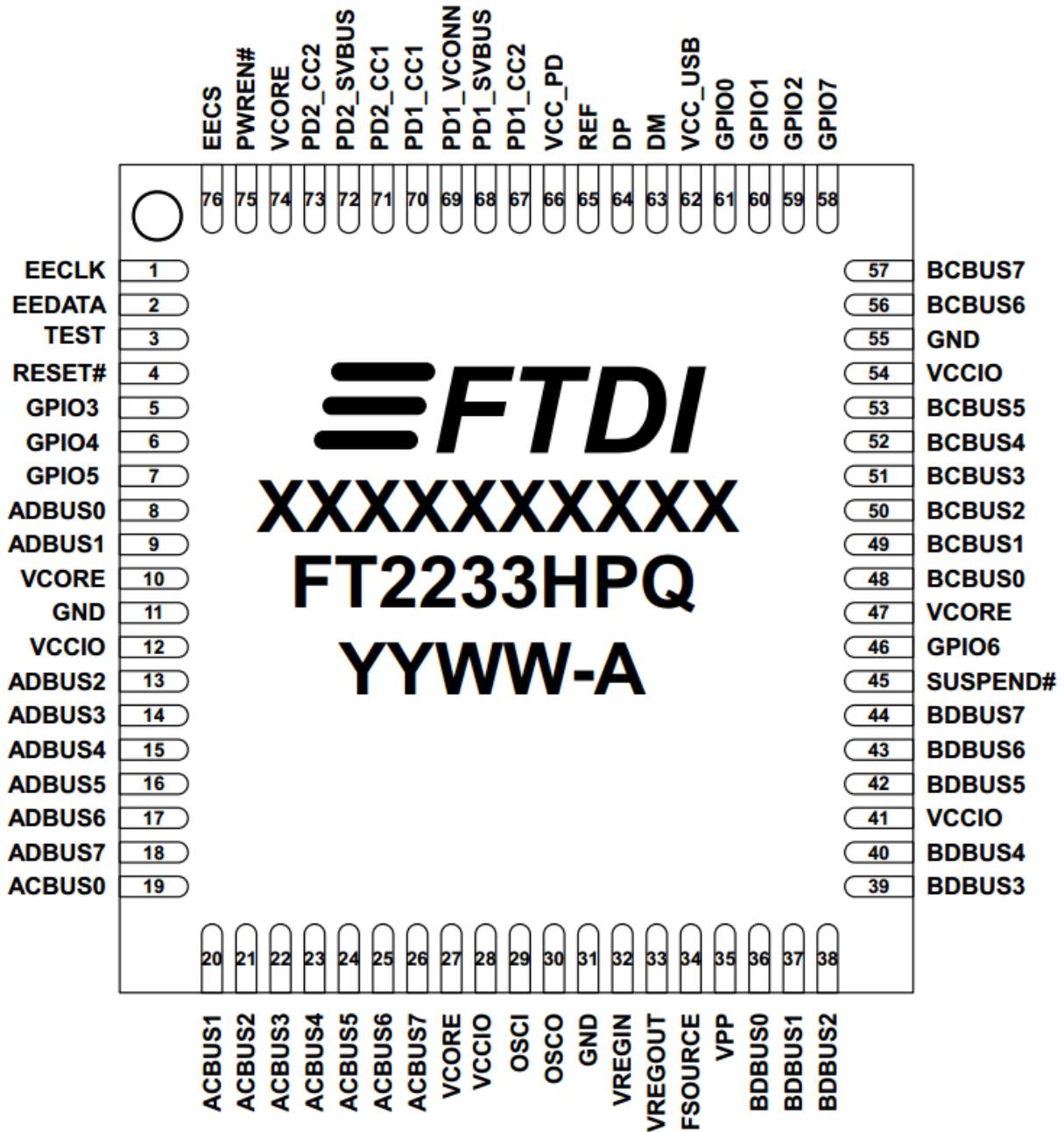

Figure 2 – Pin Configuration QFN-76 (Top View)

3.2 QFN-68 Package Pin Out

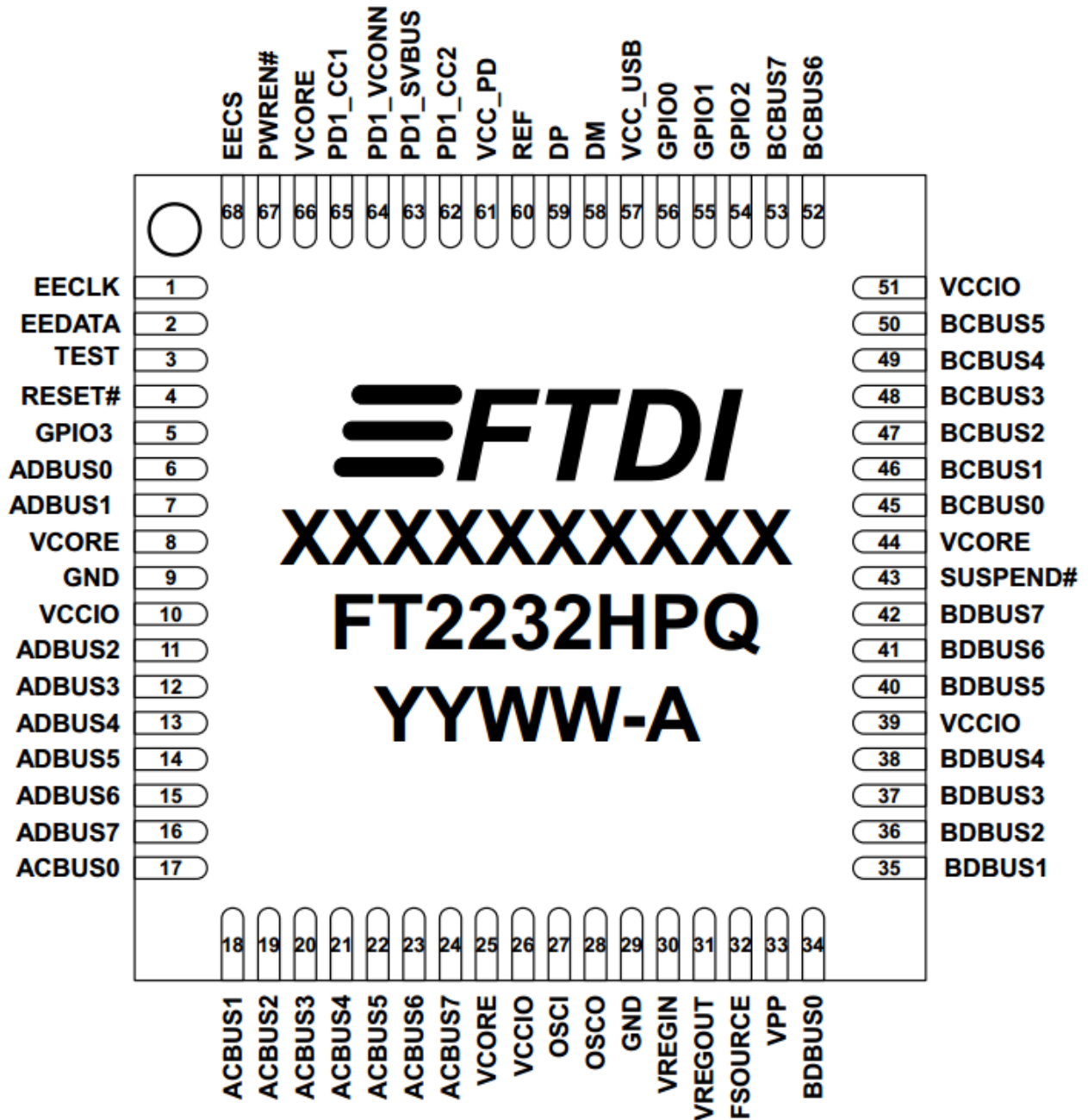

Figure 3 - Pin Configuration QFN-68 (Top View)

3.3 LQFP-80 Package Pin Out

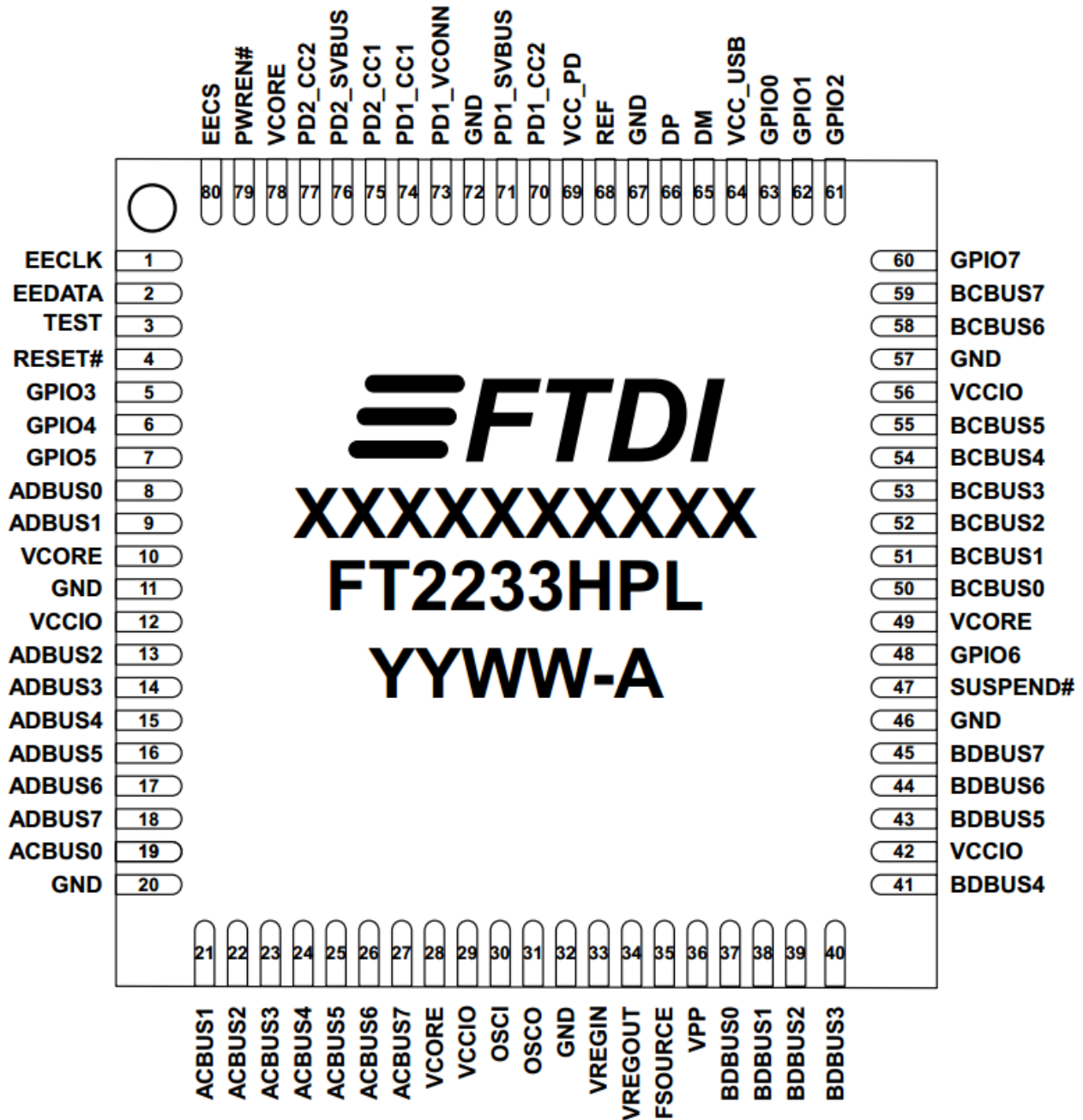

Figure 4 - Pin Configuration LQFN-80 (Top View)

3.4 Pin Description

This section describes the operation of the FT2233HP/FT2232HP pins. The function of many of the pins is determined by the configuration of the FT2233HP/FT2232HP. The following table details the function of each pin dependent on the configuration of the interface. Each of the functions are described in Table 1.

Note: The convention used throughout this document for active low signals is the signal name followed by #.

FT2233HP/FT2232HP												
Pins#				Pin functions (depend on configuration)								
QFN68	QFN76	LQFP80	Pin Name	ASYNCSerial UART (RS232/422/485)	245FIFOSYNC	245FIFO	ASYNCCBit-bang	SYNCCBit-bang	MPSSE	Fast Serial interface	CPU Style FIFO	Host Bus Emulation
Channel A												
6	8	8	ADBUS0	TXD	D0	D0	D0	D0	TCK/SK		D0	AD0
7	9	9	ADBUS1	RXD	D1	D1	D1	D1	TDI/DO		D1	AD1
11	13	13	ADBUS2	RTS#	D2	D2	D2	D2	TDO/DI		D2	AD2
12	14	14	ADBUS3	CTS#	D3	D3	D3	D3	TMS/CS		D3	AD3
13	15	15	ADBUS4	DTR#	D4	D4	D4	D4	GPIO L0		D4	AD4
14	16	16	ADBUS5	DSR#	D5	D5	D5	D5	GPIO L1		D5	AD5
15	17	17	ADBUS6	DCD#	D6	D6	D6	D6	GPIO L2		D6	AD6
16	18	18	ADBUS7	RI#	D7	D7	D7	D7	GPIO L3		D7	AD7
17	19	19	ACBUS0	TXDEN	RXF#	RXF#	**	**	GPIO H0		CS#	I/O0
18	20	21	ACBUS1	**	TXE#	TXE#	WRSTB#	WRSTB#	GPIO H1		A0	I/O1
19	21	22	ACBUS2	**	RD#	RD#	RDSTB#	RDSTB#	GPIO H2		RD#	IORDY
20	22	23	ACBUS3	RXLED#	WR#	WR#	**	**	GPIO H3		WR#	CLKOUT
21	23	24	ACBUS4	TXLED#	SIWUA	SIWUA	SIWUA	SIWUA	GPIO H4	SIWUA	Note1	**
22	24	25	ACBUS5	**	CLKOUT	**	**	**	GPIO H5		**	**
23	25	26	ACBUS6	**	OE#	**	**	**	GPIO H6		**	**
24	26	27	ACBUS7	**	**	**	**	**	GPIO H7		**	**
Channel B												
34	36	37	BDBUS0	TXD		D0	D0	D0	TCK/SK	FSDI	D0	AD8
35	37	38	BDBUS1	RXD		D1	D1	D1	TDI/DO	FSCLK	D1	AD9
36	38	39	BDBUS2	RTS#		D2	D2	D2	TDO/DI	FSDO	D2	AD10
37	39	40	BDBUS3	CTS#		D3	D3	D3	TMS/CS	FSCTS	D3	AD11
38	40	41	BDBUS4	DTR#		D4	D4	D4	GPIO L0		D4	AD12

40	42	43	BDBUS5	DSR#		D5	D5	D5	GPIO L1		D5	AD13
41	43	44	BDBUS6	DCD#		D6	D6	D6	GPIO L2		D6	AD14
42	44	45	BDBUS7	RI#		D7	D7	D7	GPIO L3		D7	AD15
45	48	50	BCBUS0	TXDEN		RXF#	**	**	GPIO H0		CS#	CS#
46	49	51	BCBUS1	**		TXE#	WRST B#	WRSTB #	GPIO H1		A0	ALE
47	50	52	BCBUS2	**		RD#	RDST B#	RDSTB #	GPIO H2		RD#	RD#
48	51	53	BCBUS3	RXLED#		WR#	**	**	GPIO H3		WR#	WR#
49	52	54	BCBUS4	TXLED#		SIWU B	SIWU B	SIWUB	GPIO H4	SIWU B	Note1	**
50	53	55	BCBUS5	**		**	**	**	GPIO H5		**	**
52	56	58	BCBUS6	**		**	**	**	GPIO H6		**	**
53	57	59	BCBUS7	PWRSV #	PWRS AV#	PWRS AV#	PWRS AV#	PWRSV #	GPIO H7	PWRS AV#	PWRSV #	PWRS AV#
67	75	79	PWREN#	PWREN#	PWRE N#	PWRE N#	PWRE N#	PWREN #	PWRE EN#	PWRE N#	PWREN #	PWRE N#
43	45	47	SUSPEND #	SUSPEND#	SUSPEND#	SUSPEND#	SUSPEND#	SUSPEND#	SUSPEND #	SUSPEND#	SUSPEND#	SUSPEND#

Table 1 – FT2233HP/FT2232HP Pin Description

Pins marked ** default to tri-stated inputs with an internal 75KΩ (11chottk.) pull up resistor to VCCIO.

Note 1: Initial Pin States – The device will always start up as two UART ports. Therefore, pins which are output in UART mode will be driving out. If an application uses MPSSE or bit-bang, ensure that any external signals do not drive into these pins and cause contention until the application has configured the mode and direction of these lines.

Note 2: To wake up the USB device in this mode, put ACBUS0 from “High” to “LOW”, set ACBUS1 “High”, and put ACBUS3 from “High” to “LOW”. The same also applies on the equivalent Channel B pins

3.5 Common Pins

The operation of the following FT2233HP/FT2232HP pins are the same regardless of the configured mode:-

FT2233HP/FT2232HP					
QFN-68	QFN-76	LQFP-80	Name	Type	Description
8,25,44,66	10,27,47,74	10,28,49,78	VCORE	POWER Input	+1.2V input. Core supply voltage input. Connect to VREGOUT when using internal regulator.
10,26,39,51,	12,28,41,54	12,29,42,56	VCCIO	POWER Input	+3.3V input. I/O interface power supply input. Failure to connect all VCCIO pins will result in failure of the device.
57	62	64	VCC_USB	POWER Input	+3.3V Input. Internal USB PHY power supply input. Note that this cannot be connected directly to the USB supply. A +3.3V regulator must be used. It is recommended that this supply is filtered using an LC filter.
61	66	69	VCC_PD	POWER Input	+3.3V Input. Internal PD PHY power supply input.
30	32	33	VREGIN	POWER Input	+3.3V Input. Integrated 1.2V voltage regulator input.
31	33	34	VREGOUT	POWER Output	+1.2V Output. Integrated voltage regulator output. Connect to VCORE with 3.3uF filter

					capacitor. This output should not be used to power other circuits apart from VCORE.
32	34	35	FSOURCE	POWER Input	FSOURCE input pin for EFUSE. Leave floating for normal operation
33	35	36	VPP	POWER Input	VPP input pin for EFUSE. Leave floating for normal operation
9,29	11, 31, 55	11,20,32,46,57,67	GND	POWER Input	Ground.

Table 2 – Power and Ground Pins

FT2233HP/FT2232HP					
QFN-68	QFN-76	LQFP-80	Name	Type	Description
27	29	30	OSCI	INPUT	Oscillator input.
28	30	31	OSCO	OUTPUT	Oscillator output.
60	65	68	REF	INPUT	Current reference – connect via a 12K Ohm resistor @ 1% to GND.
58	63	65	DM	I/O	USB Data Signal Minus.
59	64	66	DP	I/O	USB Data Signal Plus.
3	3	3	TEST	INPUT	IC test pin – for normal operation should be connected to GND.
4	4	4	RESET#	INPUT	Reset input (active low).
67	75	79	PWREN#	OUTPUT	Active low power-enable output. PWREN# = 0: Normal operation. PWREN# = 1: USB SUSPEND mode or device has not been configured. This can be used by external circuitry to power down logic when device is in USB suspend or has not been configured.
43	45	47	SUSPEND#	OUTPUT	Active low when USB is in suspend mode.

Table 3 – Common Function Pins

FT2233HP/FT2232HP					
QFN-68	QFN-76	LQFP-80	Name	Type	Description
68	76	80	EECS*	I/O	EEPROM – Chip Select. Tri-State during device reset.
1	1	1	EECLK*	OUTPUT	Clock signal to EEPROM. Tri-State during device reset. When not in reset, this outputs the EEPROM clock.
2	2	2	EEDATA*	I/O	EEPROM – Data I/O Connect directly to Data-In of the EEPROM and to Data-Out of the EEPROM via a 2.2K resistor. Also, pull Data-Out of the EEPROM to VCC via a 10K resistor for correct operation. Tri-State during device reset.

Table 4 – EEPROM Interface Pins

*** Note:** Pull each of these pins via separate 10K resistor to VCCIO if no EEPROM used.

FT2233HP/FT2232HP					
QFN-68	QFN-76	LQFP-80	Name	Type	Description
63	68	71	PD1_SVBUS	AI	Analog input. Scaled down VBUS sensing input for PD1. VBUS is required to be scaled down between 7.5 and 7.7 before input to this pin.
64	69	73	PD1_VCONN	Power Input	Power input for PD1 VCONN power source. Connect to 3.3V.
65	70	74	PD1_CC1	AI/O	Analog IO pin. PD1 CC1 pin
62	67	70	PD1_CC2	AI/O	Analog IO pin. PD1 CC2 pin
-	72	76	PD2_SVBUS	AI	Analog input. Scaled down VBUS sensing input for PD2. VBUS is required to be scaled down between 7.5 and 7.7 before input to this pin.
-	71	75	PD2_CC1	AI/O	Analog IO pin. PD2 CC1 pin
-	73	77	PD2_CC2	AI/O	Analog IO pin. PD2 CC2 pin

Table 5 – Type-C/PD Port Pins

FT2233HP/FT2232HP					
QFN-68	QFN-76	LQFP-80	Name	Type	Description
56	61	63	GPIO0	I/O	GPIO0 or I2C_SDA pin. Default function is GPIO0 input with weak pull-down.
55	60	62	GPIO1	I/O	GPIO1 or I2C_SCL pin. Default function is GPIO1 input with weak pull-down.
54	59	61	GPIO2	I/O	GPIO2 or I2C_INT# pin. Default function is GPIO2 input with weak pull-down.
5	5	5	GPIO3	I/O	GPIO3 pin. Default function is GPIO3 input with weak pull-down.
-	6	6	GPIO4	I/O	GPIO4 pin. Default function is GPIO4 input with weak pull-down.
-	7	7	GPIO5	I/O	GPIO5 pin. Default function is GPIO5 input with weak pull-down.
-	46	48	GPIO6	I/O	GPIO6 pin. Default function is GPIO6 input with weak pull-down.
-	58	60	GPIO7	I/O	GPIO7 pin. Default function is GPIO7 input with weak pull-down.

Table 6 – GPIO Pins

3.6 Configured Pins

The following sections describe the function of the configurable pins referred to in Table 1. This is determined by how the FT2233HP/FT2232HP is configured.

3.6.1 FT2233HP/FT2232HP pins used in an RS232 Interface

The FT2233HP/FT2232HP channel A or channel B can be configured as an RS232 interface. When configured in this mode, the pins used, and the descriptions of the signals are shown in Table 7.

FT2233HP/FT2232HP								
Channel A Pin No.			Channel B Pin No.			Name	Type	RS232 Configuration Description
QFN-68	QFN-76	LQFP-80	QFN-68	QFN-76	LQFP-80			
6	8	8	34	36	37	TXD	OUTPUT	TXD = transmitter output
7	9	9	35	37	38	RXD	INPUT	RXD = receiver input
11	13	13	36	38	39	RTS#	OUTPUT	RTS# = Ready To send handshake output
12	14	14	37	39	40	CTS#	INPUT	CTS# = Clear To Send handshake input
13	15	15	38	40	41	DTR#	OUTPUT	DTR# = Data Transmit Ready modem signaling line
14	16	16	40	42	43	DSR#	INPUT	DSR# = Data Set Ready modem signaling line
15	17	17	41	43	44	DCD#	INPUT	DCD# = Data Carrier Detect modem signaling line
16	18	18	42	44	45	RI#	INPUT	RI# = Ring Indicator Control Input. When the Remote Wake-Up option is enabled in the EEPROM, taking RI# low can be used to resume the PC USB Host controller from suspend. (see note 1, 2 and 3)
17	19	19	45	48	50	TXDEN	OUTPUT	TXDEN = (TTL level). For use with RS485 level converters.
20	22	23	48	51	53	RXLED#	OUTPUT	RXLED = Receive signaling output when data is transferred from FT2233HP/FT2232HP to USB Host. Pulses low when receiving data (RXD) via USB. This should be connected to an LED.
21	23	24	49	52	54	TXLED#	OUTPUT	TXLED = Transmit signaling output when data is transferred from USB Host to FT2233HP. Pulses low when transmitting data (TXD) via USB. This should be connected to an LED.

Table 7 – Channel A & B RS232 Configured Pin Descriptions

Notes

1. When using remote wake-up, ensure the resistors are pulled-up in suspend. Also ensure peripheral designs do not allow any current sink paths that may partially power the peripheral.
2. A peripheral is allowed to draw up to 2.5mA in suspend.
3. If a Pull-down is enabled, the FT2233HP/FT2232HP will not wake up from suspend.

3.6.2 FT2233HP/FT2232HP pins used in an FT245 Style Synchronous FIFO Interface

The FT2233HP/FT2232HP only channel A can be configured as a FT245 style synchronous FIFO interface. When configured in this mode, the pins used, and the descriptions of the signals are shown in Table 8. To enter this mode the external EEPROM must be set to make port A 245 mode. A software command (Set Bit Mode option) is then sent by the application to the FTDI driver to tell the chip to enter single channel synchronous FIFO mode. In this mode the 'B' channel is not available as all resources have been switched onto channel A. In this mode, data is written or read on the rising edge of the CLKOUT.

FT2233HP/FT2232HP					
Channel A Pin No.			Name	Type	FT245 Configuration Description
QFN-68	QFN-76	LQFP-80			
6,7,11-16	8,9,13-18	8,9,13-18	ADBUS[7:0]	I/O	D7 to D0 bidirectional FIFO data. This bus is normally input unless OE# is low.
17	19	19	RXF#	OUTPUT	When high, do not read data from the FIFO. When low, there is data available in the FIFO which can be read by driving RD# low. When in synchronous mode, data is transferred on every clock that RXF# and RD# are both low. Note that the OE# pin must be driven low at least 1 clock period before asserting RD# low.
18	20	21	TXE#	OUTPUT	When high, do not write data into the FIFO. When low, data can be written into the FIFO by driving WR# low. When in synchronous mode, data is transferred on every clock that TXE# and WR# are both low.
19	21	22	RD#	INPUT	Enables the current FIFO data byte to be driven onto D0...D7 when RD# goes low. The next FIFO data byte (if available) is fetched from the receive FIFO buffer each CLKOUT cycle until RD# goes high.
20	22	23	WR#	INPUT	Enables the data byte on the D0...D7 pins to be written into the transmit FIFO buffer when WR# is low. The next FIFO data byte is written to the transmit FIFO buffer each CLKOUT cycle until WR# goes high.
22	24	25	CLKOUT	OUTPUT	60 MHz Clock driven from the chip. All signals should be synchronized to this clock.
23	25	26	OE#	INPUT	Output enables when low to drive data onto D0-7. This should be driven low at least 1 clock period before driving RD# low to allow for data buffer turn-around.
21	23	24	SIWU	INPUT	The Send Immediate / WakeUp signal combines two functions on a single pin. If USB is in suspend mode (PWREN# = 1) and remote wakeup is enabled in the EEPROM, strobing this pin low will cause the device to request a resume on the USB Bus. Normally, this can be used to wake up the Host PC. During normal operation (PWREN# = 0), if this pin is strobed low any data in the device TX buffer will be sent out over USB on the next Bulk-IN request from the drivers regardless of the pending packet size. This can be used to optimize USB transfer speed for some applications. Tie this pin to VCCIO if not used.

Table 8 – Channel A FT245 Style Synchronous FIFO Configured Pin Descriptions

3.6.3 FT2233HP/FT2232HP pins used in an FT245 Style Asynchronous FIFO Interface

The FT2233H/FT2232HP channel A or channel B can be configured as a FT245 asynchronous FIFO interface. When configured in this mode, the pins used, and the descriptions of the signals are shown in Table 9. To enter this mode the external EEPROM must be set to make port A or B or both 245 modes. In this mode, data is written or read on the falling edge of the RD# or WR# signals.

FT2233HP/FT2232HP								
Channel A Pin No.			Channel B Pin No.			Name	Type	FT245 Configuration Description
QFN-68	QFN-76	LQFP-80	QFN-68	QFN-76	LQFP-80			
6,7,11-16	8,9,13-18	8,9,13-18	34-38,40-42	36-40,42-44	37-41,43-45	Channel A = ADBUS[7:0] Channel B = BDBUS[7:0]	I/O	D7 to D0 bidirectional FIFO data. This bus is normally input unless RD# is low.
17	19	19	45	48	50	RXF#	OUTPUT	When high, do not read data from the FIFO. When low, there is data available in the FIFO which can be read by driving RD# low. When RD# goes high again RXF# will always go high and only become low again if there is another byte to read. During reset this signal pin is tri-state but pulled up to VCCIO via an internal 200kΩ resistor.
18	20	21	46	49	51	TXE#	OUTPUT	When high, do not write data into the FIFO. When low, data can be written into the FIFO by strobing WR# high, then low. During reset this signal pin is tri-state but pulled up to VCCIO via an internal 200kΩ resistor.
19	21	21	47	50	52	RD#	INPUT	Enables the current FIFO data byte to be driven onto D0...D7 when RD# goes low. Fetches the next FIFO data byte (if available) from the receive FIFO buffer when RD# goes high.
20	22	23	48	51	53	WR#	INPUT	Writes the data byte on the D0...D7 pins into the transmit FIFO buffer when WR# goes from high to low.
21	23	24	49	52	54	SIWU	INPUT	The Send Immediate / WakeUp signal combines two functions on a single pin. If USB is in suspend mode (PWREN# = 1) and remote wakeup is enabled in the EEPROM, strobing this pin low will cause the device to request a resume on the USB Bus. Normally, this can be used to wake up the Host PC. It should be pulled up to high level before strobing low. During normal operation (PWREN# = 0), if this pin is strobed low any data in the device TX buffer will be sent out over USB on the next Bulk-IN request from the drivers regardless of the pending packet size. This can be used to optimize USB transfer speed for some applications. Tie this pin to VCCIO if not used.

Table 9 – Channel A & B FT245 Style Asynchronous FIFO Configured Pin Descriptions

3.6.4 FT2233HP/FT2232HP pins used in a Synchronous or Asynchronous Bit-Bang Interface

The FT2233HP/FT2232HP channel A or channel B can be configured as a synchronous or asynchronous bit-bang interface. Bit-bang mode is a special FTDI FT2233HP/FT2232HP device mode that changes the 8 IO lines on either (or both) channels into an 8-bit bi-directional data bus. There are two types of bit-bang modes: synchronous and asynchronous.

When configured in any bit-bang mode, the pins used, and the descriptions of the signals are shown in Table 10.

FT2233HP/FT2232HP								
Channel A Pin No.			Channel B Pin No.			Name	Type	Configuration Description
QFN-68	QFN-76	LQFP-80	QFN-68	QFN-76	LQFP-80			
6,7,11-16	8,9,13-18	8,9,13-18	34-38,40-42	36-40,42-44	37-41,43-45	Channel A = ADBUS[7:0] Channel B = BDBUS[7:0]	I/O	D7 to D0 bidirectional Bit-Bang parallel I/O data pins
18	20	21	46	49	51	WRSTB#	OUTPUT	Write strobe, active low output indicates when new data has been written to the I/O pins from the Host PC (via the USB interface).
19	21	22	47	50	52	RDSTB#	OUTPUT	Read strobe, this output rising edge indicates when data has been read from the parallel I/O pins and sent to the Host PC (via the USB interface).
21	23	24	49	52	54	SIWU	INPUT	The Send Immediate / WakeUp signal combines two functions on a single pin. If USB is in suspend mode (PWREN# = 1) and remote wakeup is enabled in the EEPROM, strobing this pin low will cause the device to request a resume on the USB Bus. Normally, this can be used to wake up the Host PC. During normal operation (PWREN# = 0), if this pin is strobed low any data in the device TX buffer will be sent out over USB on the next Bulk-IN request from the drivers regardless of the pending packet size. This can be used to optimize USB transfer speed for some applications. Tie this pin to VCCIO if not used.

Table 10 – Channel A & B Synchronous or Asynchronous Bit-Bang Configured Pin Description

3.6.5 FT2233HP/FT2232HP Pins used as a Fast Serial Interface

The FT2233HP/FT2232HP channel B can be configured for use with high-speed optical bi-directional isolated serial data transfer: Fast Serial Interface. (Not available on channel A). A proprietary FTDI protocol designed to allow galvanic isolated devices to communicate synchronously with the FT2233HP/FT2232HP using just 4 signal wires (over two dual opto-isolators), and two power lines. The peripheral circuitry controls the data transfer rate in both directions, whilst maintaining full data integrity. Maximum USB full speed data rates can be achieved. Both 'A' and 'B' channels can communicate over the same 4 wire interface if desired.

When configured in this mode, the pins used, and the descriptions of the signals are shown in Table 11.

FT2233HP/FT2232HP					
Channel B Pin No.			Name	Type	Fast Serial Interface Configuration Description
QFN-68	QFN-76	LQFP-80			
34	36	37	FSDI	INPUT	Fast serial data input.
35	37	38	FSCLK	INPUT	Fast serial clock input. Clock input to FT2233HP/FT2232HP chip to clock data in or out.
36	38	39	FSDO	OUTPUT	Fast serial data output.
37	39	40	FSCTS	OUTPUT	Fast serial Clear To Send signal output. Driven low to indicate that the chip is ready to send data

Table 11 – Channel B Fast Series Interface Configured Pin Descriptions

3.6.6 FT2233HP/FT2232HP Pins Configured as a CPU-style FIFO Interface

The FT2233HP/FT2232HP channel A or channel B can be configured in a CPU-style FIFO interface mode which allows a CPU to interface to USB via the FT2233HP. This mode is enabled in the external EEPROM.

When configured in this mode, the pins used, and the descriptions of the signals are shown in Table 12.

FT2233HP/FT2232HP								
Channel A Pin No.			Channel B Pin No.			Name	Type	CPU-Style FIFO Interface Configuration Description
QFN-68	QFN-76	LQFP-80	QFN-68	QFN-76	LQFP-80			
6,7,1 1-16	8,9,13- 18	8,9,13- 18	34- 38,40- 42	36-40, 42-44	37- 41,43 -45	Channel A = ADBUS[7:0] Channel B = BDBUS[7:0]	I/O	D7 to D0 bidirectional data bus
17	19	19	45	48	50	CS#	INPUT	Active low chip select input
18	20	21	46	49	51	A0	INPUT	Address bit A0
19	21	22	47	50	52	RD#	INPUT	Active Low FIFO Read input
20	22	23	48	51	53	WR#	INPUT	Active Low FIFO Write input

Table 12 – Channel A & B CPU-Style FIFO Interface Configured Pin Descriptions

3.6.7 FT2233HP/FT2232HP pins used in an MPSSE

The FT2233HP/FT2232HP channel A and channel B, each have a Multi-Protocol Synchronous Serial Engine (MPSSE). Each MPSSE can be independently configured to a number of industry standard serial interface protocols such as JTAG, I²C or SPI, or it can be used to implement a proprietary bus protocol. For example, it is possible to use one of the FT2233HP/FT2232HP's channels (e.g., channel A) to connect to an SRAM configurable FPGA such as supplied by Altera or Xilinx. The FPGA device would normally be un-configured (i.e., have no defined function) at power-up. Application software on the PC could use the MPSSE to download configuration data to the FPGA over USB. This data would define the hardware function on power up. The other MPSSE channel (e.g., channel B) would be available for another serial interface function. Alternatively, each MPSSE can be used to control a number of GPIO pins. When configured in this mode, the pins used, and the descriptions of the signals are shown in Table 13.

FT2233HP/FT2232HP								
Channel A Pin No.			Channel B Pin No.			Name	Type	MPSSE Configuration Description
QFN-68	QFN-76	LQFP-80	QFN-68	QFN-76	LQFP-80			
6	8	8	34	36	37	TCK/SK	OUTPUT	Clock Signal Output. For example: JTAG – TCK, Test interface clock SPI – SK, Serial Clock
7	9	9	35	37	38	TDI/DO	OUTPUT	Serial Data Output. For example: JTAG – TDI, Test Data Input SPI – DO, serial data output
11	13	13	36	38	39	TDO/DI	INPUT	Serial Data Input. For example: JTAG – TDO, Test Data output

								SPI – DI, Serial Data Input
12	14	14	37	39	40	TMS/CS	OUTPUT	Output Signal Select. For example: JTAG – TMS, Test Mode Select SPI – CS, Serial Chip Select
13	15	15	38	40	41	GPIOL0	I/O	General Purpose input/output
14	16	16	40	42	43	GPIOL1	I/O	General Purpose input/output
15	17	17	41	43	44	GPIOL2	I/O	General Purpose input/output
16	18	18	42	44	45	GPIOL3	I/O	General Purpose input/output

Table 13 – Channel A & B MPSSE Configured Pin Descriptions

For a functional description of this mode, please refer to [Section 4.6](#).

3.6.8 FT2233H/FT2232HP Pins Configured as a Host Bus Emulation Interface

The FT2233HP/FT2232HP can be used to combine channel A and channel B to be configured as a host bus emulation interface mode which emulates a standard 8048 or 8051 MCU host.

When configured in this mode, the pins used, and the descriptions of the signals are shown in Table 14.

FT2233HP/FT2232HP					
Pin No.			Name	Type	Host Bus Emulation Interface Configuration Description
QFN-68	QFN-76	LQFP-80			
6,7,11-16	8,9,13-18	8,9,13-18	ADBUS[7:0]	I/O	Multiplexed bidirectional Address/Data bus AD7 to AD0
17-24	19-26	19, 21-27	A[15:8]	OUTPUT	Extended Address A15 to A8
34	36	37	CS#	OUTPUT	Active low chip select device during Read or Write.
35	37	38	ALE	OUTPUT	Positive pulse to latch the address
36	38	39	RD#	OUTPUT	Active low read output.
37	39	40	WR#	OUTPUT	Active low write output. (Data is setup before WR# goes low, and is held after WR# goes high)
38	40	41	IORDY	INPUT	Extends the time taken to perform a Read or Write operation if driven low. Pull up to V _{CORE} if not being used.
40	42	43	CLKOUT	OUTPUT	Master clock. Outputs the clock signal being used by the configured interface.
41	43	44	I/O0	I/O	MPSSE mode instructions to set / clear or read the high byte of data can be used with this pin. Please refer to Application Note AN_108 for operation of these instructions.
42	44	45	I/O1	I/O	MPSSE mode instructions to set / clear or read the high byte of data can be used with this pin. In addition, this pin has instructions which will make the controller wait until it is high, or wait until it is low. This can be used to connect to an IRQ pin of a peripheral chip. The FT2233HP/FT2232HP will wait for the interrupt, and then read the device, and pass the answer back to the host PC. I/O1 must be held in input mode if this option is used. Please refer to Application Note AN_108 for operation of these instructions.

Table 14 – Channel A & B Host Bus Emulation Interface Configured Pin Descriptions

4 Function Description

The FT2233HP/FT2232HP are a USB 2.0 High Speed (480Mb/s) to UART/MPSSE IC with USB Type-C/PD ports. It has the capability of being configured in a variety of industry standard serial interfaces.

The FT2233HP/FT2232HP have two independent configurable interfaces. Both interfaces can be configured as UART, bit-bang mode or JTAG, SPI, I²C mode, using the MPSSE, with independent baud rate generators.

The FT2233HP has two Type-C/PD ports (FT2233HPQ and FT2233HPL only), with PD1 port supporting both power sink and source roles, and PD2 port works as a power sink port. Both PD ports support 5V3A, 9V3A, 12V3A, 15V3A and 20V3A PDO profiles, and these profiles are configurable through the external EEPROM at power-up or reset. PD1 port share the same Type-C connector with USB data, and PD2 port is power port only without USB data.

4.1 Key Features

USB Type-C/PD Controller. The FT2233HP has 2 USB Type-C and PD port controllers (FT2233HPQ and FT2233HPL only), one port is with the legacy USB 2.0 port to form USB PD port, and the other port is standalone PD port it is used to connect to PD power source. Power Delivery function is designed to meet PD2.0/3.0 specification.

USB High Speed to Dual Interface. The FT2233HP/FT2232HP are a USB 2.0 High Speed (480Mbps/s) to dual independent flexible/configurable serial interfaces. This function is backward compatible to FT2232H.

Functional Integration. The FT2233HP/FT2232HP integrate a USB protocol engine which controls the physical Universal Transceiver Macrocell Interface (UTMI) and handles all aspects of the USB 2.0 High Speed interface. The FT2233HP includes an integrated +1.2V Low Drop-Out (LDO) regulator and 12MHz to 480MHz PLL. It also includes 4kbytes Tx and Rx data buffers per channel. The FT2233HP effectively integrates the entire USB protocol on a chip.

MPSSE. Multi-Purpose Synchronous Serial Engines (MPSSE), capable of speeds up to 30 Mbits/s, provides flexible synchronous interface configurations.

Data Transfer Rate. The FT2233HP/FT2232HP support a data transfer rate up to 12 Mbit/s when configured as a UART RS232/RS422/RS485 interface. Please note the FT2233HP/FT2232HP do not support the baud rates of 7 Mbaud 9 Mbaud, 10 Mbaud and 11 Mbaud. Only limited high speed baud rates are possible down to 6Mbaud, below this rate the divider and sub-integer dividers start to have effect offering a wider range of baud rates. In addition, the FT2233HP/FT2232HP support a data transfer rate up to 480 Mbyte/sec in Synchronous FIFO Mode and 8 Mbyte/sec in Asynchronous FIFO Mode.

Latency Timer. This is used to as a timeout to flush short packets of data back to the PC. The default is 16ms, but it can be altered between 2ms and 255ms.. Lower values may reduce latency but may also increase USB bandwidth usage and reduce efficiency.

4.2 Functional Block Descriptions

Type-C/PD PHY and Controller. The FT2233HP has two Type-C/PD ports. Each port has Type-C/PD required Physical Layer (PHY) and controllers. PD1 port has built-in VCONN switches supporting up to 660mW VCONN power (FT2233HPQ and FT2233HPL only).

PD Policy Engine. The PD policy engine is a 32bit RISC processor with 8kB data RAM and 48kB ROM. It manages both PD port 1 and port 2(FT2233HPQ and FT2233HPL only). Default PD configurations are stored in the ROM code. PD1 port can act as power sink or source role, supporting both normal power role swap protocols. PD2 port acts as power sink, which can be connected to a PD charger. By using an external EEPROM, it is possible to change the PD configuration based on specific use cases, such as port 1 sink, port 1 sink/source or PD charge through from port 2 to port 1. PDO voltage/current profiles can also be customised using EEPROM.

I2C Slave Interface. The application can also choose to control the PD policy by external MCU through I2C interface. In this case the built-in PD policy engine is halted. The external MCU has full control to the two PD controller registers (FT2233HPQ and FT2233HPL only) through I2C access. An interrupt signal is also provided, so that an interrupt to an external MCU could be asserted when a PD event occurs.

GPIO block. The GPIO block provides up to 8 GPIO pins which can be used as power switch controls based on the PD policy and profiles.

Dual Multi-Purpose UART/MPSSE Controllers. The FT2233HP/FT2232HP have two independent UART/MPSSE Controllers. These blocks control the UART data or control the Bit-Bang mode if selected by the FT_SetBitMode command. Both can be used independently of each other and the remaining UART channels. Using this, the device can be configured under software command to have 1 MPSSE + 1 UARTS (each UART can be set to Bit Bang mode to gain extra I/O if required).

USB Protocol Engine and FIFO control. The USB Protocol Engine controls and manages the interface between the UTMI PHY and the FIFOs of the chip. It also handles power management and the USB protocol specification.

Dual Port FIFO TX Buffer (4Kbytes per channel). Data from the Host PC is stored in these buffers to be used by the Multi-purpose UART/FIFO controllers. This is controlled by the USB Protocol Engine and FIFO control block.

Dual Port FIFO RX Buffer (4Kbytes per channel). Data from the Multi-purpose UART/FIFO controllers is stored in these blocks to be sent back to the Host PC when requested. This is controlled by the USB Protocol Engine and FIFO control block.

RESET Generator. The integrated Reset Generator Cell provides a reliable power-on reset to the device internal circuitry at power up. The RESET# input pin allows an external device to reset the FT2233HP/FT2232HP. RESET# should be tied to VCCIO (+3.3v) if not being used.

Independent Baud Rate Generators. The Baud Rate Generators provide an x16 or an x10 clock input to the UART's from a 120MHz reference clock and consist of a 14-bit pre-scaler and 4 register bits which provide fine tuning of the baud rate (used to divide by a number plus a fraction). This determines the Baud Rate of the UART which is programmable from 183 baud to 12 million baud. The FT2233HP/FT2232HP do not support the baud rates of 7 Mbaud 9 Mbaud, 10 Mbaud and 11 Mbaud.

See FTDI application note [AN_120](#) for more details.

LDO Regulator. The +1.2V LDO regulator generates the +1.2 volts for the core and the USB transceiver cell. Its input (VREGIN) must be connected to a +3.3V external power source. It is also recommended to add an external filtering capacitor to the VREGIN. There is no direct connection from the +1.2V output (VREGOUT) and the internal functions of the FT2233HP/FT2232HP. The PCB must be routed to connect VREGOUT to VCORE, the pins that require the +1.2V including VREGIN. This output should not be used to power other circuits apart from VCORE.

USB HS PHY. The Universal Transceiver Macrocell Interface (UTMI) physical interface cell. This block handles the Full speed / High Speed SERDES (serialise – de-serialise) function for the USB TX/RX data. It also provides the clocks for the rest of the chip. A 12 MHz crystal should be connected to the OSCI and OSCO pins. A 12K Ohm resistor should be connected between REF and GND on the PCB.

EEPROM Interface. EEPROM is mandatory for configuration of PD Port and the power profiles. Adding an external EEPROM allows customization of USB VID, PID, Serial Number, Product Description Strings and Power Descriptor value of the FT2233HP/FT2232HP for OEM applications, as well as PD port configurations and power profiles. Other parameters controlled by the EEPROM include Remote Wake Up, Soft Pull Down on Power-Off and I/O pin drive strength.

The EEPROM must have a 16-bit wide configuration such as a Microchip 93LC66B or equivalent capable of a 1Mbit/s clock rate at VCC = 3.0V to 3.6V. The EEPROM is programmable in-circuit over USB using a utility program called [FT_PROG](#) available from FTDI's web site – <https://ftdichip.com/>. This allows a blank EEPROM device to be soldered onto the PCB and programmed as part of the manufacturing and test process.

If no EEPROM is connected (or the EEPROM is blank), the FT2233HP/FT2232HP will default to serial ports. The device uses its built-in default VID (0403), PID (6040), Product Description and Power Descriptor Value. In this case, the device will not have a serial number as part of the USB descriptor. As for the power delivery configuration, please refer to [AN_448](#) for FT2233HP and [AN_551](#) for FT2232HP.

4.3 FT232 UART Interface Mode Description

The FT2233HP/FT2232HP can be configured in similar UART modes as the FTDI FT232R/FT-X devices (an asynchronous serial interface). The following examples illustrate how to configure the FT2233HP/FT2232HP with an RS232, RS422 or RS485 interfaces. The FT2233HP/FT2232HP can be configured as a mixture of these interfaces.

4.3.1 RS232 Configuration

Figure 5 illustrates how the FT2233HP/FT2232HP channel A can be configured with an RS232 UART interface. This can be repeated for channels B to provide a dual RS232 but has been omitted for clarity.

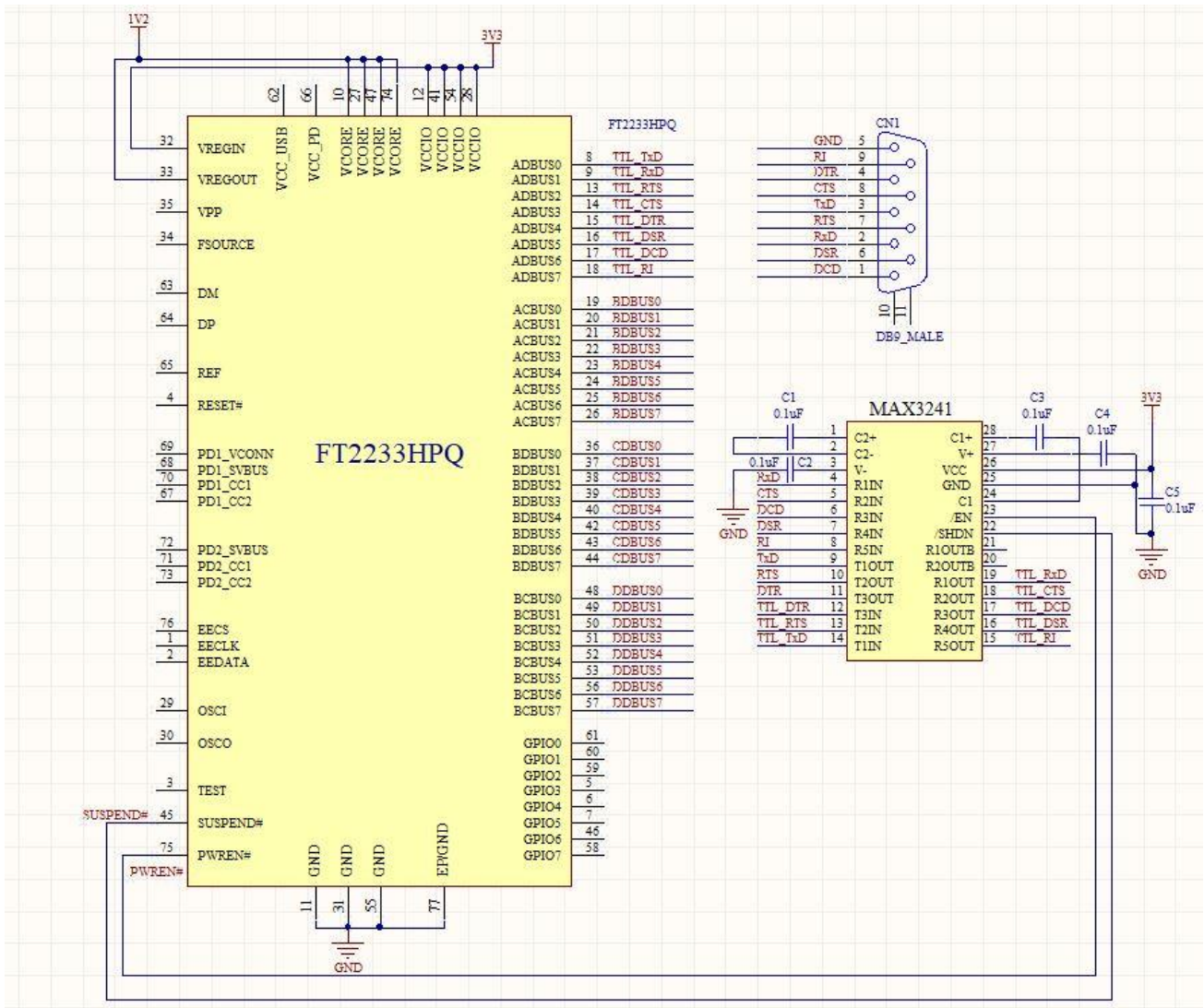

Figure 5 – Single RS232 Configurations

4.3.2 RS422 Configuration

Figure 6 illustrates how the FT2233HP/FT2232HP can be configured as a dual RS422 interface. The FT2233HP/FT2232HP can have all 2 channels connected as RS422.

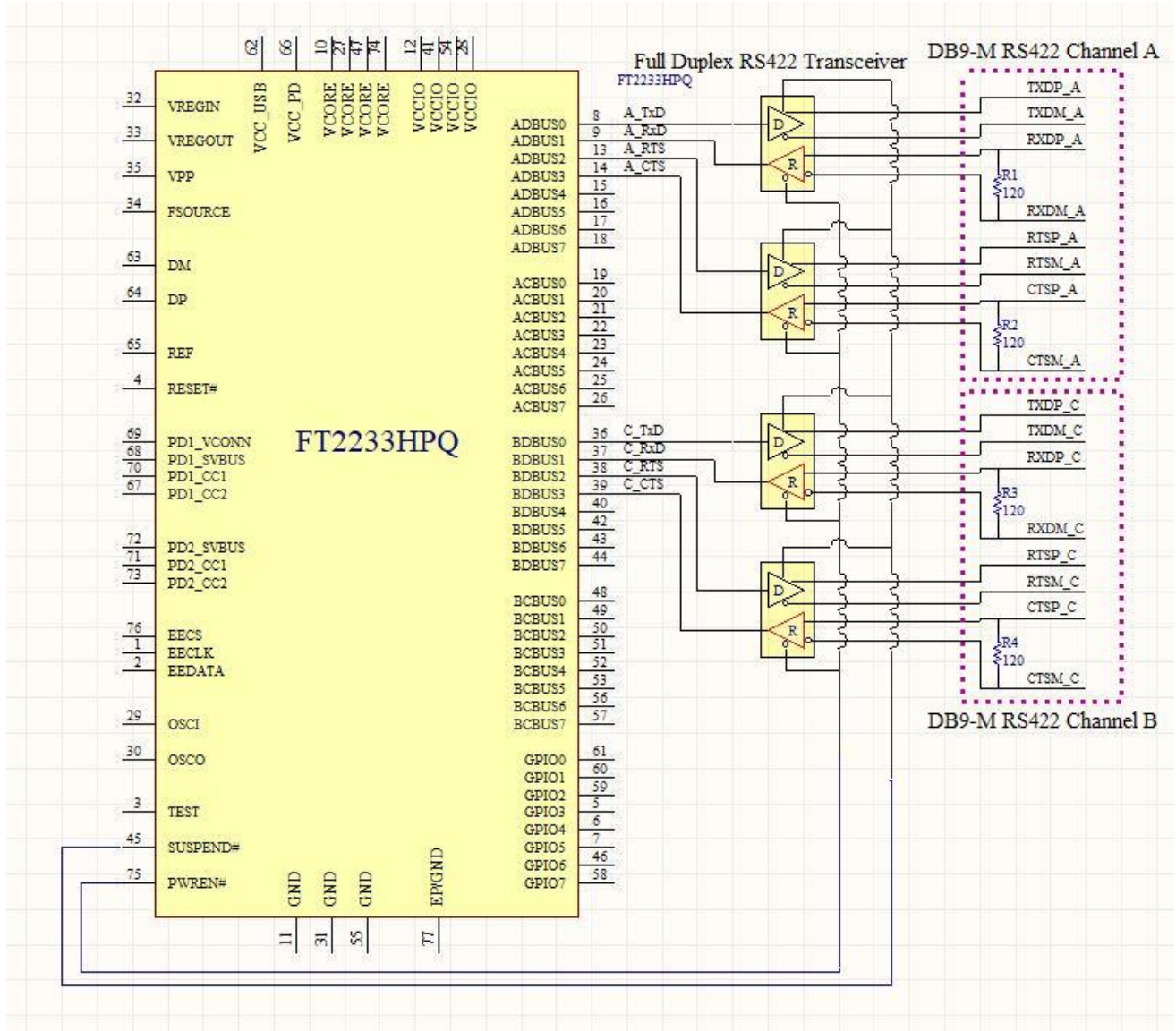

Figure 6 – Dual RS422 Configurations

In this case both channel A and channel B are configured as UART operating at TTL levels and a level converter device (full duplex RS422 transceiver) is used to convert the TTL level signals from the FT2233HP/FT2232HP to RS422 levels. The PWREN# signal is used to power down the level shifters such that they operate in a low quiescent current when the USB interface is in suspend mode.

4.3.3 RS485 Configuration

Figure 7 illustrates how the FT2233HP/FT2232HP can be configured as a dual RS485 interface. The FT2233HP/FT2232HP can have all 2 channels connected as RS485.

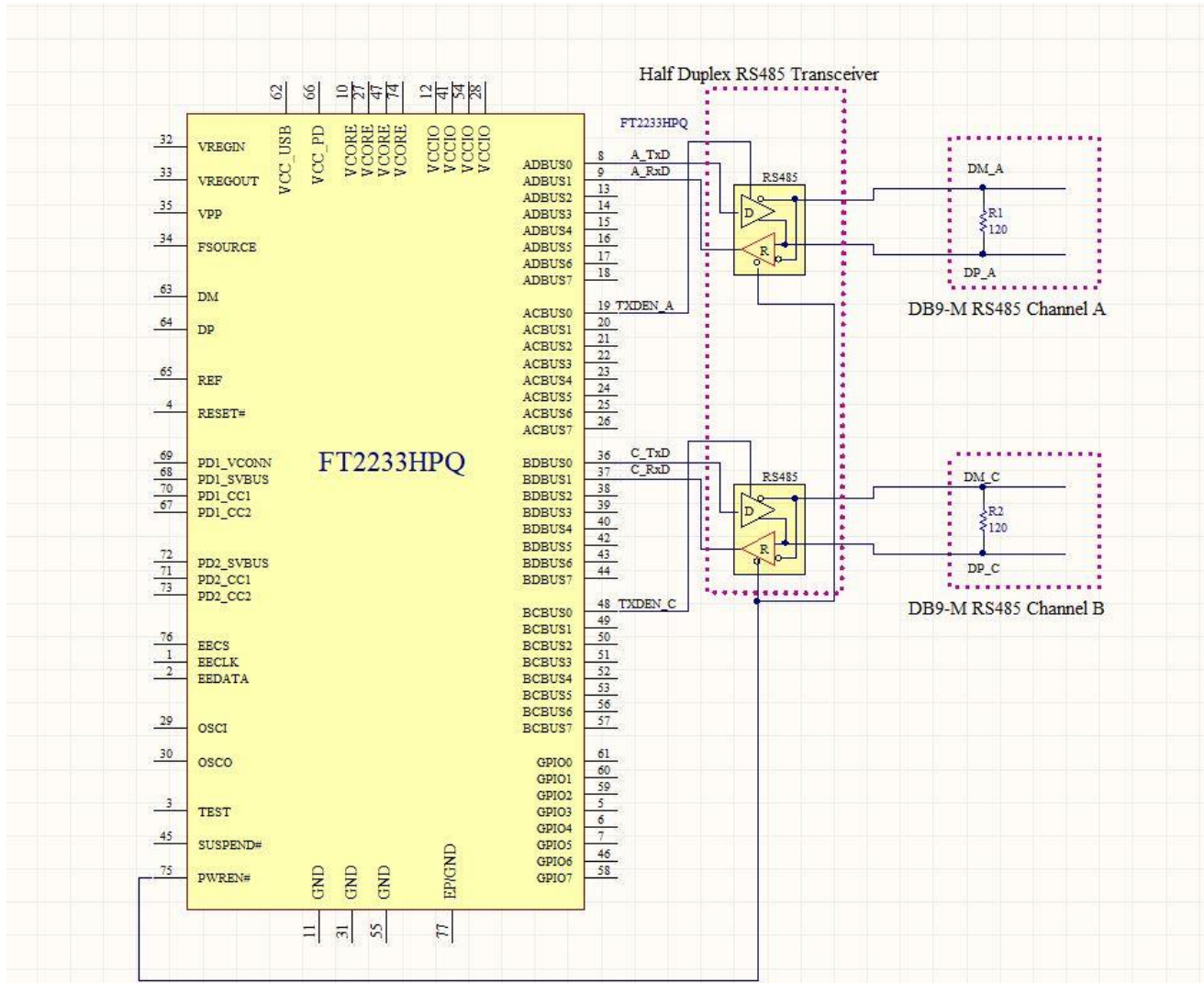

Figure 7 – Dual RS485 Configurations

In this case both channel A and channel B are configured as RS485 operating at TTL levels and a level converter device (half duplex RS485 transceiver) is used to convert the TTL level signals from the FT2233HP/FT2232HP to RS485 levels. It has separate enables on both the transmitter and receiver. With RS485, the transmitter is only enabled when a character is being transmitted from the UART. The TXDEN pins on the FT2233HP/FT2232HP are provided for exactly that purpose, and so the transmitter enables are wired to the TXDEN's. The receiver enable is active low, so it is wired to the PWREN# pin to disable the receiver when in USB suspend mode.

RS485 is a multi-drop network – i.e., many devices can communicate with each other over a single two wire cable connection. The RS485 cable requires to be terminated at each end of the cable. Links are provided to allow the cable to be terminated if the device is physically positioned at either end of the cable.

In this example the data transmitted by the FT2233HP/FT2232HP are also received by the device that is transmitting. This is a common feature of RS485 and requires the application software to remove the transmitted data from the received data stream. With the FT2233HP/FT2232HP it is possible to do this entirely in hardware – simply modify the schematic so that RXD of the FT2233HP/FT2232HP is the logical OR of the level converter device receiver output with TXDEN using an HC32 or similar logic gate.

4.4 FT245 Synchronous FIFO Interface Mode Description

When channel A is configured in an FT245 Synchronous FIFO interface mode the IO timing of the signals used are shown in Figure 8, which shows details for read and write accesses. The timings are shown in Table 15.

Note: that only a read or a write cycle can be performed at any one time. Data is read or written on the rising edge of the CLKOUT clock.

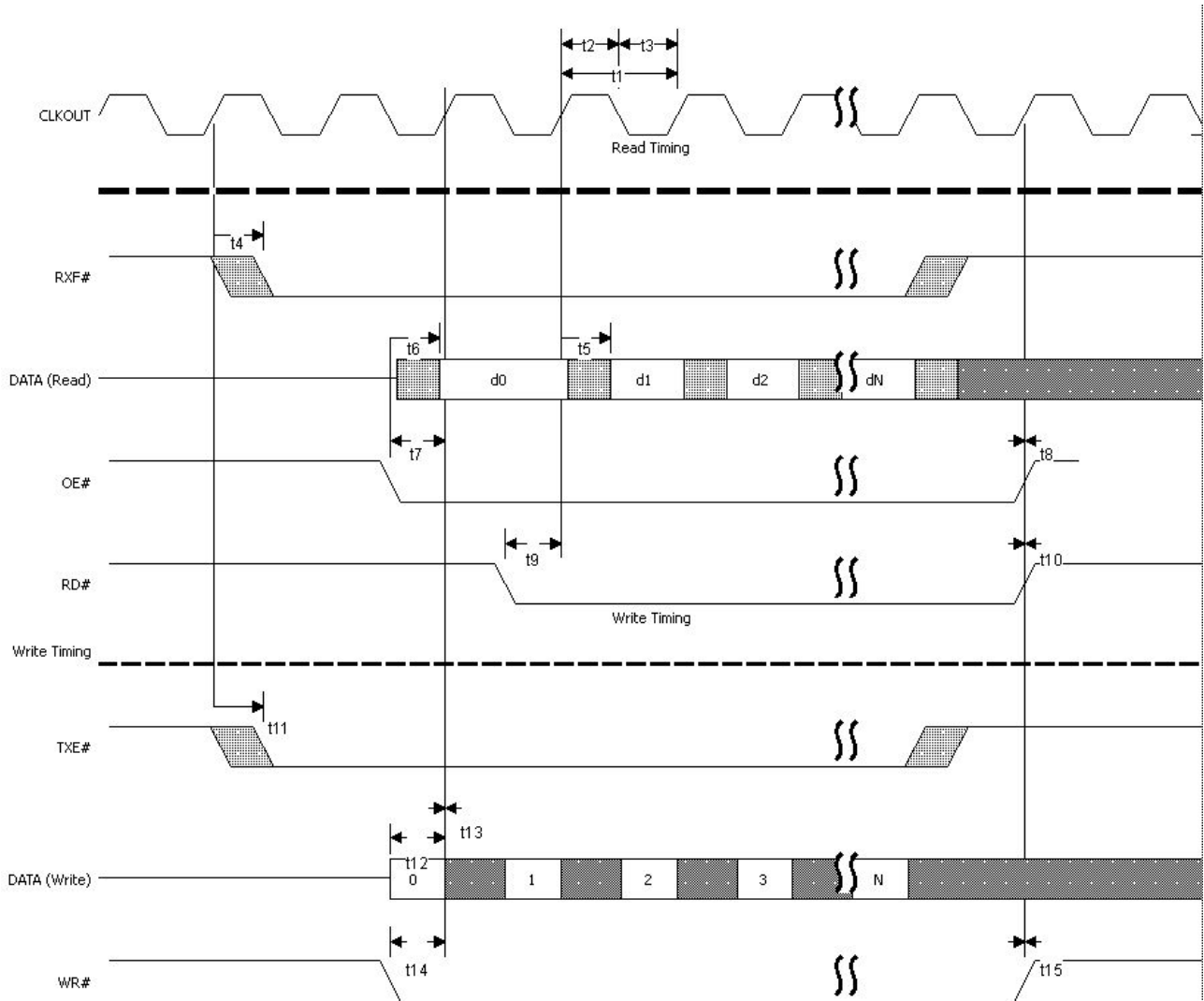

Figure 8 – FT245 Synchronous FIFO Interface Signal Waveforms

Name	Minimum	Typical	Maximum	Units	Description
t1		16.67		ns	CLKOUT period
t2		8.33		ns	CLKOUT high period
t3		8.33		ns	CLKOUT low period
t4	1		7.15	ns	CLKOUT to RXF#
t5	1		11	ns	CLKOUT to read DATA valid
t6	1		10	ns	OE# to read DATA valid
t7	8		16.67	ns	OE# setup time
T8	0			ns	OE# hold time
T9	8		16.67	ns	RD# setup time to CLKOUT (RD# low after OE# low)
T10	0			ns	RD# hold time
t11	1		7.15	ns	CLKOUT TO TXE#

t12	9		16.67	ns	Write DATA setup time
t13	0			ns	Write DATA hold time
t14	9		16.67	ns	WR# setup time to CLKOUT (WR# low after TXE# low)
t15	0			ns	WR# hold time

Table 15 – FT245 Synchronous FIFO Interface Signal Timings

Note: These timing numbers are preliminary and subject to change.

This single channel mode uses a synchronous interface to get high data transfer speeds. The chip drives a 60 MHz CLKOUT clock for the external system to use.

Note that Asynchronous FIFO mode must be selected on both channels before selecting the Synchronous FIFO mode in software.

4.4.1 FT245 Synchronous FIFO Read Operation

A read operation is started when the chip drives RXF# low. The external system can then drive OE# low to turn around the data bus drivers before acknowledging the data with the RD# signal going low. The first data byte is on the bus after OE# is low. The external system can burst the data out of the chip by keeping RD# low or it can insert wait states in the RD# signal. If there is more data to be read it will change on the clock following RD# sampled low. Once all the data has been consumed, the chip will drive RXF# high. Any data that appears on the data bus, after RXF# is high, is invalid and should be ignored.

4.4.2 FT245 Synchronous FIFO Write Operation

A write operation can be started when TXE# is low. WR# is brought low when the data is valid. A burst operation can be done on every clock providing TXE# is still low. The external system must monitor TXE# and its own WR# for each byte of data to check that data has been accepted. Both TXE# and WR# must be low for data to be accepted. Refer to TN_167 for more details about USB to FIFO operation.

4.5 FT245 Asynchronous FIFO Interface Mode Description

The FT2233HP/FT2232HP can be configured as a dual channel asynchronous FIFO interface. This mode is similar to the synchronous FIFO interface with the exception that the data is written to or read from the FIFO on the falling edge of the WR# or RD# signals.

This mode does not provide a CLKOUT signal, and it does not expect an OE# input signal. Figure 9 and Figure 10 illustrates the asynchronous FIFO mode timing.

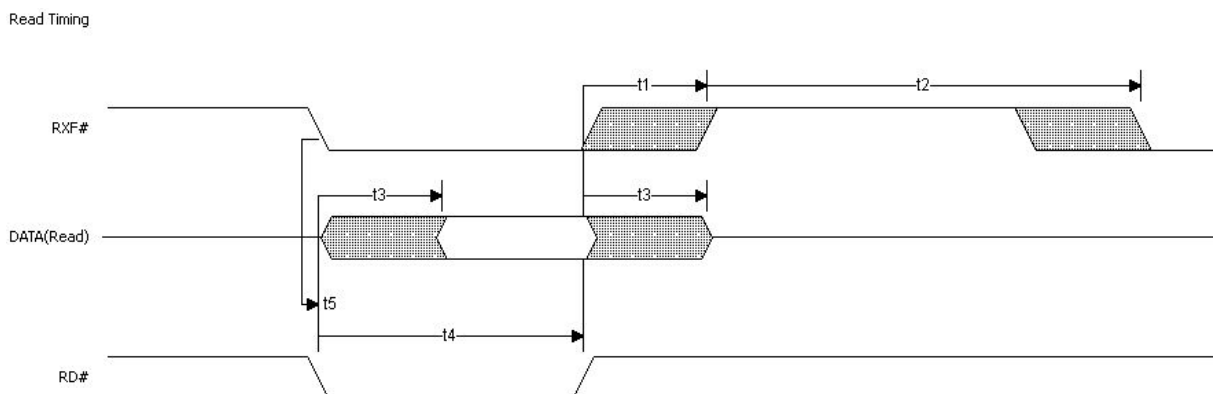

Figure 9 – FT245 Asynchronous FIFO Interface READ Signal Waveforms

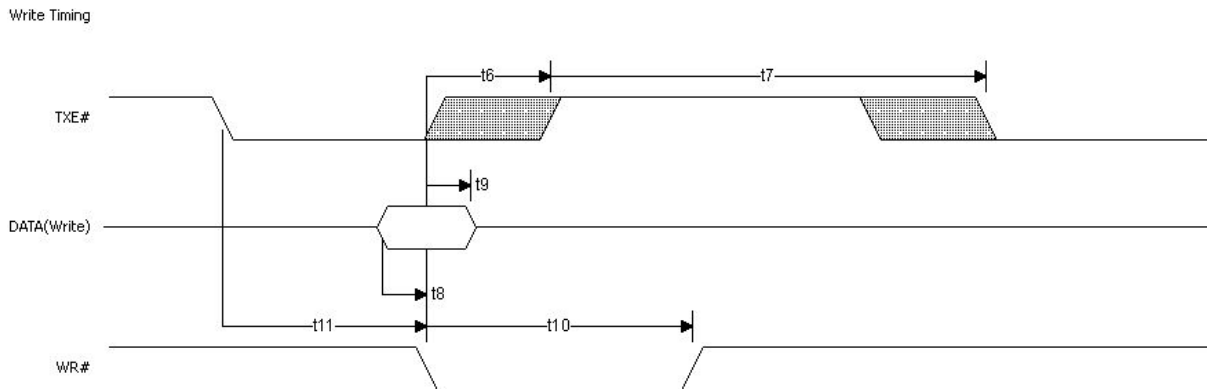

Figure 10 – FT245 Asynchronous FIFO Interface WRITE Signal Waveforms

Name	Minimum	Typical	Maximum	Units	Description
t1	1		14	ns	RD# inactive to RX#
t2	49			ns	RXF# inactive after RD# cycle
t3	1		14	ns	RD# to DATA
t4	30			ns	RD# active pulse width
t5	0			ns	RD# active after RXF#
t6	1		14	ns	WR# active to TXE# inactive
t7	49			ns	TXE# inactive after WR# cycle
t8	5			ns	DATA to WR# active setup time
t9	5			ns	DATA hold time after WR# inactive
t10	30			ns	WR# active pulse width
t11	0			ns	WR# active after TXE#

Table 16 – Asynchronous FIFO Timings (based on standard drive level outputs)

Note: These timing numbers are preliminary and subject to change.

4.6 MPSSE Interface Mode Description

MPSSE Mode is designed to allow the FT2233HP/FT2232HP to interface efficiently with synchronous serial protocols such as JTAG, I2C and SPI Bus. It can also be used to program SRAM based FPGAs over USB. The MPSSE interface is designed to be flexible so that it can be configured to allow any synchronous serial protocol (industry standard or proprietary) to be implemented using the FT2233HP/FT2232HP.

MPSSE is fully configurable and is programmed by sending commands down the data stream. These can be sent individually or more efficiently in packets. MPSSE is capable of a maximum sustained data rate of 30 Mbits/s.

When a channel is configured in MPSSE mode, the IO timing and signals used are shown in Figure 11 – MPSSE Signal Waveforms

and Table 17.

Note: These timing numbers are preliminary and subject to change.

These show timings for CLKOUT=30MHz. CLKOUT can be divided internally to be provide a slower clock.

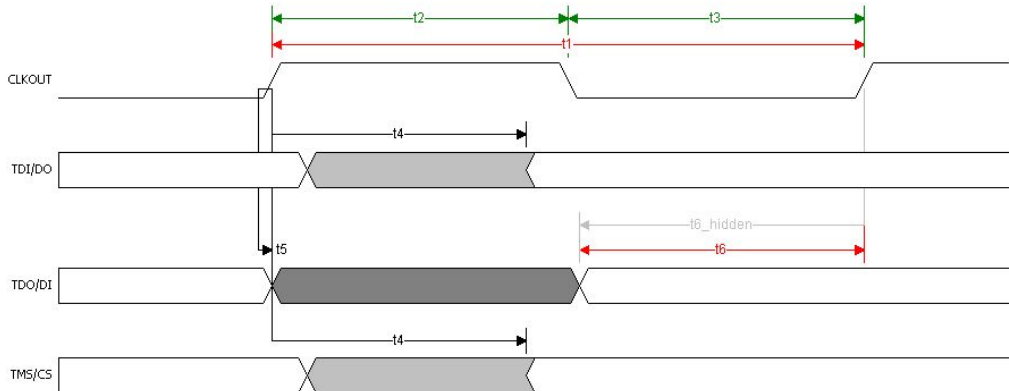

Figure 11 – MPSSE Signal Waveforms

NAME	MIN	NOM	MAX	Units	COMMENT
t1		33.33		ns	CLKOUT period
t2	15	16.67		ns	CLKOUT high period
t3	15	16.67		ns	CLKOUT low period
t4	1		7.15	ns	CLKOUT to TDI/DO delay
t5	0			ns	TDO/DI hold time
t6	11			ns	TDO/DI setup time

Table 17 – MPSSE Signal Timings

Note: These timing numbers are preliminary and subject to change.

MPSSE mode is enabled using FT_SetBitMode driver command. A hex value of 2 will enable it, and a hex value of 0 will reset the device. See application note [AN2232-02, “Bit Mode Functions for the FT2232”](#) for more details and examples.

The MPSSE command set is fully described in application note [AN_108 – “Command Processor for MPSSE and MCU Host Bus Emulation Modes”](#).

The following additional application notes are available for configuring the MPSSE:

- [AN_109 – “Programming Guide for High Speed LibMPSSEI2C DLL”](#)
- [AN_111 – “Programming Guide for High Speed LibMPSSESPI DLL”](#)

4.6.1 MPSSE Adaptive Clocking

Adaptive clocking is a new MPSSE feature added to the FT2233HP/FT2232HP MPSSE engine.

The mode is effectively handshaking the CLK signal with a return clock RTCK. This is a technique used by ARM processors.

The FT2233HP/FT2232HP will assert the CLK line and wait for the RTCK to be returned from the target device to GPIOL3 line before changing the TDO (data out line).

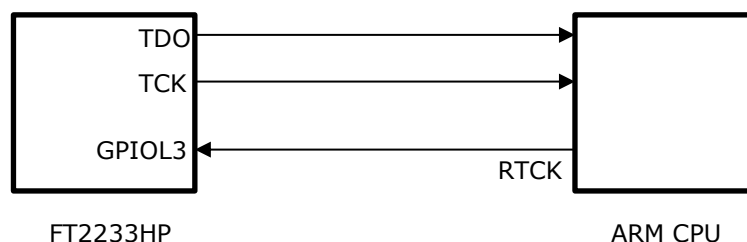

Figure 12 – Adaptive Clocking Interconnect

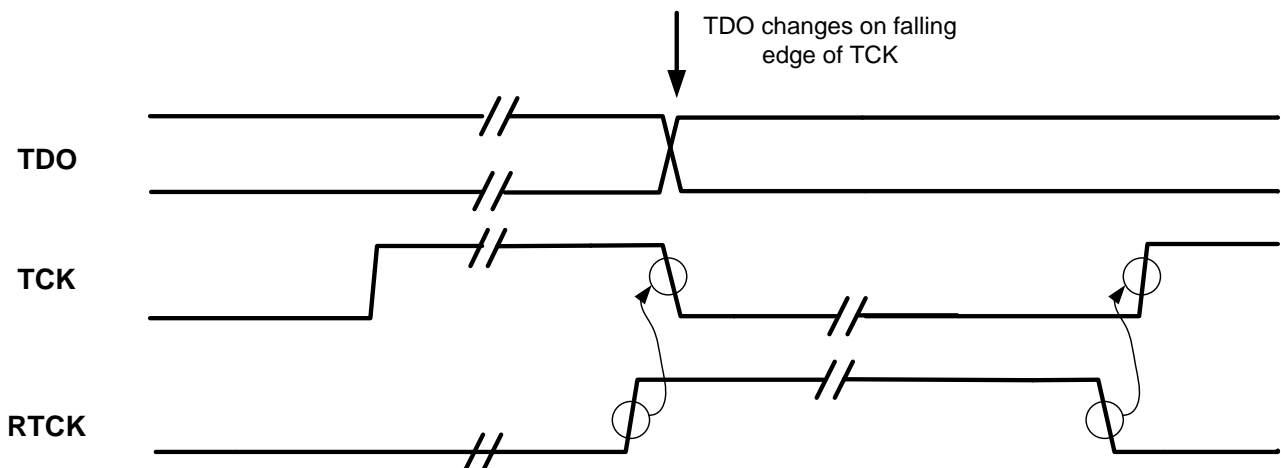

Figure 13 – Adaptive Clocking Waveform

Adaptive clocking is not enabled by default.

See: [AN108 – Command Processor For MPSSE and MCU Host Bus Emulation Modes.](#)

4.7 MCU Host Bus Emulation Mode

MCU host bus emulation mode uses both of the FT2233HP/FT2232HP’s A and B channel interfaces to make the chip emulate a standard 8048/8051 MCU host bus. This allows peripheral devices for these MCU families to be directly connected to USB via the FT2233HP/FT2232HP.

The lower 8 bits (AD7 to AD0) is a multiplexed Address / Data bus. A15 to A8 provide upper (extended) addresses. There are 4 basic operations: -

- 1) Read (does not change A15 to A8)
- 2) Read Extended (changes A15 to A8)
- 3) Write (does not change A15 to A8)
- 4) Write Extended (changes A15 to A8)

MCU Host Bus Emulation mode is enabled using FT_SetBitMode driver command. A hex value of 8 will enable it, and a hex value of 0 will reset the device. The FT2233HP/FT2232HP operates in the same way as the FT2232D. See application note [AN2232-02, “Bit Mode Functions for the FT2232D”](#) for more details and examples.

The MCU Host Bus Emulation Mode command set is fully described in application note [AN_108 – “Command Processor for MPSSE and MCU Host Bus Emulation Modes”](#).

When MCU Host Bus Emulation mode is enabled the IO signal lines on both channels work together and the pins are configured. The following sections give some details of the read and write cycle waveforms and timings. The CLKOUT output clock can operate up to 60MHz.

In Host Bus Emulation mode, the clock divisor has no effect. The clock divisor is used for serial data and is a different part of the MPSSE block. In host bus emulation the 60MHz clock is always output and doesn’t change with any commands.

4.7.1 MCU HOST Bust Emulation Mode Signal Timing – Write Cycle

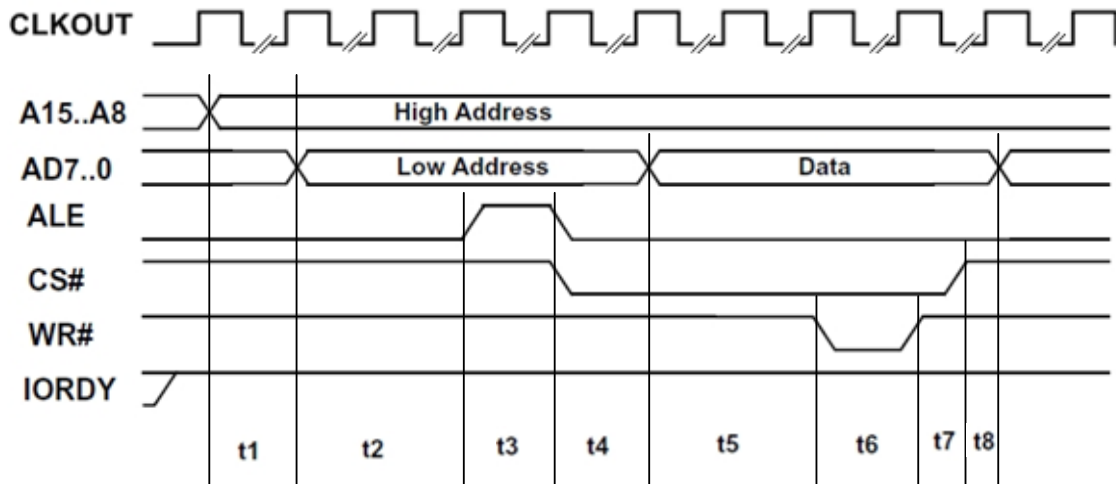

Figure 14 – MCU Host Bus Emulation Mode Signal Waveforms – WRITE Cycle

Div By 5	Number of clock cycles For Write				
	On		Off		
	Low	High	Low	High	
IORDY	Low	High	Low	High	
t1	6	6	2	2	A15-8 to AD7-0
t2	3	3	1	1	AD7-0 to ALE
t3	10	5	2	1	ALE width
t4	2	2	2	2	ALE to Address not Valid
t5	13	3	1	1	AD7-0 Data Valid to WRn
t6	10	5	6	1	WRn width
t7	1	1	1	1	WRn inactive to CSn inactive
t8	1	1	1	1	CSn inactive to AD7-0 not valid

Table 18 – MCU Host Bus Emulation Mode Signal Timings – WRITE Cycle

When Div by 5 is on the device will return 2 bytes (the same value) when doing a read. When it is off the device will return 1 byte when doing a read. The clock period is 16.67 nS so most devices would need the Div by 5 to be set on. IORDY can be held low permanently to extend all cycles.

4.7.2 MCU Host Bus Emulation Mode Signal Timing – Read Cycle

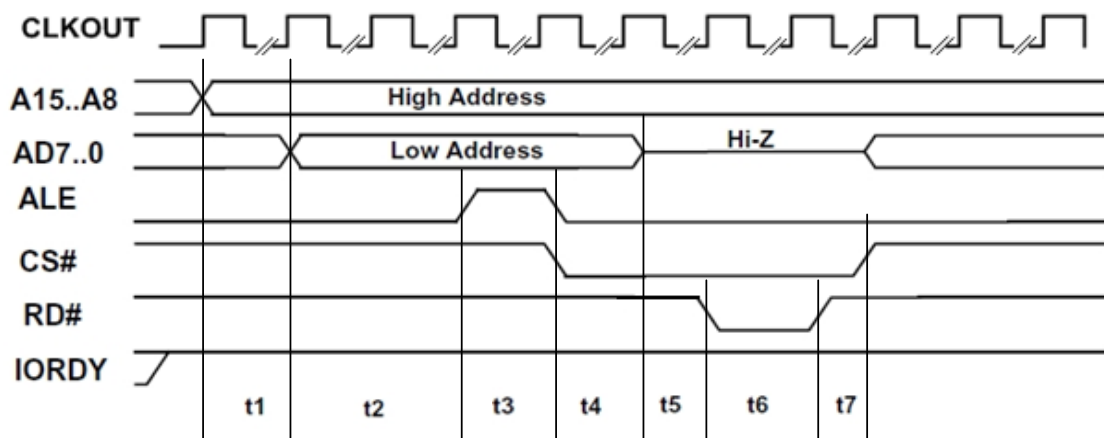

Figure 15 – MCU Host Bus Emulation Mode Signal Waveforms – READ Cycle

Div By 5	Number of clock cycles For Read				
	On		Off		
	Low	High	Low	High	
IORDY					
t1	6	6	2	2	A15-8 to AD7-0
t2	3	3	1	1	AD7-0 to ALE
t3	10	5	2	1	ALE width
t4	2	5	2	1	ALE to Address not Valid
t5	13	0	1	0	Address not Valid to RDn active
t6	10	10	6	2	RDn active
t7	1	1	1	1	RDn inactive to CSn inactive

Table 19 – MCU Host Bus Emulation Mode Signal Timings – READ Cycle

When Div by 5 is on the device will return 2 bytes when doing a read. When it is off the device will return 1 byte when doing a read. The clock period is 16.67 nS so most devices would need the Div by 5 to be set on. IORDY can be held low permanently to extend all cycles.

An example of the MCU Host Emulation Interface enabling a USB interface to CAN Bus using a CANBus Controller is shown in the Figure 16.

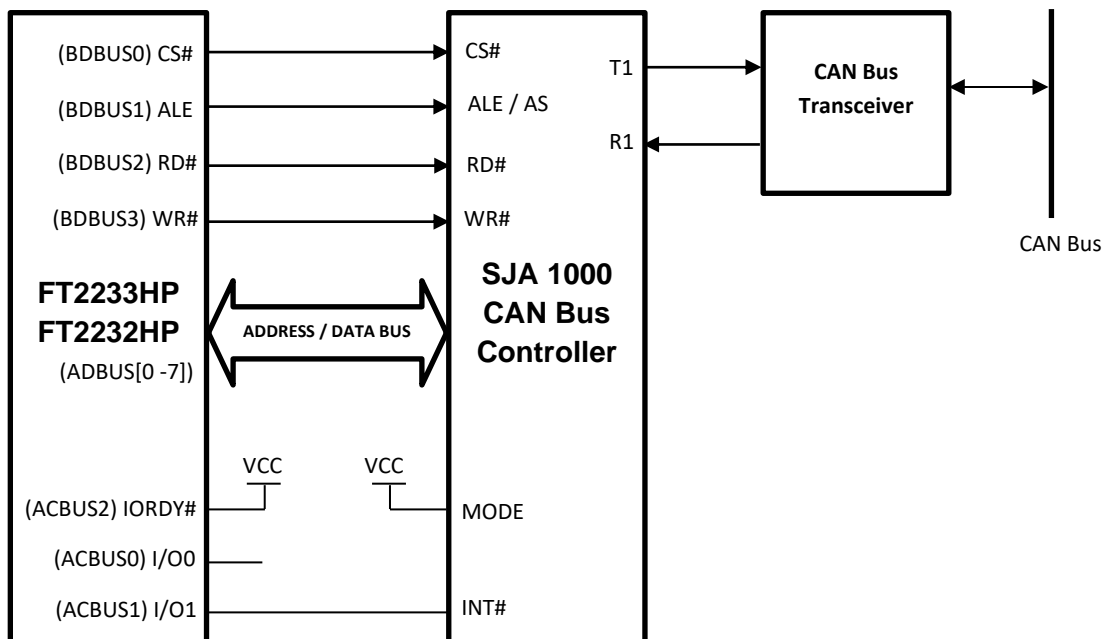

Figure 16 – MCU Host Emulation Example using a CANBus Controller

4.8 Fast Opto-Isolated Serial Interface Mode Description

Fast Opto-Isolated Serial Interface Mode provides a method of communicating with an external device over USB using 4 wires that can have opto-isolators in their path, thus providing galvanic isolation between systems. If either channel A or channel B is enabled in Fast Opto-Isolated Serial mode then the pins on channel B are switched to the fast serial interface configuration. The I/O interface for fast serial mode is always on channel B, even if both channels are being used in this mode. An address bit is used to determine the source or destination channel of the data. It therefore makes sense to always use at least channel B or both for fast serial mode, but not A own its own.

Fast serial mode is enabled by setting the appropriate bits in the external EEPROM. The fast serial mode can be held in reset by setting a bit value of 10 using the Set Bit Bang Mode command. While this bit is set the device is held reset – data can be sent to the device, but it will not be sent out by the device until the device is enabled again. This is done by sending a bit value of 0 using the set bit mode command. See application note [AN2232L-02, “Bit Mode Functions for the FT2232D](#) for more details and examples.

When either Channel B or both Channel A and B are configured in Fast Opto-Isolated Serial Interface mode the IO timing of the signals used are shown in Figure 17. The timings are shown in Table 20.

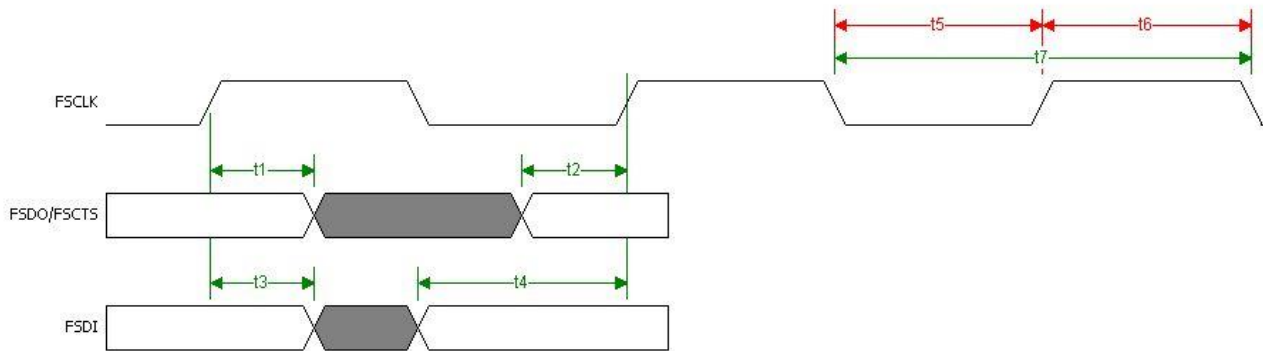

Figure 17 – Fast Opto-Isolated Serial Interface Signal Waveforms

Name	Minimum	Typical	Maximum	Units	Description
t1	1			ns	FSDO/FSCTS hold time
t2	5			ns	FSDO/FSCTS setup time
t3	5			ns	FSDI hold time
t4	10			ns	FSDI Setup Time
t5		8.33		ns	FCLK low
t6		8.33		ns	FCLK high
t7		16.67		ns	FCLK Period

Table 20 – Fast Opto-Isolated Serial Interface Signal Timings

Note: These timing numbers are preliminary and subject to change.

4.8.1 Outgoing Fast Serial Data

To send fast serial data out of the FT2233HP/FT2232HP, the external device must drive the FCLK clock. If the FT2233HP/FT2232HP have data ready to send, it will drive FSDO output low to indicate the start bit. It will not do this if it is currently receiving data from the external device. This is illustrated in Figure 18.

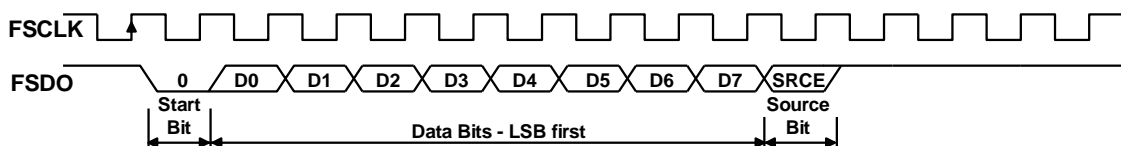

Figure 18 – Fast Opto-Isolated Serial Interface Output Data

Notes:

1. The first bit output (Start bit) is always 0.
2. FSDO is always sent LSB first.
3. The last serial bit output is the source bit (SRCE). It indicates which channel the data has come from. A '0' means that it has come from Channel A, a '1' means that it has come from Channel B.
4. If the target device is unable to accept the data when it detects the START bit, it should stop the FCLK until it can accept the data.

4.8.2 Incoming Fast Serial Data

An external device is allowed to send data into the FT2233HP/FT2232HP if FSCTS is high. On receipt of a zero START bit on FSDI, the FT2233HP/FT2232HP will drop FSCTS on the next positive clock edge. The data from bits 0 to 7 are then clocked in (LSB first). The last bit (DEST) determines where the data will be written to. The data can be sent to either channel A or to channel B. If DEST= '0', the data is sent to channel A, (assuming channel A is enabled for fast serial mode, otherwise the data is sent to channel B). If DEST= '1' the data is sent to channel B, (assuming channel B is enabled for fast serial mode, otherwise the data will go to channel A. (Either channel A, channel B or both channels must be enabled as fast serial mode, or the function is disabled). This is illustrated in Figure 19.

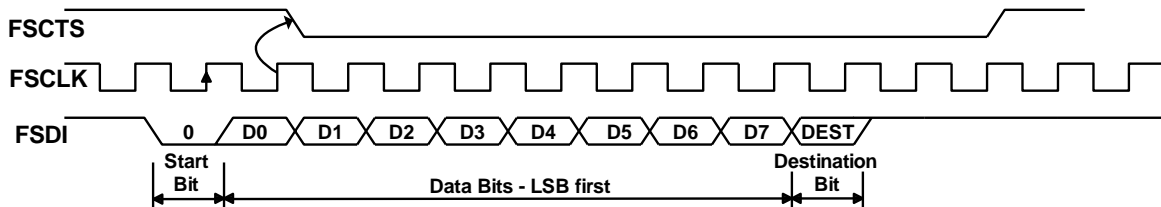

Figure 19 – Fast Opto-Isolated Serial Interface Input Data

Notes:

1. The first bit input (Start bit) is always 0.
2. FSDI is always received LSB first.
3. The last received serial bit is the destination bit (DEST). It indicates which channel the data should go to. A '0' means that it should go to channel A, a '1' means that it should go to channel B.
4. The target device should ensure that CTS is high before it sends data. CTS goes low after data bit 0 (D0) and stays low until the chip can accept more data.

4.8.3 Fast Opto-Isolated Serial Data Interface Example

The following example, (refer to Figure 20) shows two Agilent HCPL-2430 (see the semiconductor section at www.agilent.com) high speed opto-couplers are used to optically isolate an external device which interfaced to USB using the FT2233HP/FT2232HP. In this example VCC5V is the USB VBUS supply and VCCE is the supply to the external device.

Care must be taken with the voltage used to power the photo – LED's. It must be the same voltage as that the FT2233HP/FT2232HP I/Os are driving to, or the LED's may be permanently on. Limiting resistors should be fitted in the lines that drive the diodes. The outputs of the opto-couplers are open-collector and require a pull-up resistor.

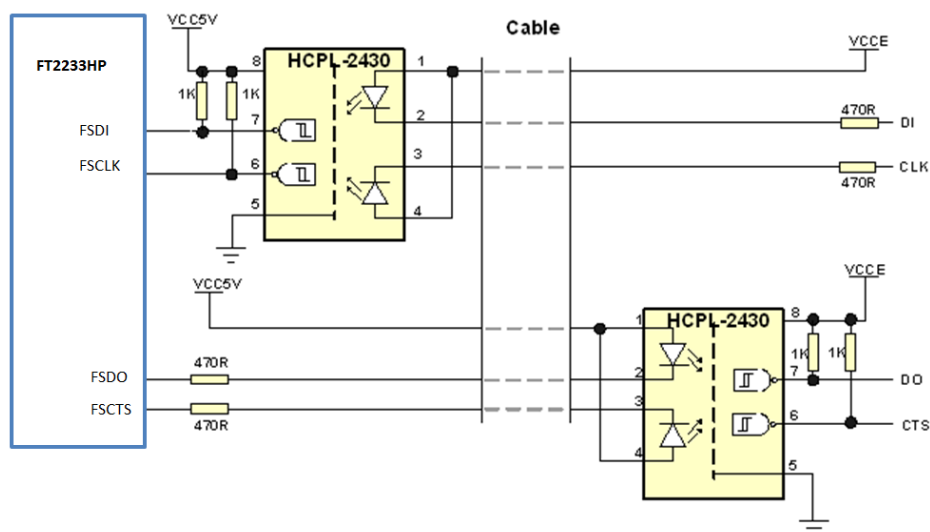

Figure 20 – Fast Opto-Isolated Serial Interface Example

4.9 CPU-Style FIFO Interface Mode Description

CPU-style FIFO interface mode is designed to allow a CPU to interface to USB via the FT2233HP/FT2232HP. This mode is enabled in the external EEPROM. The interface is achieved using a chip select bit (CS#) and address bit (A0). When either Channel A or Channel B are in CPU-style Interface mode the IO signal lines are configured as given in Table 21.

This mode uses a combination of CS# and A0 to determine the operation to be carried out. The following truth-table, Table 22, gives the decode values for particular operations.

CS#	A0	RD#	WR#
1	X	X	X
0	0	Read Data Pipe	Write Data Pipe
0	1	Read Status	Send Immediate

Table 21 – CPU-Style FIFO Interface Operation Select

The Status read is shown in Table 22 –

Data Bit	Data	Status
bit 0	1	Data available (=RXF)
bit 1	1	Space available (=TXE)
bit 2	1	Suspend
bit 3	1	Configured
bit 4	X	X
bit 5	X	X
bit 6	X	X
bit 7	X	X

Table 22 – CPU-Style FIFO Interface Operation Read Status Description

Note that bits 7 to 4 can be arbitrary values and that X= not used.

The timing of reading and writing in this mode is shown in Figure 21 and Table 23.

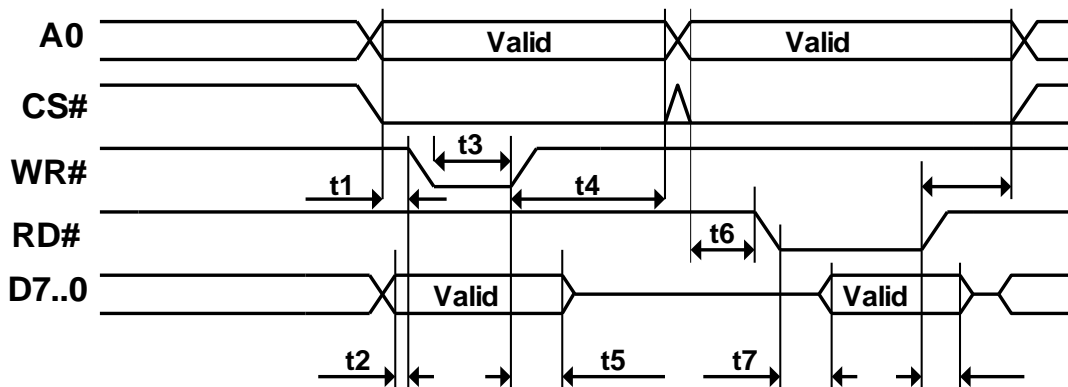

Figure 21 – CPU-Style FIFO Interface Operation Signal Waveforms

Name	Minimum	Typical	Maximum	Units	Description
t1	15			ns	A0 / CS Setup to WR#
t2	15			ns	Data setup to WR#
t3	20			ns	WR# Pulse width
t4	5			ns	A0/CS Hold from WR#
t5	5			ns	Data hold from WR#
t6	15			ns	A0/CS Setup to RD#
t7	15		50	ns	Data delay from RD#
t8	5			ns	A0/CS hold from RD#
t9	0		30	ns	Data hold time from RD#

Table 23 – CPU-Style FIFO Interface Operation Signal Timing

Note: These timing numbers are preliminary and subject to change.

An example of the CPU-style FIFO interface connection is shown in Figure 22.

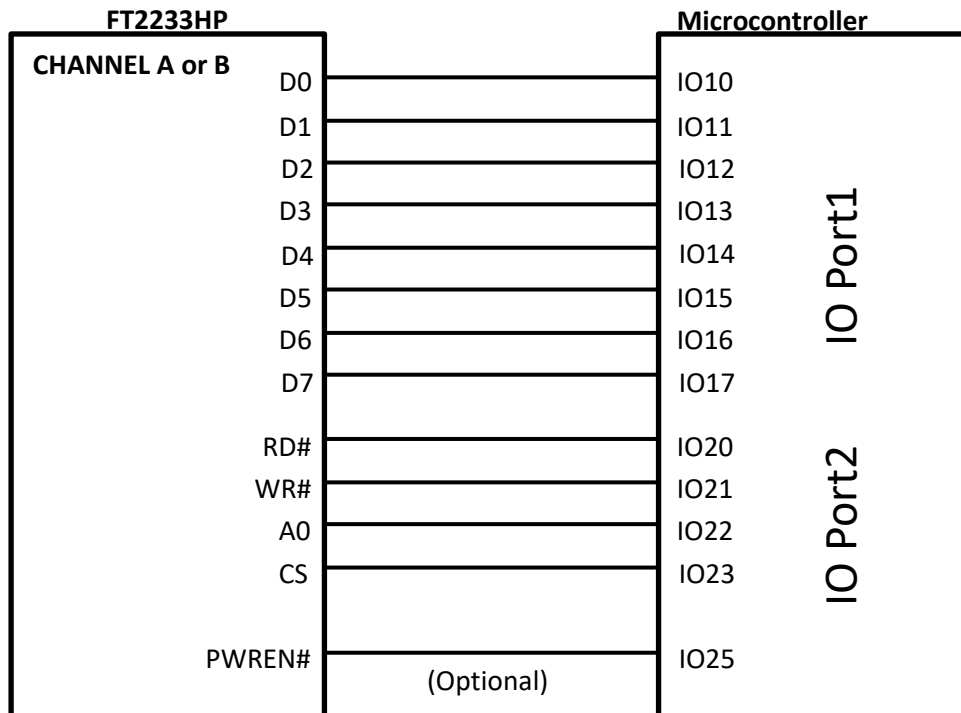

Figure 22 – CPU-Style FIFO Interface Example

4.10 Synchronous and Asynchronous Bit-Bang Interface Mode

The FT2233HP/FT2232HP channel A or channel B can be configured as a bit-bang interface. There are two types of bit-bang modes: synchronous and asynchronous.

4.10.1 Asynchronous Bit-Bang Mode

Asynchronous Bit-Bang mode is the same as BM-style Bit-Bang mode, except that the internal RD# and WR# strobes (RDSTB# and WRSTB#) are now brought out of the device to allow external logic to be clocked by accesses to the bit-bang IO bus.

On either or both channels any data written to the device in the normal manner will be self-clocked onto the data pins (those which have been configured as outputs). Each pin can be independently set as an input or an output. The rate that the data is clocked out at is controlled by the baud rate generator.

For the data to change there has to be new data written, and the baud rate clock has to tick. If no new data is written to the channel, the pins will hold the last value written.

4.10.2 Synchronous Bit-Bang Mode

The synchronous Bit-Bang mode will only update the output parallel port pins whenever data is sent from the USB interface to the parallel interface. When this is done, the WRSTB# will activate to indicate that the data has been read from the USB Rx FIFO buffer and written out on the pins. Data can only be received from the parallel pins (to the USB Tx FIFO interface) when the parallel interface has been written to.

With Synchronous Bit-Bang mode data will only be sent out by the FT2233HP/FT2232HP if there is space in the FT2233HP/FT2232HP USB TXFIFO for data to be read from the parallel interface pins. This Synchronous Bit-Bang mode will read the data bus parallel I/O pins first before it transmits data from the USB RxFIFO. It is therefore 1 byte behind the output, and so to read the inputs for the byte that you have just sent, another byte must be sent.

For example:

(1) Pins start at 0xFF
Send 0x55,0xAA
Pins go to 0x55 and then to 0xAA
Data read = 0xFF,0x55

(2) Pins start at 0xFF
Send 0x55,0xAA,0xAA
(Repeat the last byte sent)
Pins go to 0x55 and then to 0xAA
Data read = 0xFF,0x55,0xAA

Synchronous Bit-Bang Mode differs from Asynchronous Bit-Bang mode in that the device parallel output is only read when the parallel output is written to by the USB interface. This makes it easier for the controlling program to measure the response to a USB output stimulus as the data returned to the USB interface is synchronous to the output data.

Asynchronous Bit-Bang mode is enabled using Set Bit Bang Mode driver command. A hex value of 1 will enable Asynchronous Bit-Bang mode.

Synchronous Bit-Bang mode is enabled using Set Bit Bang Mode driver command. A hex value of 4 will enable Synchronous Bit-Bang mode.

See application note [AN2232-02, "Bit Mode Functions for the FT2232"](#) for more details and examples of using the bit-bang modes.

An example of the synchronous bi-bang mode timing is shown in Figure 23.

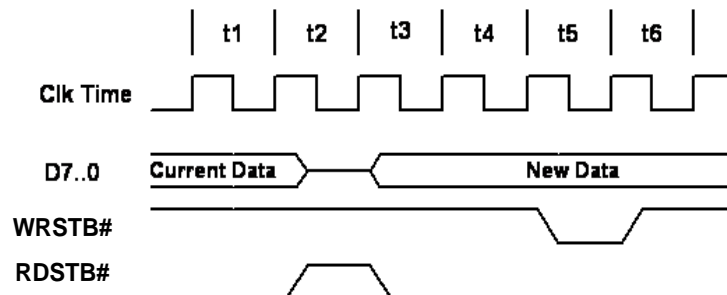

Figure 23 – Synchronous Bit-Bang Mode Timing Interface Example

Name	Description
t1	Current pin state is read
t2	RDSTB# is set inactive and data on the parallel I/O pins is read and sent to the USB host.
t3	RDSTB# is set active again, and any pins that are output will change to their new data
t4	1 clock cycle to allow for data setup
t5	WRSTB# goes active. This indicates that the host PC has written new data to the I/O parallel data pins
t6	WRSTB# goes inactive

Table 24 – Synchronous Bit-Bang Mode Timing Interface Example Timings

WRSTB# = this output indicates when new data has been written to the I/O pins from the Host PC (via the USB interface).

RDSTB# = this output rising edge indicates when data has been read from the I/O pins and sent to the Host PC (via the USB interface).

The WRSTB# goes active in t4. The WRSTB# goes active when data is read from the USB RXFIFO (i.e., sent from the PC). The RDSTB# goes inactive when data is sampled from the pins and written to the USB TXFIFO (i.e., sent to the PC). The FT_SetBitMode command to the FT2233HP/FT2232HP are used to setup the bit-mode. This command also contains a byte wide data mask to set the direction of each bit. The direction on each pin doesn't change unless a new FT_SetBitMode command is used to modify the direction.

The WRSTB# and RDSTB# strobes are only a guide to what may be happening depending on the direction of the bus. For example, if all pins are configured as inputs, it is still necessary to write to these pins in order to get the FT2233HP/FT2232HP to read those pins even though the data written will never appear on the pins.

Signals and data-flow are illustrated in Figure 24.

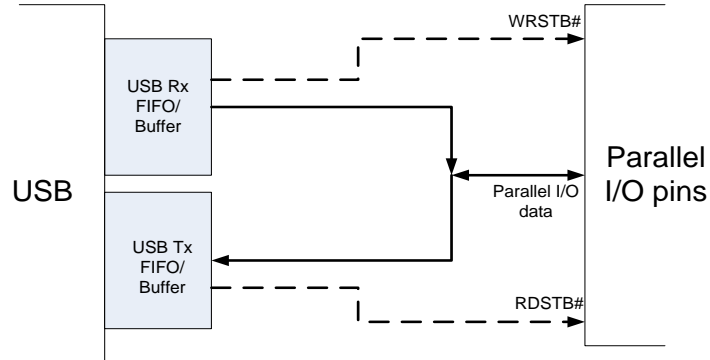

Figure 24 – Bit-Bang Mode Dataflow Illustration Diagram

4.11 RS232 UART Mode LED Interface Description

When configured in UART mode the FT2233HP/FT2232HP has two IO pins on each channel dedicated to controlling LED status indicators, one for transmitted data the other for received data. When data is being transmitted / received the respective pins drive from tri-state to low in order to provide indication on the LEDs of data transfer. A digital one-shot timer is used so that even a small percentage of data transfer is visible to the end user.

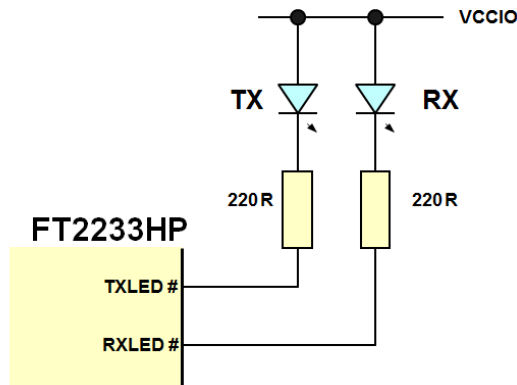

Figure 25 – Dual LED UART Configuration

Figure 25 shows a configuration using two individual LED's – one for transmitted data the other for received data.

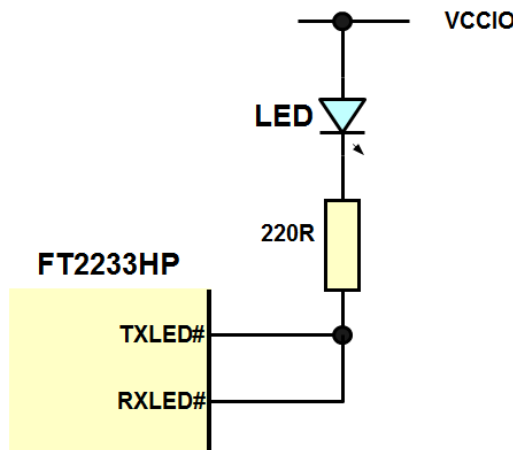

Figure 26 – Single LED UART Configuration

Figure 26 illustrates how to transmit and receive LED indicators are wired together to give a single LED indicator which indicates any transmit or receive data activity.

Note that the LED's are connected to the same supply as VCCIO.

4.12 Send Immediate / Wake Up (SIWU#)

The SIWU# function is available in the FIFO modes and in bit-bang mode.

The Send Immediate portion is used to flush data from the chip back to the PC. This can be used to get short packets of data back to the PC without waiting for the latency timer to expire.

This mechanism should only be used when you have stopped sending data to the chip to avoid overrun.

The data transfer is flagged to the USB host by the falling edge of the signal.

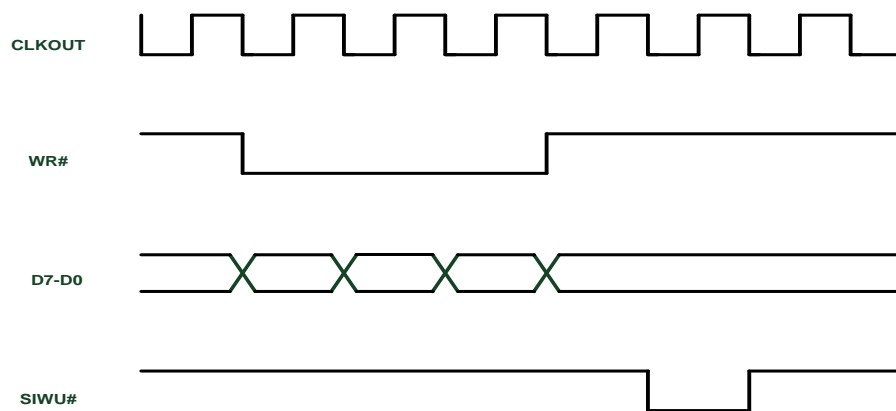

Figure 27 – Using SIWU#

When the pin is being used for a Wake-Up function to wake up a sleeping PC a 20ms negative pulse on this pin is required. When the pin is being used to flush the buffer (Send Immediate), a 250ns negative pulse on this pin is required.

Notes

1. When using remote wake-up, ensure the resistors are pulled-up in suspend. Also ensure peripheral designs do not allow any current sink paths that may partially power the peripheral.
2. A peripheral is allowed to draw up to 2.5mA in suspend.
3. If a Pull-down is enabled, the FT2233HP/FT2232HP will not wake up from suspend.

4.13 FT2233HP/FT2232HP Mode Selection

The two channels of the FT2233H/FT2232HP reset to two asynchronous serial interfaces.

Following a reset, the required mode of each channel is determined by the contents of the EEPROM (programmed using [FT_PROG](#)).

The EEPROM contents determine if the two channels have been configured as FT232 asynchronous serial interface, FT245 FIFO interface, CPU-style FIFO interface or Fast Serial Interface.

Following a reset, the EEPROM is read and the FT2233HP/FT2232HP configured for the selected mode. After device enumeration, the **FT_SetBitMode** command (refer to [D2XX Programmers Guide](#)) can be sent to the USB driver to switch the selected interface into other modes – asynchronous bit-bang, synchronous bit-bang or MPSSE – if required.

When in FT245 FIFO mode, the **FT_SetBitMode** command can be used to select either Synchronous FIFO (**FT_SetBitMode** = 0x40) or Asynchronous FIFO mode. (Note that Asynchronous FIFO mode must be selected on both channels before selecting the Synchronous FIFO mode. This means that an EEPROM is needed to initially configure Asynchronous FIFO mode before software configures the Synchronous FIFO mode).

When Synchronous FIFO mode selected, channel A uses all the memory resources of channel B. As such channel B is then not available. In this case the state of the channel B pins is determined when the configuration is switched to Asynchronous FIFO mode. If channel B had not been used for any data transfer before configuration of Asynchronous FIFO mode, then the channel B pins will remain in their default mode (D7:0=tri-stated but pulled high through 75K resistor, TXE# =low, RXF# =high. RD# and WR# are inputs and should be pulled high). An MPSSE command, **set_data_bits** can be used to configure the channel B pins as inputs before configuring channel A as Synchronous FIFO. This avoids the channel B pins driving against any interfaces (such as SPI) which may have been configured previous to any switching of channel A to Synchronous FIFO mode. Refer to [AN108 Command Processor for MPSSE and MCU Host Bus Emulation Modes](#) for the **set_data_bits** command and further information on the MPSSE used in MCU Host BUS Emulation mode.

The MPSSE can be configured directly using the D2XX commands. Refer to the [D2XX Programmers Guide](#). FTDI have a range of application and software examples for MPSSE. Refer to the Application Notes for further explanation and examples at <https://ftdichip.com/document/application-notes/>.

4.13.1 Do I need an EEPROM?

Table 25 summarises what modes are configurable using the EEPROM or the application software. For Power Delivery related configurable options please refer to Section 8.2.

	ASYN Serial UART	ASYN 245 FIFO	SYNC 245 FIFO	ASYN C Bit- bang	SYNC Bit- bang	MPSSE	Fast Serial interface	CPU- Style FIFO	Host Bus Emulation
<i>EEPROM configured</i>	YES	YES	YES				YES	YES	
<i>Application Software configured</i>			YES	YES	YES	YES			YES

Table 25 – Configuration Using EEPROM and Application Software

4.14 USB Type-C/PD Controller

4.14.1 PD controller description

The FT2233HP has a Type-C/PD controller that fully supports the latest USB Type-C and Power Delivery (PD) 3.0 standards enabling support for power negotiation with the ability to sink or source current to a USB host device. There are two PD ports in the device (FT2233HPQ and FT2233HPL only), one port supports legacy USB 2.0 data transfer as well as providing power sink or source capability, and the other port is standalone PD port as a sink which is used to connect to PD power source. Power Delivery function is designed to meet PD2.0/3.0 specification. If the device is configured to be operated in legacy USB2.0 mode it will be backward compatible to FT2232H in terms of USB2.0 and its peripheral Ios functions.

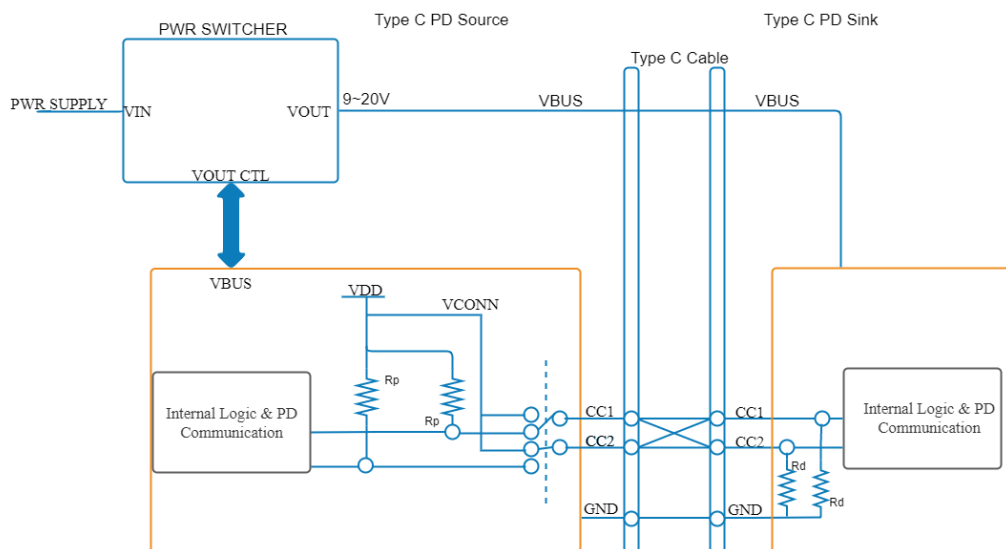

Figure 28 – General PD Working Diagram

4.14.2 Features

- PD 3.0 Compliant.
- Physical layer and Policy Engine.
- Initial Sink, with Dual Role Power (Power Role Swap).
- Multiple Configurable Power Profiles.
- Supports up to 20V3 A power profile.
- Charge through Support.
- Cable Attach and Orientation Detection.
- Supports 1.5A and 3A cables in Type-C legacy mode (NON-PD Mode).
- Profile Selection indication through GPIOs when operating In Sink Mode.
- Supports External MCU to take over the control.
- 8 bit register interface for a low speed processor, or optional I2C port
- Integrated Chapter 6 protocol reduces required MPU response time to 10mS.
- K code recognition/coding, preamble, CRC, etc offloaded from processor.
- VCONN 200mA protected driver switches
- Single 12MHz clock + 32KHz low power clock.
- Slew rate limited driving of CC cable lines drive to 1.1V and 300nS linear transition time.

4.14.3 AC timing on GPIO pins

Best case transition time with 5pF load		Worst case transition time with 15pF load	
Rise(ns)	Fall(ns)	Rise(ns)	Fall(ns)
1.2	1.1	6.0	6.5

Table 26 – AC Timing on GPIO

4.14.4 GPIO Timing for PD Operation

GPIOs are used as a power profile indicator as well as power supply controllers.

When operating as a Sink, GPIO pins are used for LOAD_EN and ISET.

Depending on the kind of profile negotiated, the appropriate ISET GPIO will go high followed by LOAD_EN pin.

The timing between this ISET going high to LOAD_EN can be as high as 12.5uS.

When operating as a Source, GPIO pins are used as power supply controller.

During Source operation, initial voltage will be 5V and then depending on the profile setting, the PD controller can negotiate a higher voltage. The switching from 5V to higher Voltage or vice versa is by switching GPIOs. 5V could be controlled by one Pin whereas each higher Voltage is controlled by a different pin.

For example, Table 27 shows a sample GPIO states for 3 different voltage cases.

	5v	9V	20V
PS_EN	HIGH	HIGH	HIGH
GPIO_9v	LOW	HIGH	LOW
GPIO_20v	LOW	LOW	HIGH

Table 27 – Example GPIO States for Power Control

In this case 5V to 9V or 5v to 20V is just an additional GPIO pin going high. In this case the timing does not matter.

However, in the scenario when the profile changes from 9V to 20V, there is one GPIO going Low whereas another one going high. In this case the delay between one pin going low to another pin going high can be as high as 12.5uS.

4.14.5 Voltage parameters

Based on USB Type-C specification, during initialization when Source connects to Sink, both are in the unattached state. Source firstly detects the Sink's pull down on CC then enters attached state, Source turns on VBUS and VCONN. USB Type-C specification requests voltage parameters shown below:

	Minimum Voltage	Maximum Voltage	Threshold
Powered cable/ Adapter(vRa)	0.00V	0.15V	0.20V
Sink(vRd)	0.25V	1.50V	1.60V
No connect (vOPEN)	1.65V		

Table 28 – CC Voltages on Source Side – Default USB

	Minimum Voltage	Maximum Voltage	Threshold
Powered cable/ Adapter(vRa)	0.00V	0.35V	0.40V
Sink(vRd)	0.45V	1.50V	1.60V
No connect (vOPEN)	1.65V		

Table 29 – CC Voltages on Source Side – 1.5A @ 5V

	Minimum Voltage	Maximum Voltage	Threshold
Powered cable/ Adapter(vRa)	0.00V	0.75V	0.80V
Sink(vRd)	0.85V	2.45V	2.60V
No connect (vOPEN)	2.75V		

Table 30 – CC Voltages on Source Side – 3A @ 5V

To better achieve USB Type-C specification requests, we suggest to use a Schottky Diode to isolate DCDC power from Vcc_PD and PD1_Vconn of FT2233HP/FT2232HP in order to guarantee the expected voltage parameters. The capacitance between Vcc_PD/PD1_Vconn and ground should not be more than 1uF to avoid the slow rise up of CC line due to the leakage through Vcc_PD and PD1_Vconn to the capacitor. The equivalent circuit is shown below:

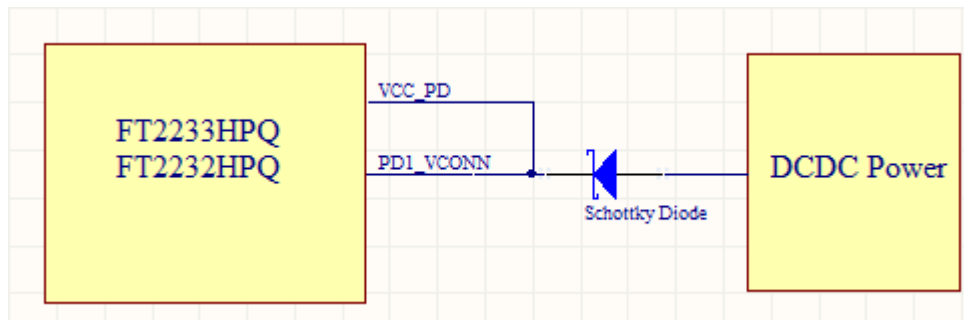

Figure 29 – Schottky Diode Equivalent Circuit

Recommended Schottky diode parameters:

V _I	I _F	V _F
-30V(max)	≤ 5A	≤ 0.3V

Table 31 – Schottky Diode Recommended Characteristics

5 Devices Characteristics and Ratings

5.1 Absolute Maximum Ratings

The absolute maximum ratings for the FT2233HP devices are as follows. These are in accordance with the Absolute Maximum Rating System (IEC 60134). Exceeding these values may cause permanent damage to the device.

Parameter	Value	Unit
Storage Temperature	-65°C to 150°C	Degrees C
Floor Life (Out of Bag) At Factory Ambient (30°C / 60% Relative Humidity)	168 Hours (IPC/JEDEC J-STD-033A MSL Level 3 Compliant) *	Hours
Ambient Operating Temperature (Power Applied)	-40°C to 85°C	Degrees C
MTTF FT2233HPQ	2674098	hours
VCORE Supply Voltage	-0.3 to +2.0	V
VCCIO IO Voltage	-0.3 to +4.0	V
DC Input Voltage – USBDP and USBDM	-0.5 to +3.63	V
DC Input Voltage – High Impedance Bi-directional (powered from VCCIO)	-0.3 to +5.8	V
DC Input Voltage – PD1_CC1, PD1_VCONN, PD1_SVBUS, PD1_CC2, PD2_CC1, PD2_SVBUS, PD2_CC2	-0.5 to (VCC_PD + 0.5)	V
DC Input Volta-e - VPP	-0.5 to 1.85	V
DC Input Volta-e - FSOURCE	-0.5 to 3.7	V
DC Output Current – Outputs	16	mA

Table 32 – Absolute Maximum Ratings

* If devices are stored out of the packaging beyond this time limit the devices should be baked before use. The devices should be ramped up to a temperature of +125°C and baked for up to 17 hours.

5.2 DC Characteristics

DC Characteristics (Ambient Temperature = -40°C to +85°C)

Parameter	Description	Minimum	Typical	Maximum	Units	Conditions
VCORE	VCC Core Operating Supply Voltage	1.08	1.20	1.32	V	
VCCIO*	VCCIO Operating Supply Voltage	2.97	3.30	3.63	V	Cells are 5V tolerant
VREGIN	VREGIN Voltage regulator Input	3.00	3.30	3.60	V	
VREGOUT	Voltage regulator Output	1.08	1.2	1.32	V	
Ireg	Regulator Current		20.26	150	mA	VREGIN +3.3V and data transfer with 12Mbps
Icc1s	VREGIN Suspend Supply Current		1.64		mA	USB Suspend
I_vccio	VCC_IO operating supply current		0.83		mA	UART Data transfer at 12Mbps
I_vcc_pd	VCC_PD suspend supply current		210		uA	PD suspend

Table 33 – Operating Voltage and Current

Note: Failure to connect all VCCIO pins will result in failure of the device.

The I/O pins are +3.3v cells, which are +5V tolerant (except the USB PHY pins).

Parameter	Description	Minimum	Typical	Maximum	Units	Conditions
Voh	Output Voltage High	2.4	3.26	VCCIO	V	Ioh = +/-2mA I/O Drive strength* = 4mA
		2.4	3.28	VCCIO	V	I/O Drive strength* = 8mA
		2.4	3.285	VCCIO	V	I/O Drive strength* = 12mA
		2.4	3.29	VCCIO	V	I/O Drive strength* = 16mA
Vol	Output Voltage Low		0.1	0.4	V	Iol = +/-2mA I/O Drive strength* = 4mA
			0.05		V	I/O Drive strength* = 8mA
			0.04		V	I/O Drive strength* = 12mA
			0.03		V	I/O Drive strength* = 16mA
Vil	Input low Switching Threshold		-	0.80	V	LVTTTL
Vih	Input High Switching Threshold	2.0	-		V	LVTTTL
Vt	Switching Threshold		1.50		V	LVTTTL
Vt-	Schmitt trigger negative going threshold voltage	0.80	1.10	-	V	
Vt+	Schmitt trigger positive going threshold voltage		1.60	2.0	V	
Rpu	Input pull-up resistance**	40	75	190	KΩ	Vin = 0
Rpd	Input pull-down resistance	40	75	190	KΩ	Vin = VCCIO
Iin	Input Leakage Current	-10	+/-1	10	μA	Vin = 0
Ioz	Tri-state output leakage current	-10	+/-1	10	μA	Vin = 5.5V or 0

Table 34 – I/O Pin Characteristics (except USB PHY pins)

*The I/O drive strength and slow slew-rate are configurable in the EEPROM.

**The voltage pulled up to is VCCIO-0.9V in the worst case.

DC Characteristics (Ambient Temperature = -40°C to +85°C)

Parameter	Description	Minimum	Typical	Maximum	Units	Conditions
VCC_USB	PHY Operating Supply Voltage	3.0	3.3	3.6	V	3.3V I/O
I_vcc_usb	PHY Operating Supply Current	---	22.96	--	mA	UART Data transfer at 12Mbps
I_vcc_usb (susp)	PHY Suspend Supply Current	---	0.2	---	mA	USB Suspend

Table 35 – PHY Operating Voltage and Current

Parameter	Description	Minimum	Typical	Maximum	Units	Conditions
USB2.0 Transceiver (HS)						
VHSOI	High-speed idle level output voltage (Differential)	-10		10	mV	
VHSOL	High-speed low level output voltage (Differential)	-10		10	mV	

VHSOH	High-speed high level output voltage (Differential)	-360		400	mV	
VCHIRPJ	Chirp-J output voltage (Differential)	700		1100	mV	
VCHIRPK	Chirp-K output voltage (Differential)	-900		-500	mV	
USB 1.1 Transceiver (FS)						
Voh	Output Voltage High	2.8	-	3.6	V	
Vol	Output Voltage Low	0	-	0.3	V	
Vil	Input low Switching Threshold		-	0.8	V	
Vih	Input High Switching Threshold	2.0	-		V	

Table 36 – PHY I/O Pin Characteristics

5.3 ESD Tolerance

ESD protection for FT2233HP/FT2232HP IO's

Parameter	Reference	Minimum	Typical	Maximum	Units
Human Body Model (HBM)	ANSI/ESDA/JEDEC JS-001 Class 2		±2kV		kV
Machine Mode (MM)	JEDEC EIA/JESD22-A115-C, Class B		±200V		V
Charge Device Model (CDM)	ANSI/ESDA/JEDEC JS-002, JEDEC JESD22-C101-D Class-III		±500V		V
Latch-up	JEDEC STANDARD EIA/JESD78, Trigger Class-II		±200mA		mA

Table 37 – ESD Tolerance

6 Package Parameters

The FT2233HP / FT2232HP is available in three different packages. The FT2233HPL is the LQFP-80 package option, the FT2233HPQ is the QFN-76 package option and the FT2232HPQ is the QFN-68 package option. See TN_166 [FTDI Example IC Footprints](#) for PCB footprint guidelines.

6.1 FT2233HPL, LQFP-80 Package Dimensions

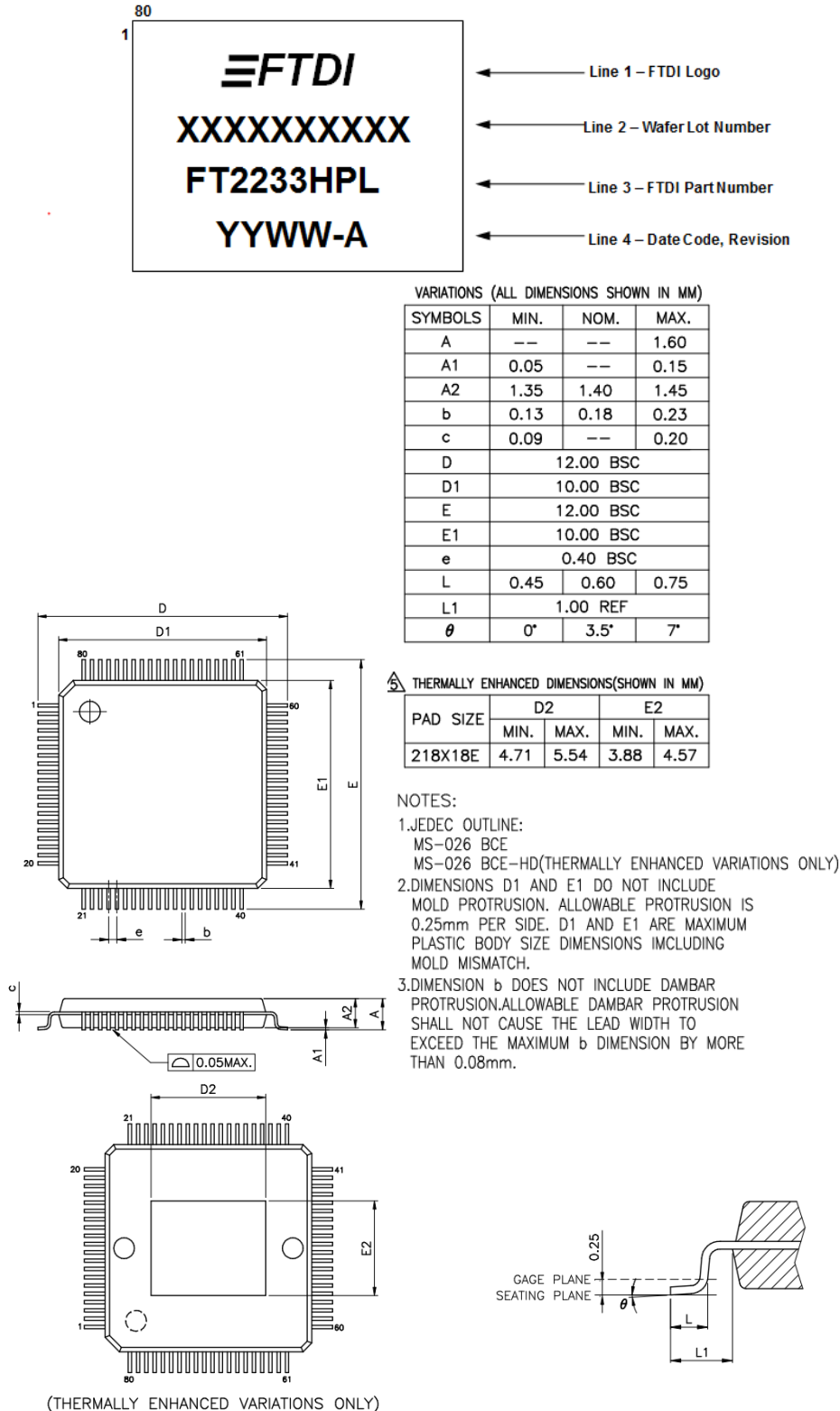
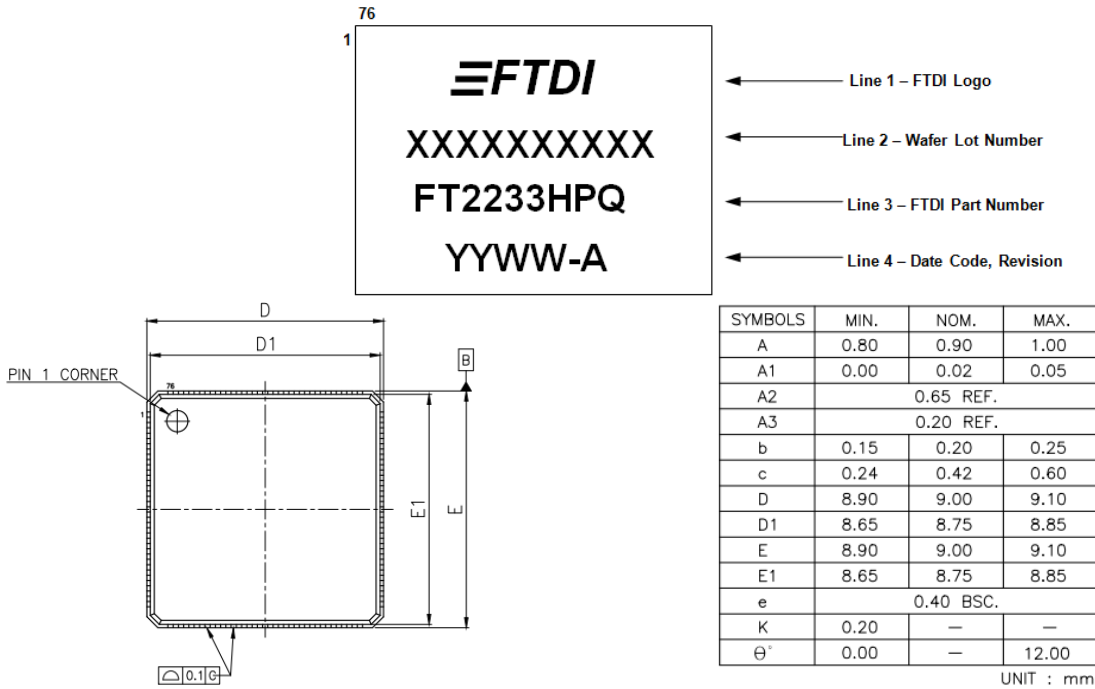

Figure 30 - 80 Pin LQFP Package Details

6.2 FT2233HPQ, QFN-76 Package Dimensions



UNIT : mm	EXPOSED PAD						L		
	D2			E2			MIN.	NOM.	MAX.
PAD SIZE	MIN.	NOM.	MAX.	MIN.	NOM.	MAX.			
245X26* MIL	5.56	5.81	6.06	6.06	6.31	6.56	0.30	0.40	0.50

△ "*"表示汎用字元,此汎用字元可能被其它不同字元所取代,實際的字元請參照bonding diagram所示。
△ "*" is an universal character, which means maybe replaced by specific character, the actual character please refers to the bonding diagram.

- NOTES :
1. JEDEC : N/A.
 2. DIE THICKNESS ALLOWABLE IS 0.305mm MAXIMUM (0.012 INCHES MAXIMUM).
 3. DIMENSION "b" APPLIES TO PLATED TERMINAL AND IS MEASURED BETWEEN 0.2 AND 0.25mm FROM TERMINAL TIP.
 4. THE PIN #1 IDENTIFIER MUST BE PLACED ON THE TOP SURFACE OF THE PACKAGE BY USING INDENTATION MARK OR OTHER FEATURE OF PACKAGE BODY.
 5. THE PIN #1 IDENTIFIER EXACT SHAPE AND SIZE OF THIS FEATURE IS OPTIONAL.
 6. APPLIED FOR EXPOSED PAD AND TERMINALS. EXCLUDE EMBEDDING PART OF EXPOSED PAD FROM MEASURING.
 7. DIMENSION "A1" APPLIED ONLY TO TERMINALS.
 8. EXACT SHAPE OF EACH CORNER IS OPTIONAL.

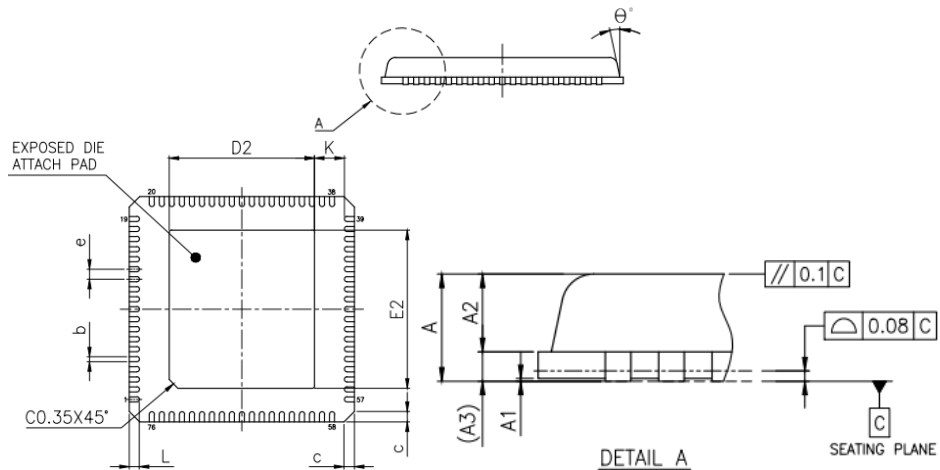

Figure 31 - Pin QFN Package Details

6.3 FT2232HPQ, QFN-68 Package Dimensions

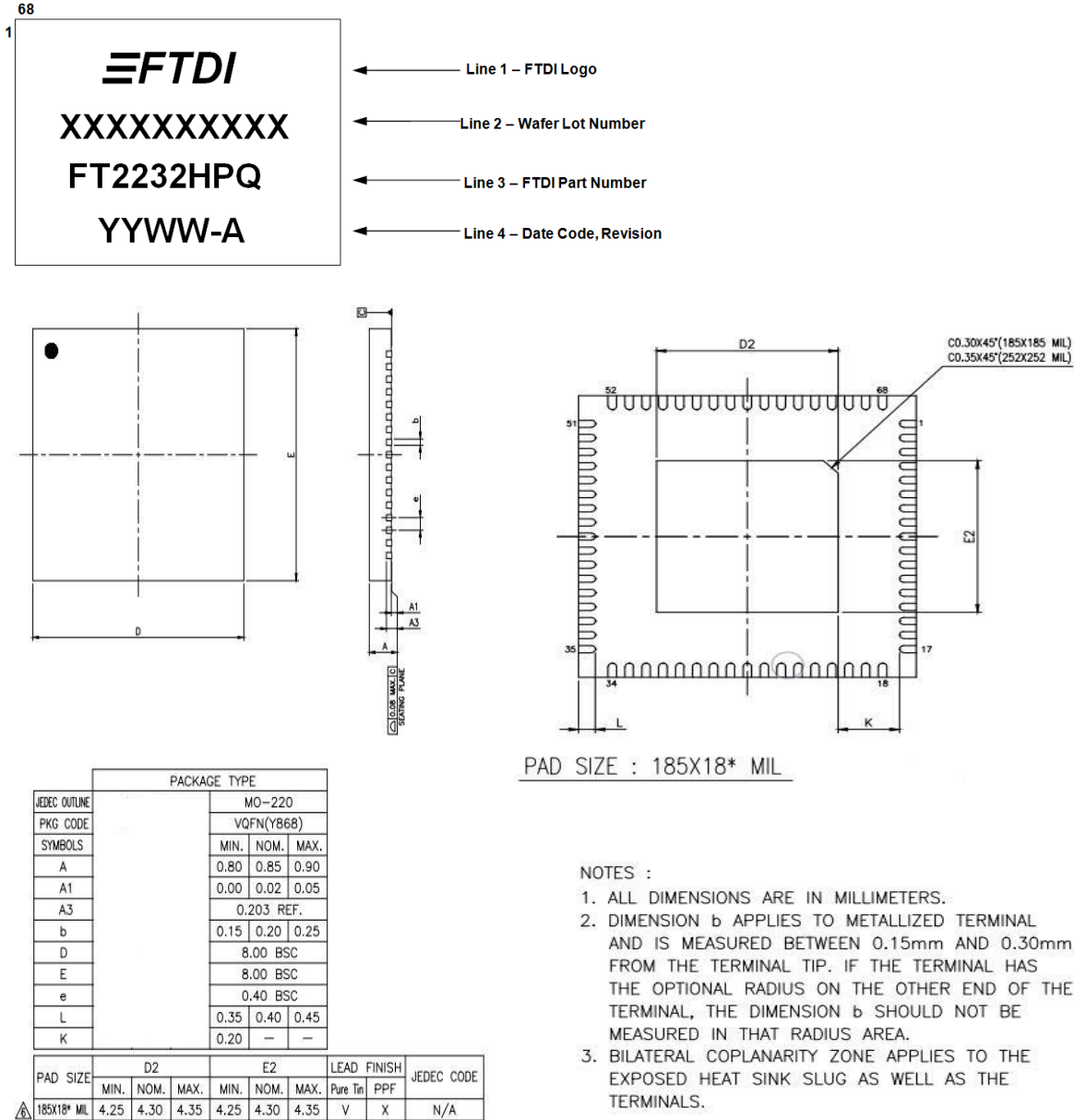

Figure 32 - 68 Pin QFN Package Details

7 FT2233HP/FT2232HP Configuration

7.1 Oscillator Configuration

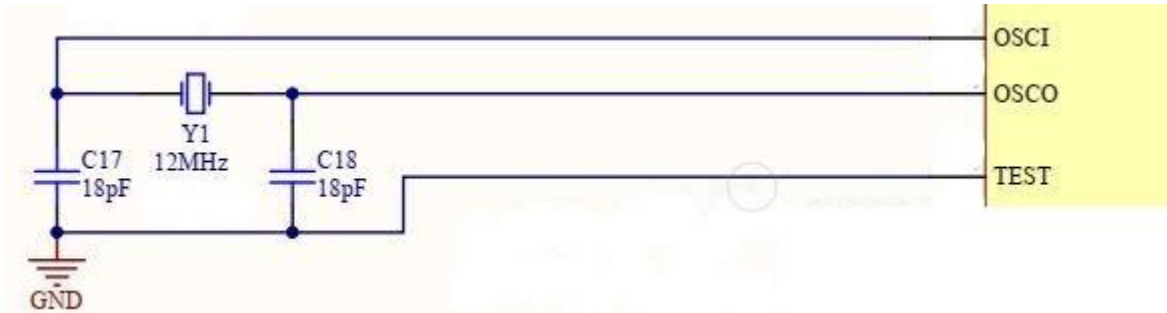

Figure 33 - Recommended FT2233HP/FT2232HP Crystal Oscillator Configuration

Figure 33 illustrates how to connect the FT2233HP/FT2232HP with a 12MHz $\pm 0.003\%$ crystal. In this case loading capacitors should be added between OSCI, OSCO and GND as shown. A value of 18pF is shown as the capacitor in the example – this will be good for many crystals, but it is recommended to select the loading capacitor value based on the manufacturer’s recommendations wherever possible. It is recommended to use a parallel cut type crystal.

It is also possible to use a 12 MHz oscillator with the FT2233HP/FT2232HP. In this case the output of the oscillator would drive OSCI, and OSCO should be left unconnected. The oscillator must have a CMOS output drive capability.

Item / Type	7B	7B(T)
Frequency Tolerance (at 25 °C)	± 30 ppm	± 10 ppm
Frequency Stability Over Operating Temperature Range	± 30 ppm	± 10 ppm
Shunt Capacitance (C0)	5 pF Max. (2 pF typical)	
Drive Level	1 ~ 200 μ W (100 μ W typical)	
Load Capacitance	10 pF, 16 pF, 20 pF, or specify	6 pF, 9 pF, 10 pF, 12 pF, 16 pF

Table 38 - Crystal Characteristics

8 EEPROM Configuration

If an external EEPROM is fitted (93LC66) it can be programmed over USB using [FT_PROG](#). The EEPROM must be 16 bits wide and capable of working at a VCC supply of +3.0 to +3.6 volts.

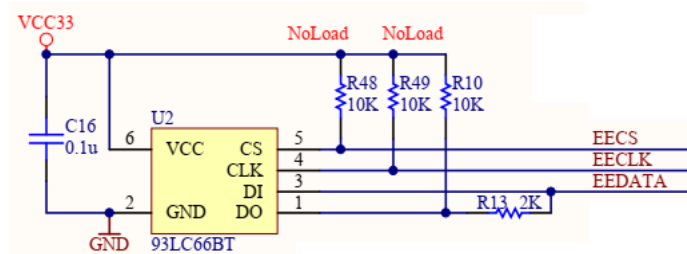

Figure 35 - EEPROM Interface

The external EEPROM can also be used to customise the USB VID, PID, Serial Number, Product Description Strings and Power Descriptor value of the FT2233HP/FT2232HP for OEM applications. Other parameters controlled by the EEPROM include Remote Wake Up, Soft Pull Down on Power-Off and I/O pin drive strength selection.

If no EEPROM is connected (or the EEPROM is blank), the FT2233HP/FT2232HP uses its built-in default VID (0403), PID (6040/6042) Product Description and Power Descriptor Value. In this case, the device will not have a serial number as part of the USB descriptor.

8.1 Default EEPROM Configuration

The external EEPROM (if it's fitted) can be programmed over USB using [FT_PROG](#). This allows a blank part to be soldered onto the PCB and programmed as part of the manufacturing and test process. Users who do not have their own USB Vendor ID but who would like to use a unique Product ID in their design can apply to FTDI for a free block of unique PIDs.

See [TN_100 USB Vendor ID/Product ID Guidelines](#) for more information.

Parameter	Value	Notes
USB Vendor ID (VID)	0403h	FTDI default VID (hex)
USB Product ID (PID)	6040h 6042h	FTDI default PID (hex) for FT2233HP FTDI default PID (hex) for FT2232HP
bcd Device	0x2800 0x3000	for FT2233HP for FT2232HP
Serial Number Enabled?	Yes	
Serial Number	None	
Pull down I/O Pins in USB Suspend	Disabled	Enabling this option will make the device pull down on the UART interface lines when in USB suspend mode (PWREN# is high).
Manufacturer Name	FTDI	
Product Description	Dual RS232-HS	
Max Bus Power Current	500mA	
Power Source	Bus Powered	
Device Type	FT2233HP FT2232HP	for FT2233HP for FT2232HP
USB Version	0200h	Returns USB 2.0 device description to the host.
Remote Wake Up	Disabled	Taking RI# low will wake up the USB host controller from suspend in approximately 20 ms. If enabled.
Hardware Interface	UART	Allows user to select the hardware mode of the device. Options include RS232 UART, 245 FIFO, CPU 245 and OPTO Isolate.
High Current I/Os	Disabled	Enables the high drive level on the UART and ACBUS I/O pins.

Parameter	Value	Notes
IO Slew	Disabled	Slow slew rate if enabled
Schmitt Trigger for Input pin	Normal trigger	Schmitt trigger for input pin if enabled
Load VCP Driver	Enabled	Makes the device load the VCP driver interface for the device.

Table 39 - Default Configuration with a blank/no EEPROM

8.2 PD Configuration and Default values

Refer to [AN 448 FT4233HP FT2233HP FT233HP Configuration Guide](#) for FT2233HP Power Delivery configuration and Default values.

Refer to [AN 551 FT4232HP FT2232HP FT232HP Configuration Guide](#) for FT2232HP Power Delivery configuration and Default values.

9 Contact Information

Head Office – Glasgow, UK

Future Technology Devices International Limited
Unit 1, 2 Seaward Place, Centurion Business Park
Glasgow G41 1HH
United Kingdom
Tel: +44 (0) 141 429 2777
Fax: +44 (0) 141 429 2758

E-mail (Sales) sales1@ftdichip.com
E-mail (Support) support1@ftdichip.com
E-mail (General Enquiries) admin1@ftdichip.com

Branch Office – Tigard, Oregon, USA

Future Technology Devices International Limited (USA)
7130 SW Fir Loop
Tigard, OR 97223-8160
USA
Tel: +1 (503) 547 0988
Fax: +1 (503) 547 0987

E-mail (Sales) us.sales@ftdichip.com
E-mail (Support) us.support@ftdichip.com
E-mail (General Enquiries) us.admin@ftdichip.com

Branch Office – Taipei, Taiwan

Future Technology Devices International Limited (Taiwan)
2F, No. 516, Sec. 1, NeiHu Road
Taipei 114
Taiwan, R.O.C.
Tel: +886 (0) 2 8797 1330
Fax: +886 (0) 2 8751 9737

E-mail (Sales) tw.sales1@ftdichip.com
E-mail (Support) tw.support1@ftdichip.com
E-mail (General Enquiries) tw.admin1@ftdichip.com

Branch Office – Shanghai, China

Future Technology Devices International Limited (China)
Room 1103, No. 666 West Huaihai Road,
Shanghai, 200052
China
Tel: +86 21 62351596
Fax: +86 21 62351595

E-mail (Sales) cn.sales@ftdichip.com
E-mail (Support) cn.support@ftdichip.com
E-mail (General Enquiries) cn.admin@ftdichip.com

Web Site

<https://ftdichip.com/>

Distributor and Sales Representatives

Please visit the Sales Network page of the [FTDI Web site](#) for the contact details of our distributor(s) and sales representative(s) in your country.

System and equipment manufacturers and designers are responsible to ensure that their systems, and any Future Technology Devices International Ltd (FTDI) devices incorporated in their systems, meet all applicable safety, regulatory and system-level performance requirements. All application-related information in this document (including application descriptions, suggested FTDI devices and other materials) is provided for reference only. While FTDI has taken care to assure it is accurate, this information is subject to customer confirmation, and FTDI disclaims all liability for system designs and for any applications assistance provided by FTDI. Use of FTDI devices in life support and/or safety applications is entirely at the user's risk, and the user agrees to defend, indemnify, and hold harmless FTDI from any and all damages, claims, suits, or expense resulting from such use. This document is subject to change without notice. No freedom to use patents or other intellectual property rights is implied by the publication of this document. Neither the whole nor any part of the information contained in, or the product described in this document, may be adapted, or reproduced in any material or electronic form without the prior written consent of the copyright holder. Future Technology Devices International Ltd, Unit 1, 2 Seaward Place, Centurion Business Park, Glasgow G41 1HH, United Kingdom. Scotland Registered Company Number: SC136640

Appendix A – References

Document References

[AN_177 User Guide For libMPSSE-I2C](#)
[AN_178 User Guide For libMPSSE-SPI](#)
[AN_113 Interfacing FT2232H Hi-Speed Devices To I2C Bus](#)
[AN_114 Interfacing FT2232H Hi-Speed Devices To SPI Bus](#)
[AN_1-0 - Programmers Guide for High Speed FTCJTAG DLL](#)
[AN_135 MPSSE Basics](#)
[AN_108 Command Processor for MPSSE and MCU Host Bus Emulation Modes](#)
[TN_104 Guide to Debugging Customers Failed Driver Installation](#)
[TN_100 USB Vendor ID/Product ID Guidelines](#)
[AN_4-1 - FTx232H MPSSE I2C Master Example in C#](#)
[TN_166 FTDI Example IC Footprints](#)
[AN2232--2 - Bit Mode Functions for the FT2232 74HC595 datasheet](#)
[FT_PROG EEPROM Programming Utility](#)
[AN_448 FT4233HP_FT2233HP_FT233HP Configuration Guide](#)
[AN_551 FT4232HP_FT2232HP_FT232HP Configuration Guide](#)
[AN_449 FT4233HP_FT2233HP_FT4232HP_FT2232HP DCDC Power Delivery](#)
[TN_180 FT4233HP_FT2233HP_FT233HP Errata Technical Note](#)
[Evaluation Modules](#)

Acronyms and Abbreviations

Terms	Description
DRP	Dual Role Power
EEPROM	Electrically Erasable Programmable Read-Only Memory
FIFO	First In First Out
FPGA	Field-Programmable Gate Array
IC	Integrated Circuit
I2C	Inter Integrated Circuit
JTAG	Joint Test Action Group
LDO	Low Drop Out
LED	Light Emitting Diode
MCU	Microcontroller Unit
MPSSE	Multi-Protocol Synchronous Serial Engine
PD	Power Delivery
PLD	Programmable Logic Device
QFN	Quad Flat No-Lead
SPI	Serial Peripheral Interface
USB	Universal Serial Bus
UART	Universal Asynchronous Receiver/Transmitter
UTMI	Universal Transceiver Macrocell Interface
VCP	Virtual COM Ports

Appendix B – List of Tables and Figures

List of Tables

Table 1 – FT2233HP/FT2232HP Pin Description.....	11
Table 2 – Power and Ground Pins.....	12
Table 3 – Common Function Pins	12
Table 4 – EEPROM Interface Pins	12
Table 5 – Type-C/PD Port Pins.....	12
Table 6 – GPIO Pins	13
Table 7 – Channel A & B RS232 Configured Pin Descriptions	13
Table 8 – Channel A FT245 Style Synchronous FIFO Configured Pin Descriptions	14
Table 9 – Channel A & B FT245 Style Asynchronous FIFO Configured Pin Descriptions	15
Table 10 – Channel A & B Synchronous or Asynchronous Bit-Bang Configured Pin Description	16
Table 11 – Channel B Fast Series Interface Configured Pin Descriptions.....	17
Table 12 – Channel A & B CPU-Style FIFO Interface Configured Pin Descriptions.....	17
Table 13 – Channel A & B MPSSE Configured Pin Descriptions	18
Table 14 – Channel A & B Host Bus Emulation Interface Configured Pin Descriptions	18
Table 15 – FT245 Synchronous FIFO Interface Signal Timings	25
Table 16 – Asynchronous FIFO Timings (based on standard drive level outputs)	26
Table 17 – MPSSE Signal Timings	27
Table 18 – MCU Host Bus Emulation Mode Signal Timings – WRITE Cycle	29
Table 19 – MCU Host Bus Emulation Mode Signal Timings – READ Cycle	30
Table 20 – Fast Opto-Isolated Serial Interface Signal Timings	31
Table 21 – CPU-Style FIFO Interface Operation Select	33
Table 22 – CPU-Style FIFO Interface Operation Read Status Description	33
Table 23 – CPU-Style FIFO Interface Operation Signal Timing.....	33
Table 24 – Synchronous Bit-Bang Mode Timing Interface Example Timings	35
Table 25 – Configuration Using EEPROM and Application Software	38
Table 26 – AC Timing on GPIO	39
Table 27 – Example GPIO States for Power Control	39
Table 28 – CC Voltages on Source Side – Default USB.....	40
Table 29 – CC Voltages on Source Side – 1.5A @ 5V.....	40
Table 30 – CC Voltages on Source Side – 3A @ 5V.....	40
Table 31 – Schottky Diode Recommended Characteristics	40
Table 32 – Absolute Maximum Ratings	41
Table 33 – Operating Voltage and Current	41
Table 34 – I/O Pin Characteristics (except USB PHY pins)	42
Table 35 – PHY Operating Voltage and Current.....	42
Table 36 – PHY I/O Pin Characteristics.....	43
Table 37 – ESD Tolerance	43
Table 38 - Crystal Characteristics	47
Table 39 - Default Configuration with a blank/no EEPROM.....	50

List of Figures

Figure 1 – FT2233HP Block Diagram	4
Figure 2 – Pin Configuration QFN-76 (Top View)	7
Figure 3 – Pin Configuration QFN-68 (Top View)	8
Figure 4 – Pin Configuration LQFN-80 (Top View).....	9
Figure 5 – Single RS232 Configurations	21
Figure 6 – Dual RS422 Configurations	22
Figure 7 – Dual RS485 Configurations	23
Figure 8 – FT245 Synchronous FIFO Interface Signal Waveforms	24
Figure 9 – FT245 Asynchronous FIFO Interface READ Signal Waveforms.....	25
Figure 10 – FT245 Asynchronous FIFO Interface WRITE Signal Waveforms	26
Figure 11 – MPSSE Signal Waveforms	27
Figure 12 – Adaptive Clocking Interconnect.....	27
Figure 13 – Adaptive Clocking Waveform	28
Figure 14 – MCU Host Bus Emulation Mode Signal Waveforms – WRITE Cycle	29
Figure 15 – MCU Host Bus Emulation Mode Signal Waveforms – READ Cycle	29
Figure 16 – MCU Host Emulation Example using a CANBus Controller.....	30
Figure 17 – Fast Opto-Isolated Serial Interface Signal Waveforms	31
Figure 18 – Fast Opto-Isolated Serial Interface Output Data	31
Figure 19 – Fast Opto-Isolated Serial Interface Input Data.....	32
Figure 20 – Fast Opto-Isolated Serial Interface Example.....	32
Figure 21 – CPU-Style FIFO Interface Operation Signal Waveforms	33
Figure 22 – CPU-Style FIFO Interface Example	34
Figure 23 – Synchronous Bit-Bang Mode Timing Interface Example.....	35
Figure 24 – Bit-Bang Mode Dataflow Illustration Diagram	36
Figure 25 – Dual LED UART Configuration	36
Figure 26 – Single LED UART Configuration	36
Figure 27 – Using SIWU#	37
Figure 28 – General PD Working Diagram	38
Figure 29 – Schottky Diode Equivalent Circuit	40
Figure 30 - 80 Pin LQFP Package Details	44
Figure 31 - Pin QFN Package Details.....	45
Figure 32 - 68 Pin QFN Package Details	46
Figure 33 - Recommended FT2233HP/FT2232HP Crystal Oscillator Configuration	47
Figure 34 - Bus Powered PD Configuration Diagram	48
Figure 35 - EEPROM Interface	49