

POWER RELAY

1 POLE - 30A DC Relay

2 x 3.2mm contact gap

FTR-K2W Series

■ FEATURES

- Contact rating: 60VDC, 30A; 72VDC, 25A
- Wide contact gap: 2 x 3.2mm
- Compact size: 36.5 (L) x 34.9 (W) x 30.2 (H) mm
- 1 form A contact
- High insulation (between coil and contact)
 - Insulation distance: Clearance > 8.0mm
Creepage > 9.5mm
 - Dielectric strength: 5,000VAC
 - Surge strength: 10,000V
- Flammability UL94V-0 (plastics)
- RoHS compliant
Please see page 6 for more information



■ PARTNUMBER INFORMATION

[Example] FTR-K2W A K 012 W
 (a) (b) (c) (d) (e)

(a)	Relay type	FTR-K2W : FTR-K2W-Series
(b)	Contact configuration	A : 1 form A
(c)	Coil type	K : Standard (2,000mW)
(d)	Coil rated voltage	12 : 5.....48 VDC Coil rating table at page 3
(e)	Contact material	W : Silver alloy

Actual marking does not carry the type name : "FTR"
 E.g.: Ordering code: FTR-K2WAK012W Actual marking: K2WAK012W

FTR-K2W SERIES

■ SPECIFICATION

Item			FTR-K2W
Contact Data	Configuration		1 form A
	Material		Silver alloy
	Resistance (initial)		Max. 100mOhm at 1A, 6VDC
	Contact rating		30A / 60VDC, 25A / 72VDC (resistive)
Life	Mechanical		Min. 1 x 10 ⁶ operations
	Electrical		10 x 10 ³ operations
Coil Data	Rated power (at 20 °C)		Approximately 2,000mW
	Nominal voltage		5, 12, 24, 48VDC
	Operating temperature range		-40 °C to +70 °C (no frost)
Timing Data	Operate (at nominal voltage)		Max. 30ms (without bounce)
	Release		Max. 15ms (no diode)
Insulation	Resistance (initial)		Min. 1,000MOhm at 500VDC
	Dielectric strength	Open contacts	2,000VAC (50/60 Hz) 1min.
		Coil and contacts	5,000VAC (50/60 Hz) 1min.
	Surge strength	Coil to contacts	10,000V / 1.2 x 50µs standard wave
	Clearance		≥ 8 mm
Creepage		≥ 9.5 mm	
Other	Vibration resistance	Misoperation	10 to 55Hz double amplitude 1.5 mm
		Endurance	10 to 55Hz double amplitude 1.5 mm
	Shock resistance	Misoperation	Min. 100m/s ² (11 ± 1ms)
		Endurance	Min. 1,000m/s ² (6 ± 1ms)
	Weight		Approximately 74 g
Sealing		Flux proof, RT II	

Notes:

1. To prevent hazardous situation in case of catastrophic contact failures like contact welding, please carefully evaluate the relay application parameters, to assure a fail-safe design. This is particularly important in case of over spec use and long periods of continuous use.
2. Use of a varistor in parallel over the coil is recommended to clamp reverse inductive voltage surges. Reverse blocking voltage should be about 3 times the surge voltage level.
3. A contact carrying currents higher than 10A, it is recommended to consider addition heat develop in the PCB contact tracks.
4. Specified values are valid in case of series connection of coils, by connecting pin 2 and 3, at Tamb 20°C and at zero contact current.

■ COIL RATING

Coil Code	Rated Coil Voltage (VDC)	Coil Resistance +/- 10% (Ohm)	Must Operate Voltage (VDC) *	Must Release-Voltage (VDC) *	Rated Power +/- 10% (mW)
005	5	12.5	3.25	0.25	Approx. 2,000
012	12	72	7.8	0.6	
024	24	290	15.6	1.2	
048	48	1,160	31.2	2.4	

Notes:

- 1) Specified values are valid in case of series connection of coils, by connecting pin 2 and 3, at Tamb 20°C and at zero contact current.
- 2) Normal use it at nominal coil voltage. If the relay is energized at higher coil voltage, refer to data "coil temperature rise"

*Specified operate- and must release voltage are valid for pulse wave voltages.

■ SAFETY STANDARDS

Type	Compliance	Contact rating
UL	UL 508 CSA22.2 No. 14-05	30A, 60VDC, resistive, 10,000 cycles
TUV	EN61810-1 / IEC61810-1	30A, 60VDC, resistive, 10,000 cycles

FTR-K2W SERIES

CHARACTERISTIC DATA

The graphs are based on measurement data and are typical values.

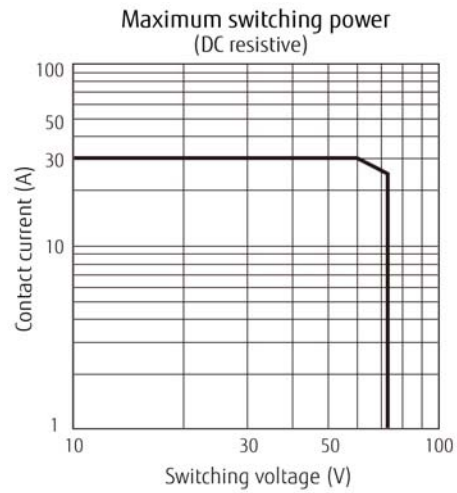
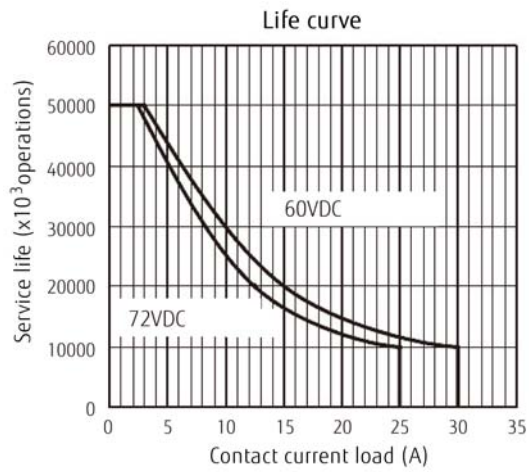
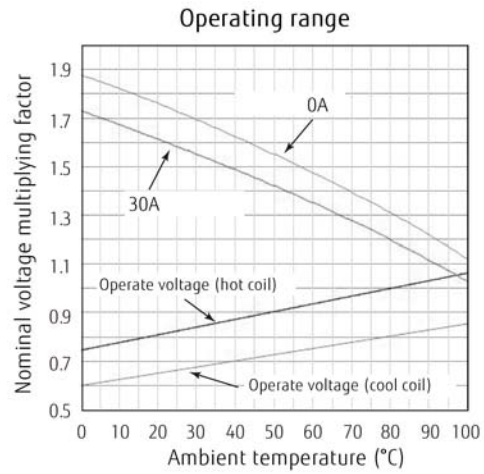
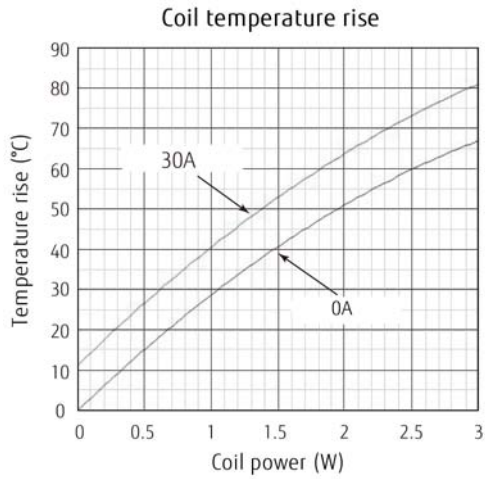

Please use this graph for reference purposes only

■ DIMENSIONS

● Dimensions

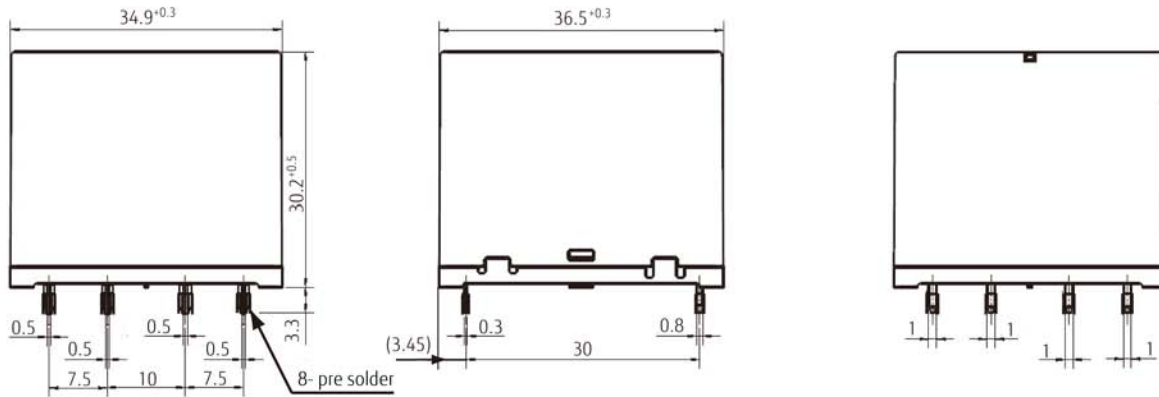

● Schematics (BOTTOM VIEW)

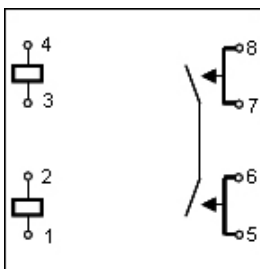

● Circuit (BOTTOM VIEW)

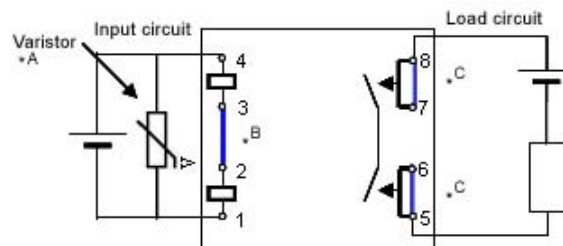

● PC board pattern (BOTTOM VIEW)

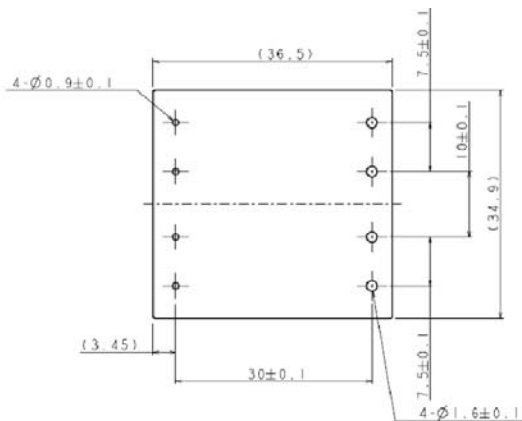

Notes:

- A. Use of a varistor in parallel over the coil is recommended to clamp reverse inductive voltage surges. Reverse blocking voltage should be about 3 times the surge voltage level.
- B. Connect pin 2 and 3 to connect coils in series.
- C. To enhance a current carry capability, connect pin 5 with 6 and pin 7 with 8.
- D. Coils are polarity insensitive.

Unit: mm

RoHS Compliance and Lead Free Information

1. General Information

- All relays produced by Fujitsu Components are compliant with RoHS directive 2011/65/EU including amendments.
- Cadmium as used in electrical contacts is exempted from the RoHS directives.
As per Annex III of directive 2011/65/EU.
- All relays are lead-free. Please refer to Lead-Free Status Info for older date codes at:
<http://www.fujitsu.com/downloads/MICRO/fcai/relays/lead-free-letter.pdf>
- Lead free solder plating on relay terminals is Sn-3.0Ag-0.5Cu, unless otherwise specified.
This material has been verified to be compatible with PbSn assembly process.

2. Recommended Lead Free Solder Condition

- Recommended solder Sn-3.0Ag-0.5Cu.

Flow Solder Condition:

Pre-heating: maximum 120 °C
within 90 sec.
Soldering: dip within 5 sec. at
255 °C ± 5 °C solder bath
Relay must be cooled by air immediately
after soldering

Solder by Soldering Iron:

Soldering Iron 30-60W
Temperature: maximum 350-360 °C
Duration: maximum 3 sec.

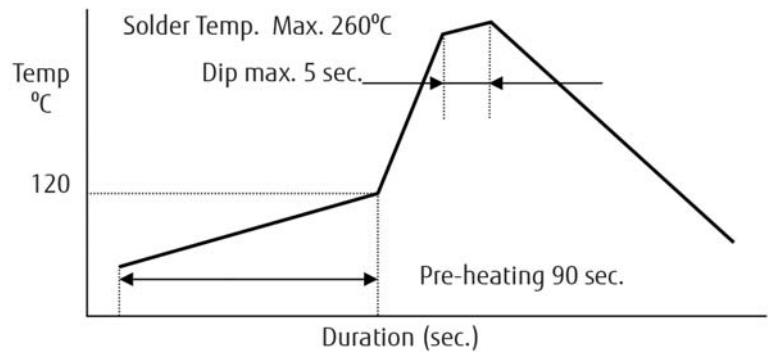

We highly recommend that you confirm your actual solder conditions

3. Moisture Sensitivity

- Moisture Sensitivity Level standard is not applicable to electromechanical relays, unless otherwise indicated.

4. Tin Whiskers

- Dipped SnAgCu solder is known as presenting a low risk to tin whisker development. No considerable length whisker was found by our in house test.