

COMPACT POWER RELAY

1 POLE - 210A Battery Latching relay

FTR-V1 Series

■ FEATURES

- 1 pole 210A 1 form B relay for 12V car battery
- Low profile
- Double winding latching relay
- 210A (at 85 °C) / 120A (at 125 °C) continuous current
- Low contact resistance: Max. 0.6mΩ (initial, at 1A)
- Ambient temperature up to 125 °C)
- Plastic sealed
- Plastic material: Conforms to UL94V-0 flammability



■ Applications

Disconnect of battery / capacitor, protection of battery / capacitor, switch of 2 power supplies.

■ PARTNUMBER INFORMATION

[Example] FTR-V1 U C 012 W ST
 (a) (b) (c) (d) (e) (f)

(a)	Relay type	FTR-V1	: FTR-V1 Series
(b)	Contact configuration	U	: 1b (1 form B)
(c)	Coil type	C	: Dual coil latching
(d)	Coil voltage	012	: 12VDC
(e)	Contact material	W	: Silver alloy
(f)	Special type	ST	: Standard

Actual marking does not carry the type name: "FTR"
 E.g.: Ordering code: FTR-V1UC012W Actual marking: V1UC012W

FTR-V1 SERIES

■ SPECIFICATION

Item	FTR-V1		
Contact Data	Configuration	1b (1 form B)	
	Material	Silver alloy	
	Construction	Twin	
	Contact rating	Inrush: 230A 14VDC Break:1A 14VDC	
	Contact voltage drop (initial)	Max. 0.6mV at 1A 6VDC	
	Contact resistance (initial)	Max. 0.6mΩ at 1A 6VDC	
	Continuous current	210A (at 85 degC, cable size 38mm ²) 120A (at 125 degC, cable size 38mm ²)	
	Max. breaking current	500A 12VDC resistive, 1,000 operations	
	Min. switching load *	6VDC, 1A (reference)	
Life	Mechanical	200 x 10 ³ operations	
	Electrical	120 x 10 ³ operations (Inrush :230A 14VDC / Break:1A 14VDC)	
Coil data	Operating ambient temperature range	-40 degC to +125 degC (no frost)	
	Rated power consumption	28.8W (at nominal voltage, at 20 degC)	
	Pulse width	50 to 100ms	
Timing Data	Set (at nominal voltage, at 20 degC)	Max. 10ms (without bounce)	
	Reset (at nominal voltage, at 20 degC)	Max. 10ms (without bounce)	
Insulation	Resistance (initial)	100M Ω at 500VAC	
	Dielectric withstand- ing voltage (initial)	Between open contacts	500VAC(50/60Hz), 1 minute
		Between coil-contact	500VAC(50/60Hz), 1 minute
Other	Vibration resistance	Misoperation	10 to 200Hz, acceleration 45m/s ² , constant acceleration (Detection 1ms, set/reset)
		Endurance	10 to 200Hz, acceleration 45m/s ² , constant acceleration (Set/reset, up/down 4 hours, left/right 2 hours)
	Shock resistance	Misoperation	Min. 100m/s ² (11±1ms) (Detection 1ms, set/reset 36 times each)
		Endurance	Min. 1,000m/s ² (6±1ms) (Set/reset 36 times total)
	Weight	Approximately 120 g	
	Sealing	Sealed, RT III	

Note: Values of electrical characteristics are under 15 to 35 degC, 25 to 75%RH, air pressure 86kPa to 106kPa (JIS standard condition) unless otherwise specified.

* : Minimum switching loads mentioned above are reference values. Please perform the confirmation test with actual load before production since reference values may vary according to switching frequencies, environmental conditions and expected reliability levels.

COIL RATING

Coil Code	Rated Coil Voltage (VDC)	Coil Resistance +/- 10% (Ohm)	Must Set / Reset Voltage (V) *
012	12	5	5.4 (20 °C)
			5.8 (85 °C)
			7.7 (125 °C)

Note: All values in the table are valid for 20°C and zero contact current, unless otherwise stated.

* Specified operate values are valid for pulse wave voltage.

CHARACTERISTIC DATA

Maximum Carrying Current

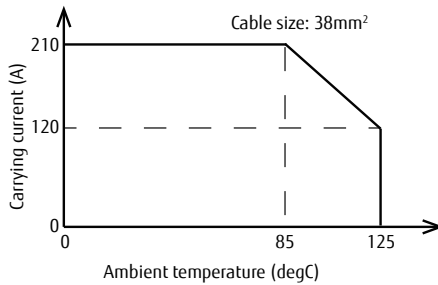

Distribution of set/reset voltage

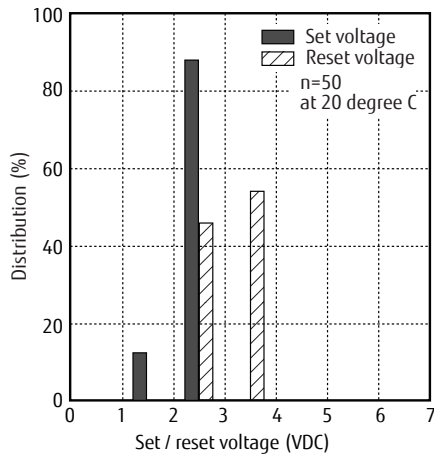

Distribution of contact voltage drop (contact resistance)

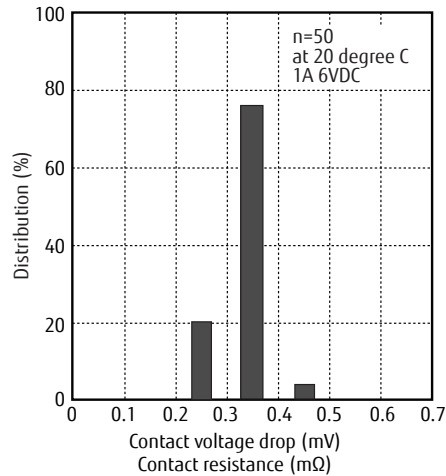

Distribution of set/reset time

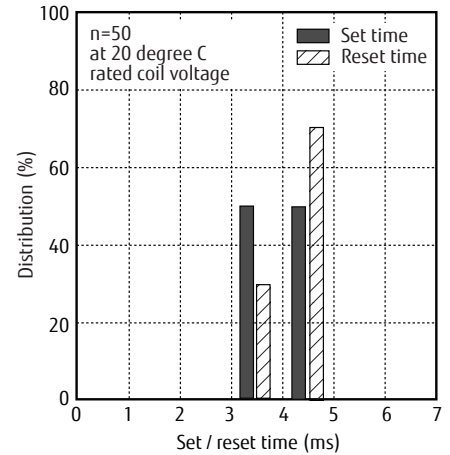

Shock resistance characteristics

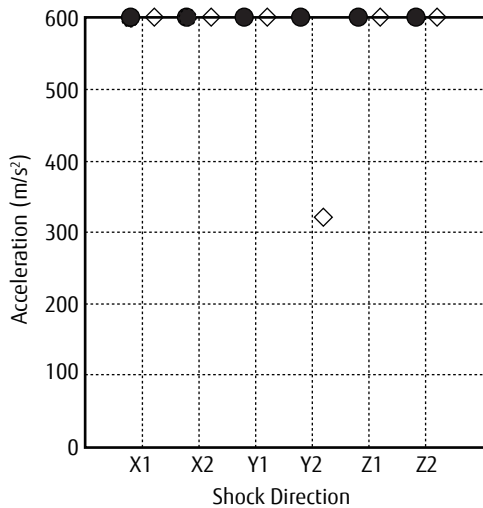

Half sine half wave pulse
 Shock application time: 11 ± 1 ms
 Detection level: chatter > 1 ms
 Shock direction: see below diagram

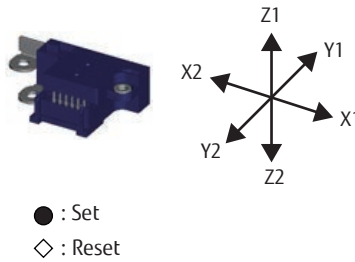

Notes for latching relay

- Latching relays are shipped in the state set, but state may change due to shock during transportation or mounting. Before using the relays, it is advisable to bring the relays in necessary state (set or reset) and program a circuit sequence. Otherwise, it will or will not operate simultaneously with power activation.
- Please connect relay coils according to specified polarity.
- Do not apply voltage to both set coil and reset coil at a time.

DIMENSIONS

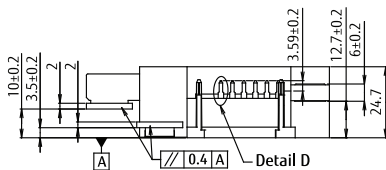
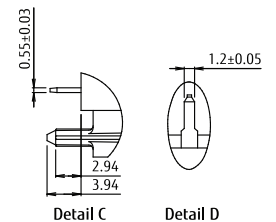
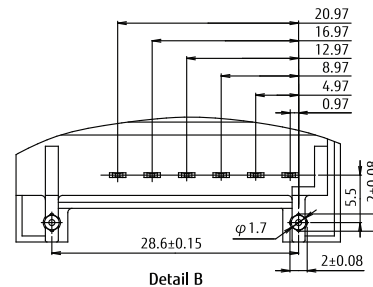
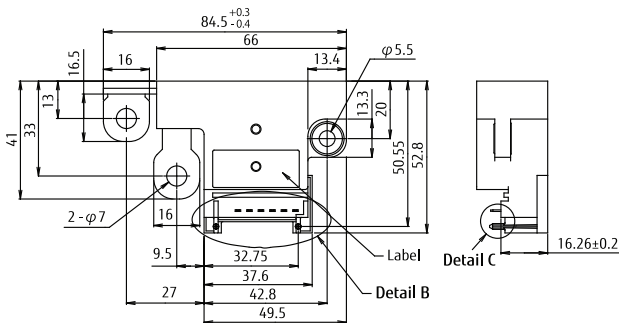

Tolerance : ± 0.3 mm unless otherwise specified
 Unit:mm

- **Schematics**
(BOTTOM VIEW)

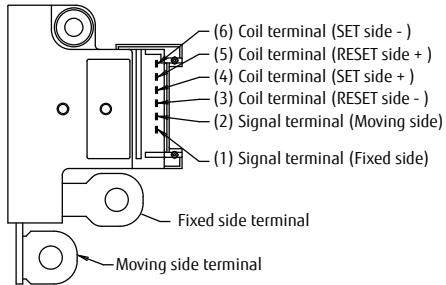

Circuit Diagram

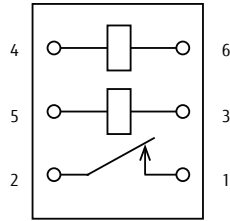

Circuit diagram shows set status.
Products are shipped in set status

(number) : Terminal number, corresponds to numbers on circuit diagram

Unit: mm

RoHS Compliance and Lead Free Information

1. General Information

- | All automotive relays produced by Fujitsu Components are compliant with RoHS directive 2002/95EC including amendments.
- | Lead free solder plating on relay terminals is Sn-3.0Ag-0.5Cu, unless otherwise specified. This material has been verified to be compatible with PbSn assembly process.

2. Recommended Lead Free Solder Profile

- | Recommended solder Sn-3.0Ag-0.5Cu.

Flow Solder condition:

Pre-heating: maximum 120°C
Soldering: dip within 5 sec. at
260°C solder bath

Solder by Soldering Iron:

Soldering Iron
Temperature: maximum 360°C
Duration: maximum 3 sec.

We highly recommend that you confirm your actual solder conditions

3. Moisture Sensitivity

- Moisture Sensitivity Level standard is not applicable to electromechanical relays, unless otherwise indicated.

4. Tin Whiskers

- Dipped SnAgCu solder is known as presenting a low risk to tin whisker development. No considerable length whisker was found by our in house test.