

FUSB3301

USB Type-C Controller for Mobile Chargers and Power Adapters

Description

The FUSB3301 is an autonomous Source only Type-C controller optimized for mobile chargers and power adapters. It broadcasts the available current of the charger over CC1/CC2 using the USB Type-C standard and prevents VBUS from being asserted until a valid connection has been verified. It can be used for up to 15 W charging using Type-C protocols. The FUSB3301 has very low standby power consumption and is packaged in a 0.5 mm pitch MLP to accommodate power adapter PCBs.

Features

- Fully Autonomous Type-C Controller
- Supports Type-C Version 1.2
- Fixed Source Mode
- Low Standby Power: $I_{CC} = 5 \mu\text{A}$ (Typical)
- VBUS Switch Control
- Advertises Three Standard Type-C VBUS Current Levels (900 mA, 1.5 A, 3.0 A)
- 2 kV HBM ESD Protection
- 10 Lead MLP Package
- V_{DD} Operating Range, 3.0 V – 5.5 V

Applications

- USB Type-C Power Ports
- Mobile Chargers
- Power Adapters
- AC-DC Adapters



ON Semiconductor®

www.onsemi.com

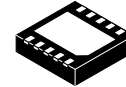

WDFN
10 LEAD
CASE 511DM

MARKING DIAGRAM



NZ = Specific Device Marking

PIN ASSIGNMENT

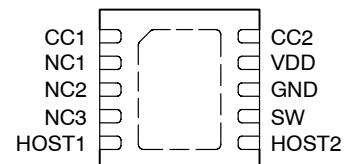

(Top View)

ORDERING INFORMATION

See detailed ordering and shipping information on page 2 of this data sheet.

FUSB3301

ORDERING INFORMATION

Part Number	Top Mark	Operating Temperature Range	Package	Packing Method
FUSB3301MPX	NZ	-40 to 85°C	10-Lead, MLP, 3 mm x 3 mm	Tape and Reel

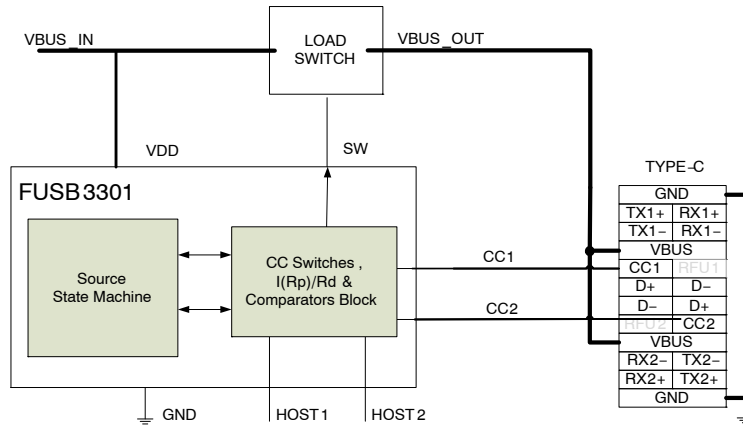

Figure 1. Block Diagram

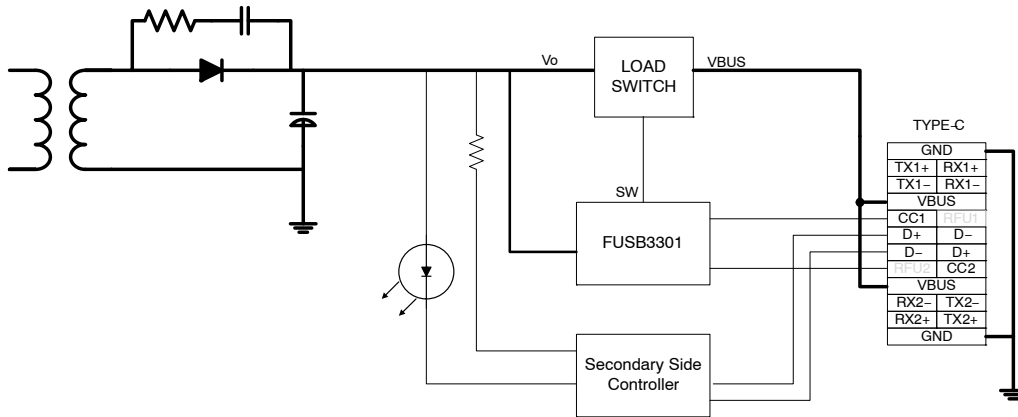

Figure 2. Typical Application

Table 1. PIN DESCRIPTIONS

Pin #	Name	Type	Description
1	CC1	Input/Output	Type-C Configuration Channel
2	NC1 (Note 1)	NC	No Connect
3	NC2 (Note 1)	NC	No Connect
4	NC3 (Note 1)	NC	No Connect
5	HOST1	Input	Host Current Select Pin with Internal Pull-up
6	HOST2	Input	Host Current Select Pin with Internal Pull-up
7	SW	Output	Open Drain output to control the VBUS load switch
8	GND	Power	Ground
9	VDD	Power	Power Supply
10	CC2	Input/Output	Type-C Configuration Channel

1. No connect pins can float or can be tied to ground.

FUSB3301

Table 2. CONNECTION STATE TABLE

CC1	CC2	SW	Description
NC	NC	HiZ	No Attach
Rd	NC	L	Attach to UFP (Sink)
NC	Rd	L	Attach to UFP (Sink)
Rd	Rd	HiZ	No Attach
Ra	NC	HiZ	No Attach
NC	Ra	HiZ	No Attach
Ra	Ra	HiZ	No Attach

Host Current

Table 3. HOST INPUT TRUTH TABLE

HOST2	HOST1	CC Current (μ A)	Host Current (A)
GND / LOW	GND / LOW	330	3.0
GND / LOW	FLOAT / HIGH	180	1.5
FLOAT / HIGH	GND / LOW	180	1.5
FLOAT / HIGH	FLOAT / HIGH	80	0.9

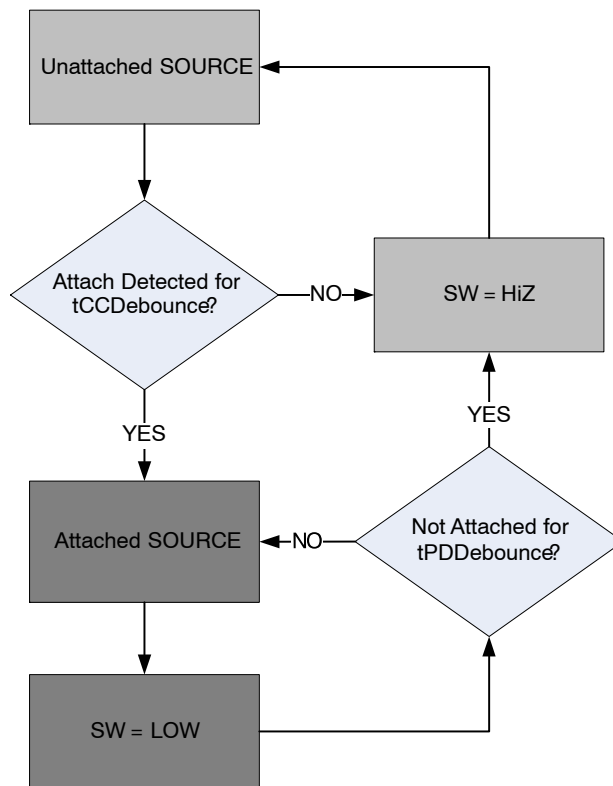

Figure 3. Source Attach Flowchart

FUSB3301

Table 4. ABSOLUTE MAXIMUM RATINGS

Symbol	Parameter		Min	Max	Unit	
V _{DD}	Supply Voltage		-0.5	6.0	V	
V _{CCX}	CC pins when configured as HOST		-0.5	6.0	V	
T _{STORAGE}	Storage Temperature Range		-65	+150	°C	
T _J	Maximum Junction Temperature			+150	°C	
T _L	Lead Temperature (Soldering, 10 seconds)			+260	°C	
ESD	IEC 61000-4-2 System ESD	Connector Pins (VBUS, CC1 & CC2)	Air Gap	15		kV
			Contact	8		
	Human Body Model, JEDEC JESD22-A114	Connector Pins (VBUS, CC1 and CC2)		4		kV
		Others		2		
	Charged Device Model, JEDEC JESD22-C101	All Pins	1		kV	

Stresses exceeding those listed in the Maximum Ratings table may damage the device. If any of these limits are exceeded, device functionality should not be assumed, damage may occur and reliability may be affected.

Table 5. RECOMMENDED OPERATING CONDITIONS

Symbol	Parameter	Min	Typ	Max	Unit
V _{DD}	Supply Voltage	3.0	5.0	5.5	V
T _A	Operating Ambient Temperature	-40		+85	°C
T _J	Operating Junction Temperature	-40		+125	°C

Functional operation above the stresses listed in the Recommended Operating Ranges is not implied. Extended exposure to stresses beyond the Recommended Operating Ranges limits may affect device reliability.

Table 6. DC AND TRANSIENT CHARACTERISTICS All typical values are at T_A=25°C unless otherwise specified.

Symbol	Parameter	T _A = -40 to +85°C T _J = -40 to +125°C			Unit
		Min	Typ	Max	
I _{80_CCX}	Source 80 μA CC Current (Default) HOST2=VDD, HOST1=VDD	64	80	96	μA
I _{180_CCX}	Source 180 μA CC Current (1.5 A) HOST2=VDD, HOST1=GND or HOST2=GND, HOST1=VDD	166	180	194	μA
I _{330_CCX}	Source 330 μA CC Current (3 A) HOST2=GND, HOST1=GND	304	330	356	μA
zOPEN	CC Resistance for Disabled State	126			kΩ
vRa-SRCdef	Ra Detection Threshold for CC Pin for Source for Default Current on VBUS	0.15	0.20	0.25	V
vRa-SRC1.5A	Ra Detection Threshold for CC pin for Source for 1.5 A Current on VBUS	0.35	0.40	0.45	V
vRa-SRC3A	Ra Detection Threshold for CC Pin for Source for 3 A Current on VBUS	0.75	0.80	0.85	V
vRd-SRCdef	Rd Detection Threshold for Source for Default Current (HOST2/1=VDD/VDD)	1.50	1.60	1.65	V
vRd-SRC1.5A	Rd detection threshold for Source for 1.5 A Current (HOST2/1=GND/VDD or VDD/GND)	1.50	1.60	1.65	V
vRd-SRC3A	Rd Detection Threshold for Source for 3 A Current (HOST2/1=GND/GND)	2.45	2.60	2.75	V

Product parametric performance is indicated in the Electrical Characteristics for the listed test conditions, unless otherwise noted. Product performance may not be indicated by the Electrical Characteristics if operated under different conditions.

FUSB3301

Table 7. CURRENT CONSUMPTION

Symbol	Parameter	Conditions	V _{DD} (V)	T _A = -40 to +85°C T _J = -40 to +125°C			Unit
				Min	Typ	Max	
I _{stby}	Unattached Source	Nothing attached, Host Pins = VDD, GND, Float.	3.0 to 5.5		5	20	μA
I _{attach}	Attach Current (Less Host Current)	Attached, Host Pins=VDD, GND, Float.	3.0 to 5.5		10	15	μA

Table 8. TIMING PARAMETERS

Symbol	Parameter	T _A = -40 to +85°C T _J = -40 to +125°C			Unit
		Min	Typ	Max	
t _{CCDebounce}	Time from CC Voltage Detection until SW goes LOW	100	150	200	ms
t _{PDDebounce}	Time from CC Voltage Not Detected until SW goes to High-Z	10	15	20	ms

Table 9. IO SPECIFICATIONS

Symbol	Parameter	Conditions	V _{DD} (V)	T _A = -40 to +85°C T _J = -40 to +125°C			Unit
				Min	Typ	Max	
V _{OLSW}	SW Output Low Voltage	I _{OL} =4 mA	3.0 to 5.5			0.4	V
V _{ILHOST}	HOST1/2 Low-Level Input Voltage		3.0 to 5.5			0.3V _{DD}	V
V _{IHHOST}	HOST1/2 High-Level Input Voltage		3.0 to 5.5	0.7V _{DD}			V



WDFN10 3x3, 0.5P
CASE 511DM
ISSUE O

DATE 31 AUG 2016

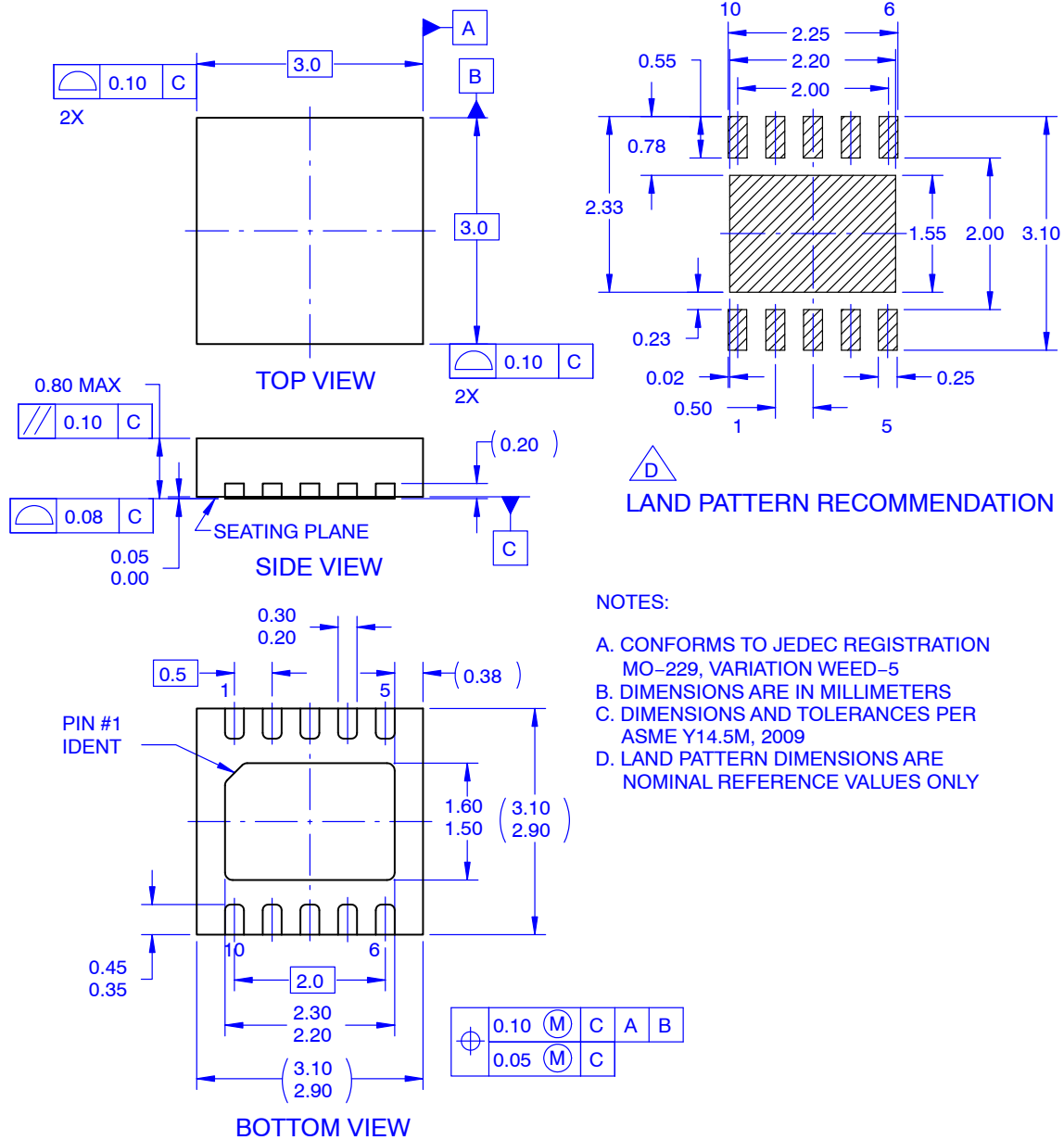

DOCUMENT NUMBER:	98AON13631G	Electronic versions are uncontrolled except when accessed directly from the Document Repository. Printed versions are uncontrolled except when stamped "CONTROLLED COPY" in red.
DESCRIPTION:	WDFN10 3X3, 0.5P	PAGE 1 OF 1

ON Semiconductor and are trademarks of Semiconductor Components Industries, LLC dba ON Semiconductor or its subsidiaries in the United States and/or other countries. ON Semiconductor reserves the right to make changes without further notice to any products herein. ON Semiconductor makes no warranty, representation or guarantee regarding the suitability of its products for any particular purpose, nor does ON Semiconductor assume any liability arising out of the application or use of any product or circuit, and specifically disclaims any and all liability, including without limitation special, consequential or incidental damages. ON Semiconductor does not convey any license under its patent rights nor the rights of others.