



## FX19

### Compression Load Cell

#### SPECIFICATIONS

- High Reliability Design for OEM, Appliance and Medical Applications
- 10 – 200 lbf Ranges
- Compact Coin Cell Package
- Anti-Rotation Mounting Features
- CE Compliance

The **FX19** units are intended for OEM use in laboratory, hospital or consumer product applications, establishing a breakthrough price/performance value for compression load cells. The FX19 is a 1% load cell device with full scale ranges of 10, 25, 50 or 100 and 200lbf compression. This new, low-cost technology enables force sensing in a whole new class of "smart" consumer and medical products.

MEAS' proprietary Microfused™ technology, derived from demanding aerospace applications, employs micro-machined piezoresistive strain gages fused with high temperature glass to a high performance stainless steel force measuring flexure. Microfused™ technology eliminates age-sensitive organic epoxies used in traditional load cell designs, providing excellent long term span and zero stability. Operating at very low strains, Microfused™ technology provides an essentially unlimited cycle life expectancy, superior resolution, high over-range capabilities and a ratiometric span of 20mV/V. The combination of stamped flexures and micro miniaturized MEMS strain gages permits low costs to be achieved in high volume OEM applications ranging from disposable medical devices to durable appliances and exercise equipment.

#### FEATURES

- Small
- Low Noise
- Robust: High Over-Range
- High Reliability
- mV Output: 20mV/V Nominal
- Low Deflection
- Fast
- Essentially Unlimited Cycle Life

#### APPLICATIONS

- Assembly Forces
- Physical Therapy Devices
- Patient Weight
- Hand Tool Forces
- Chiropractic and Exercise Equipment
- Consumables Monitoring: Copy Equipment and Vending systems
- Appliance Payload Monitoring: Washers, Dryers, Water Weight, Extraction Efficiency
- Appliance Unbalance Monitoring

## STANDARD RANGES

| Range     | lbf |
|-----------|-----|
| 0 to 0010 | •   |
| 0 to 0025 | •   |
| 0 to 0050 | •   |
| 0 to 0100 | •   |
| 0 to 0200 | •   |

## PERFORMANCE SPECIFICATIONS

Supply Voltage: 5.0V, Ambient Temperature: 25°C (unless otherwise specified)

| PARAMETERS                      | MIN   | TYP  | MAX  | UNITS      | NOTES               |
|---------------------------------|-------|------|------|------------|---------------------|
| Recommended Excitation          |       | 5    |      | V          |                     |
| Full Scale Output Span          | 16    | 20   | 24   | mV/V       |                     |
| Full Scale Output Span (200lbf) | 34.2  | 36   | 37.8 | mV/V       |                     |
| Zero Offset                     | -15   |      | 15   | mV/V       |                     |
| Non-Linearity                   | -1    |      | 1    | %Span      |                     |
| Hysteresis                      | -0.80 |      | 0.80 | %Span      |                     |
| Thermal Zero Shift              | -0.05 |      | 0.05 | %Span / °C |                     |
| Thermal Sensitivity Shift       | -0.05 |      | 0.05 | %Span / °C |                     |
| Insulation Resistance           | 50    |      |      | MΩ         | @500V <sub>DC</sub> |
| Maximum Overload                |       | 250  |      | %FS        |                     |
| Maximum Overload (200lbf)       |       | 150  |      | %FS        |                     |
| Operating Temperature           | 0     |      | 50   | °C         |                     |
| Storage Temperature             | -40   |      | +85  | °C         |                     |
| Creeping                        |       |      | 0.5  | %Span      | F.S. span in 3min   |
| Zero Drift                      |       |      | 0.5  | %Span      | Load F.S. 3min      |
| Zero Return                     | -0.8  |      | 0.8  | %Span      |                     |
| Span Repeat                     | -0.8  |      | 0.8  | %Span      |                     |
| Humidity                        | 0     |      | 90   | %R.H.      |                     |
| Deflection                      |       | 0.05 |      | mm         | At Rated Load       |
| Input Resistance                | 2.4   | 3    | 3.6  | kΩ         |                     |
| Output Resistance               | 1.76  | 2.2  | 2.64 | kΩ         |                     |

For custom configurations, consult factory.

### CE Compliance

IEC61000-4-2 [4 kV/ 4 kV (Air/Contact)]

IEC61000-4-3 (3 V/m)

IEC55022 Class A

## DIMENSIONS

### FX1900-0000

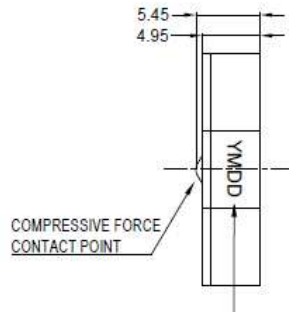
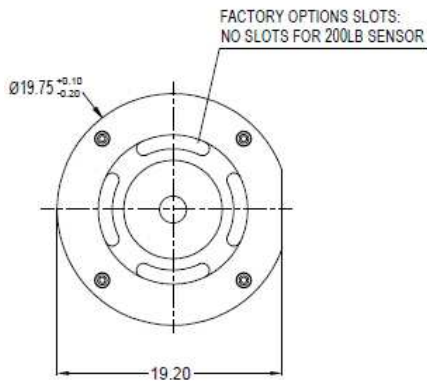

Y-YEAR(1-2011,2-2012,3-2013.....);  
M-MONTH(1-Jan,2-Feb.....A-Oct,B-Nov,C-Dec);  
DD-DATE.  
NOTED WITH OILINESS PEN.

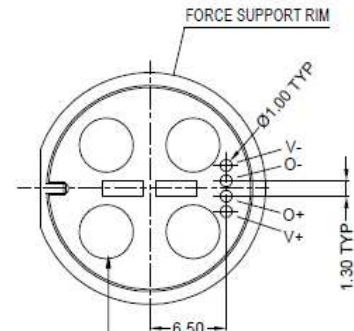

DELICATE SENSOR ELEMENTS INSIDE THE 4 BUMPS  
PROTRUDING 1.0MM MAX ABOVE RIM, DO NOT APPLY  
ANY FORCE.

### FX1900-XXX1

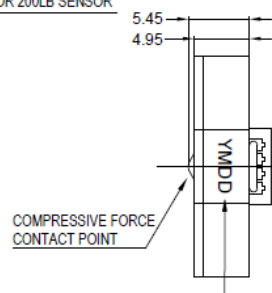
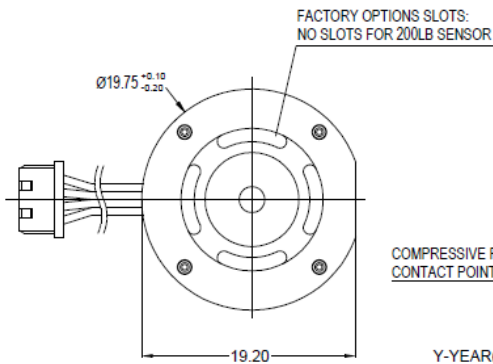

Y-YEAR(1-2011,2-2012,3-2013.....);  
M-MONTH(1-Jan,2-Feb.....A-Oct,B-Nov,C-Dec);  
DD-DATE.  
NOTED WITH OILINESS PEN.

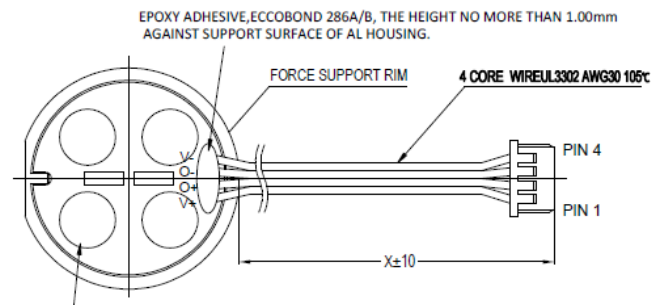

THE PUMP OF RUBBER SHOULD BE FREE FROM PRESS & SCRATCH.  
THE HIGHNESS NO MORE THAN 1.0mm AGAINST SUPPORT SURFACE  
OF AL HOUSING.

#### CONNECTOR INFORMATION:

| CONNECTOR | PART    | DESCRIPTION   | QTY | UN |
|-----------|---------|---|-----|----|
| MOLEX     | HOUSING | MOLEX: 51021-0400 4P FEMAL<br>PITCH: 1.25 NATRUAL                       | 1   | EA |
|           | TERIMAL | MOLEX CRIMP TERMINAL 50058-8000<br>MATE WITH 51021 (MX1.25) AWG 28#-32# | 4   | EA |

#### WIRE CONNECTION

|       |           |
|-------|-----------|
| PIN 1 | V+ RED    |
| PIN 2 | O+ YELLOW |
| PIN 3 | O- WHITE  |
| PIN 4 | V- BLACK  |

# FX1901-0001

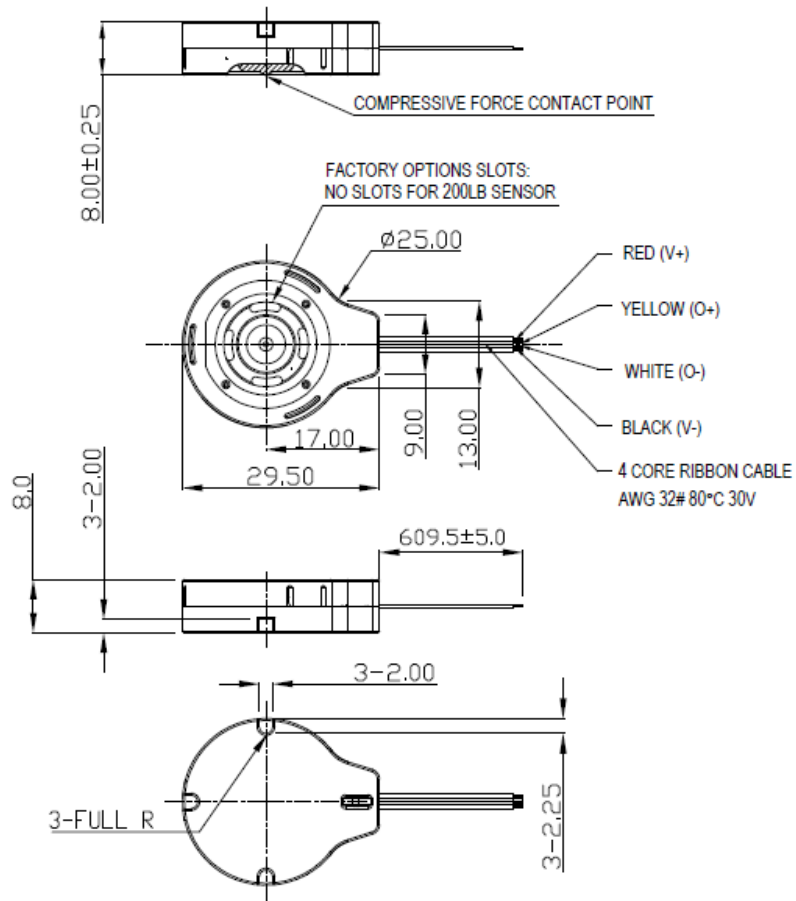

## WIRING INFORMATION

### FX1900-0000

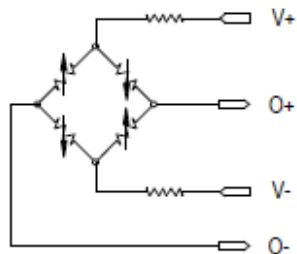

### FX1900-XXX1 FX1901-0001

