



DOG2 MEMS SERIES CAN J1939 INCLINOMETER

SPECIFICATIONS

- ◆ Dual axis inclinometer
- ◆ Measurement ranges $\pm 90^\circ$
- ◆ CAN J1939 interface

FEATURES

- ◆ 8 – 30 VDC supply voltage
- ◆ Digital signal processing includes
 - filter (e.g. vibration damping)
 - temperature compensation
- ◆ 12 bit resolution
- ◆ 100 Hz refresh rate
- ◆ $-40^\circ\text{C} - 85^\circ\text{C}$ temperature range
- ◆ Accuracy typically
 - 0.5° | $-40^\circ\text{C} - 85^\circ\text{C}$
 - 0.15° | 25°C

APPLICATIONS

- ◆ Mobile and stationary cranes
- ◆ Lift platforms
- ◆ Building control
- ◆ Weighing systems
- ◆ Truck chassis leveling
- ◆ Vehicle applications
- ◆ Road construction machines

The **DOG2 MEMS-Series inclinometer** dual axis is mainly developed with focus on platform leveling, dynamic engine management, tip-over protection and tilt alarm.

A fast response time and good accuracy makes this device the ideal choice for mobile leveling applications. It features digital signal processing including temperature compensation.

The integrated filter improves performance and allows using the sensor in many noisy environments (e.g. vibrations).

The inclinometer includes a powerful digital signal processing that offers various filter algorithms and allows customer specific OEM solutions. It is possible to adjust the sensor to different environments yielding an optimized performance. Customization can also be made in terms of angular range and connectivity, i.e. cable and connector.

The PA6.6 housing is very compact in size and has compression limiter bushings for safe installation of the sensor. It is compatible with oil, grease and fuel also. Therefore it is frequently used for engine and vehicle applications.

Dimensions [mm]

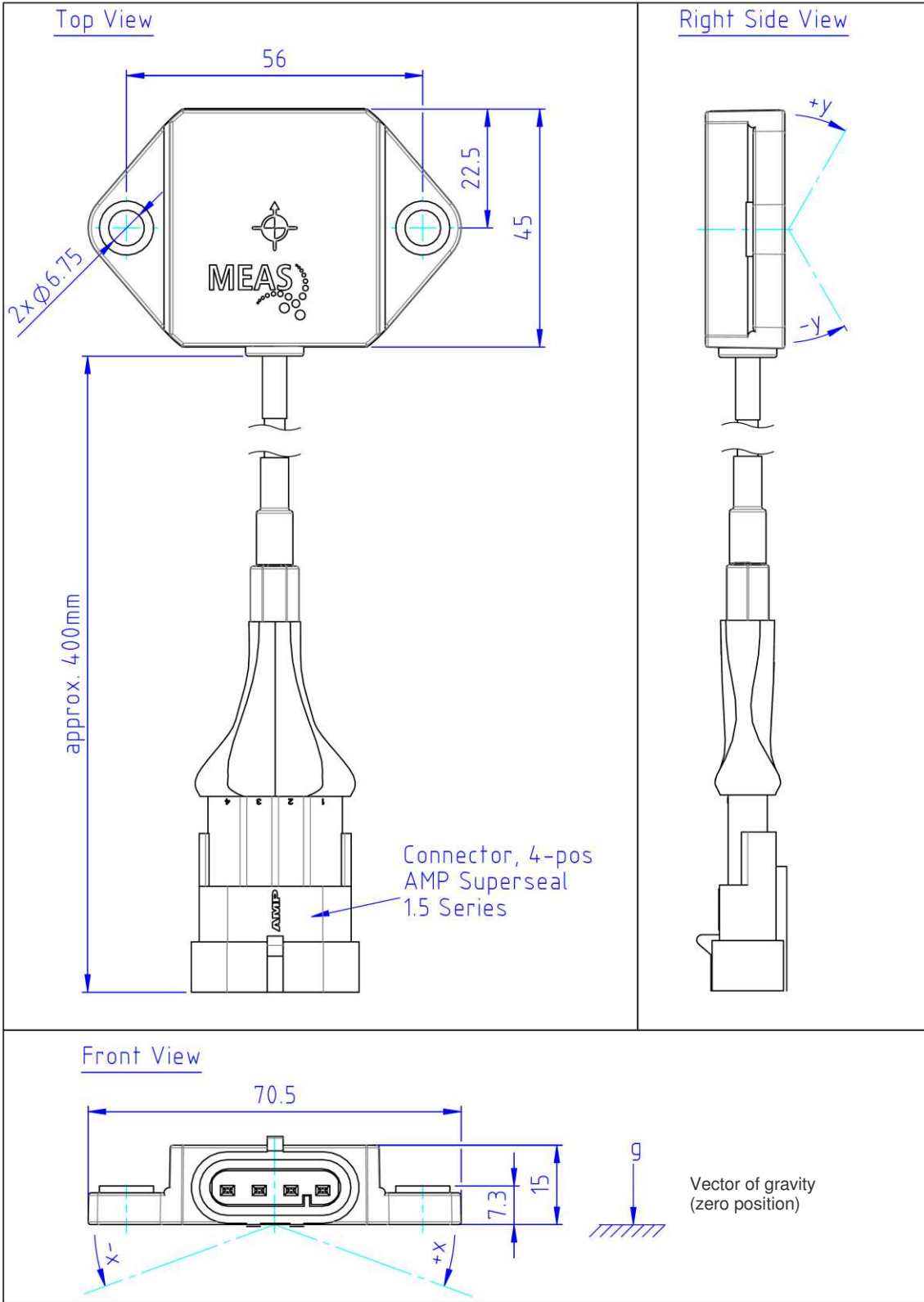

PARAMETERS

Parameter	Value	Comment
Range	±90°	Dual axis sensor
Accuracy, typ.	0.5°	T= -40 °C – 85 °C
Accuracy, typ.	0.15°	T= 25 °C
Resolution	0.01°	Limited by CAN protocol
Refresh rate	100 Hz	Internal processing
Startup time	<1 s	After power cycle
Supply/excitation voltage	8 – 30 V	Direct current (DC) stabilized
Supply current, typ.	<30 mA	Typ. 20mA, peak 30mA during transmit
Output	x-axis and y-axis	Linearized and temperature compensated angles in degree, reference is plane perpendicular to vector of gravity = earth surface
Interface	SAE J1939 CAN2.0B	250 kbps Source Address: - G-NSDOG2-200 : 0xC2 (fix) - G-NSDOG2-207 : 0xC0 (default); settable in the range of [0x80 – 0xF7]
Connector	AMP Superseal 1.5-Series, 4-pos. cap housing, TE Connectivity part-no. 282106-1	Requires 4-pos. plug housing, AMP Superseal 1.5-Series at connecting harness, TE Connectivity part-no. 282088-1
Cable	4 wire 0.25 mm ² , outer diameter Ø3.9 mm	PUR, length incl. connector 400 mm, full temperature range, flexible
Operation temperature range	-40 °C – 85 °C	
Storage temperature range	-40 °C – 85 °C	
Weight, typ.	60 g	
Dimensions	70.5 mm x 45 mm x 15 mm	W x D x H

CONNECTOR PINNING

Pin	Function	Description
1	V _{CC}	8 to 30 VDC supply input (+)
2	GND	GND
3	CAN H	CAN high line , in/out
4	CAN L	CAN low line , in/out

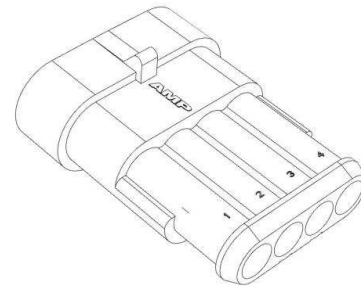

The CAN J1939 detailed description is included in the specification, which is available on request.