

G1VL20C

SIDACs / Uni-directional (G1V Series)

170V, 280A

Feature

- Uni-directional
- Miniaturized compared to a K1V series
- For pulse generation, DC power with switching operation
- A reliable product with a track record, developed for many applications
- Pb free terminal
- RoHS:Yes

OUTLINE

Package (House Name): 1F

Package (JEDEC Code): DO-214AC



Equivalent circuit

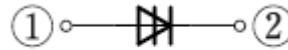

Absolute Maximum Ratings (unless otherwise specified : Tl=25°C)

Item	Symbol	Conditions	Ratings	Unit
Storage temperature	T _{stg}		-40 to 125	°C
Junction temperature	T _j		125	°C
Maximum off-state voltage	V _{DRM(A)}		170	V
RMS on-state current	I _T	Tl=98°C, 50Hz sine wave, θ=180°	1	A
Pulse on-state current	I _{TRM}	Ta=25°C, pulse width 10μs, 5Hz sine wave	280	A
Pulse on-state current	I _{TRM}	Ta=25°C, pulse width 10μs, 60Hz sine wave	120	A
Critical rate of rise of on-state current	di _T /dt		150	A/μs

* :See the original Specifications

Electrical Characteristics (unless otherwise specified : Tl=25°C)

Item	Symbol	Conditions	Ratings			Unit
			MIN	TYP	MAX	
Breakover voltage	$V_{BO(A)}$	Pulse measurement, $dv/dt=4V/ms$	190		210	V
Off-state current	$I_{DRM(A)}$	$V_D=170V$			10	μA
Breakover current	$I_{BO(A)}$	$V_{BO}-0.5V$			0.5	mA
Holding current	$I_{H(A)}$				60	mA
Holding current	$I_{H(K)}$				60	mA
On-state voltage	$V_{T(A)}$	$I_T=1A$			1.5	V
On-state voltage	$V_{T(K)}$	$I_T=1A$			1.5	V
Switching resistance	$R_{S(A)}$		0.1			k Ω
Thermal resistance	$R_{th(j-l)}$	Junction to lead			23	$^{\circ}C/W$

* :See the original Specifications

CHARACTERISTIC DIAGRAMS

オン電圧 - オン電流
On-state Voltage vs On-state Current

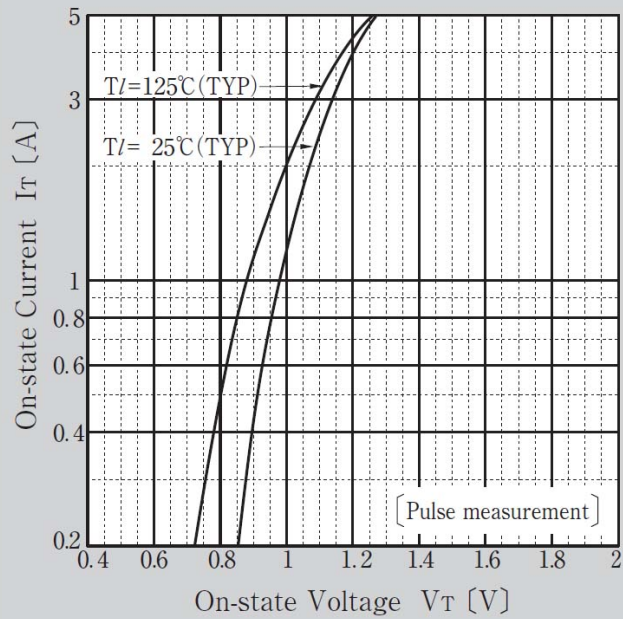

V_{BO} - T_j 特性
Breakover Voltage vs Junction Temperature

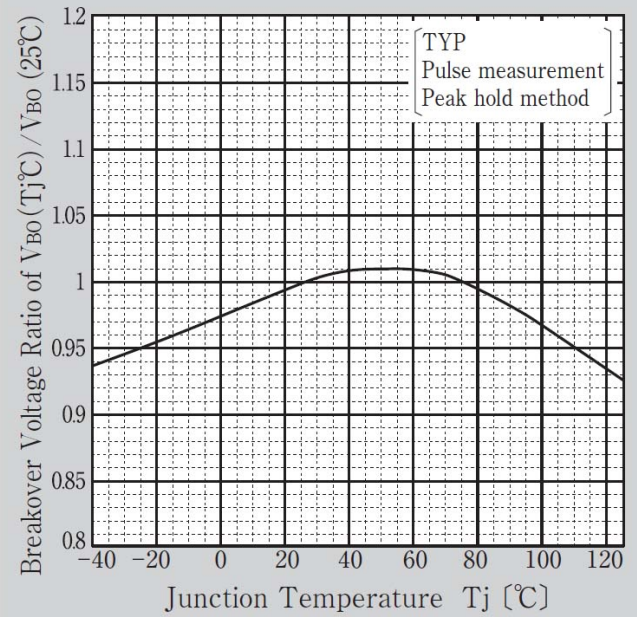

I_H - T_j 特性
Holding Current vs Junction Temperature

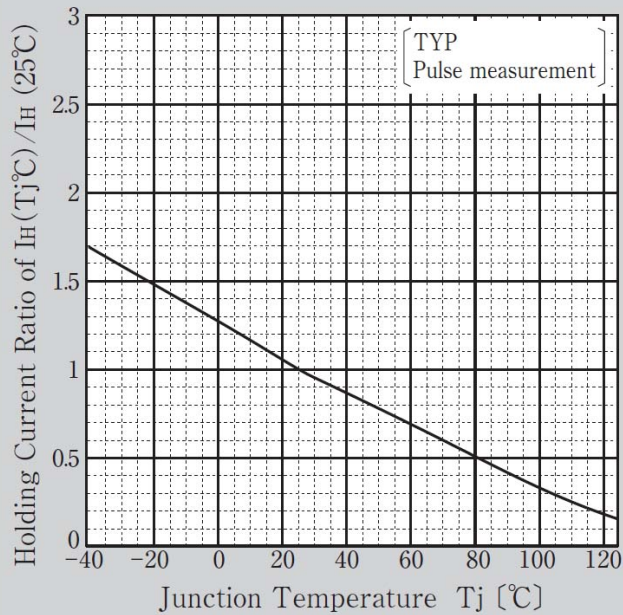

せん頭パルス電流
Pulse On-state Current Rating (I_{TRM})

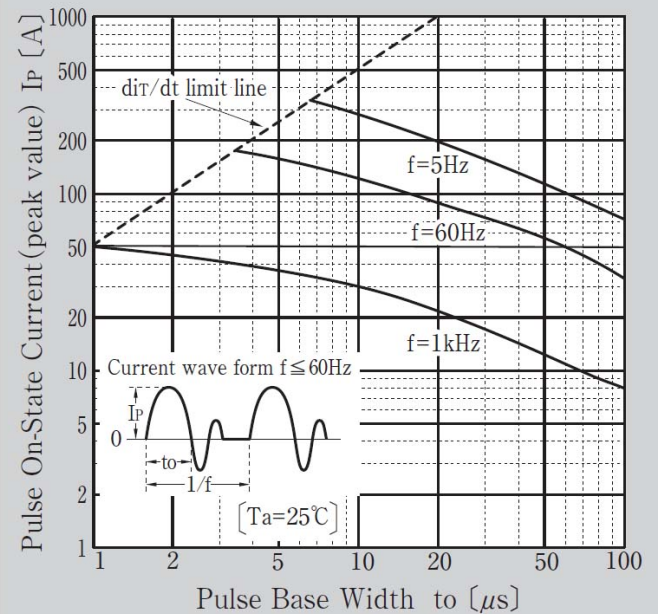

I_{TRM} デイレーティング

Pulse On-state Current Derating (I_{TRM})

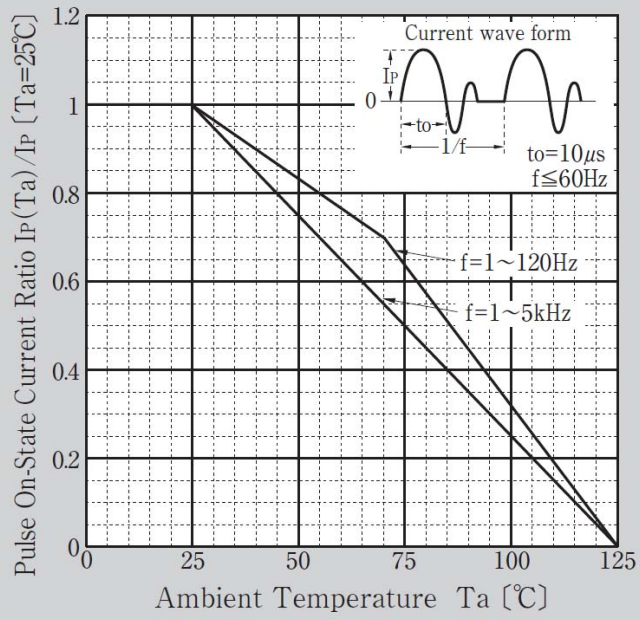

B3

JEDEC Code	DO-214AC
JEITA Code	-
House Name	1F, CF

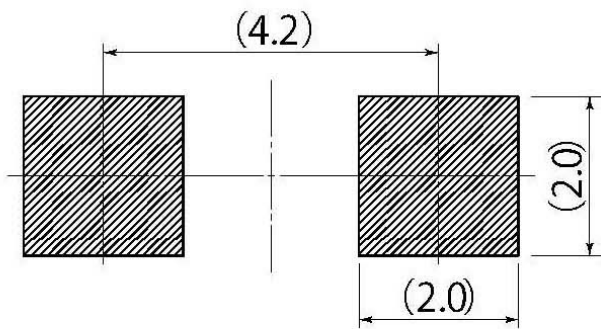
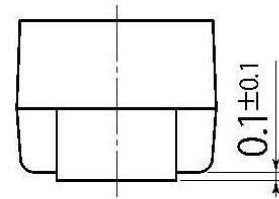
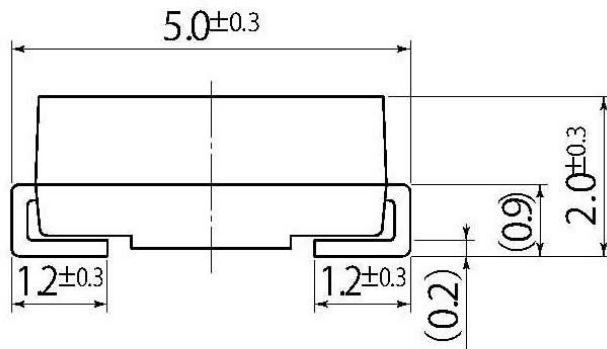
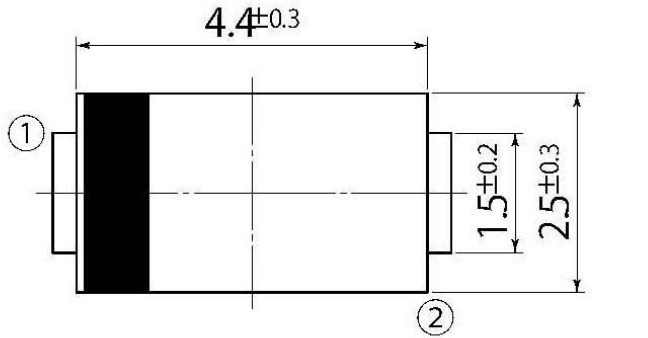

Referential Soldering Pad

• Optimize soldering pad to the board design and soldering condition.