

G1VL8C

SIDACs / Uni-directional (G1V Series)

70V, 80A

Feature

- Uni-directional
- Miniaturized compared to a K1V series
- For pulse generation, DC power with switching operation
- A reliable product with a track record, developed for many applications
- Pb free terminal
- RoHS:Yes

OUTLINE

Package (House Name): 1F

Package (JEDEC Code): DO-214AC



Equivalent circuit

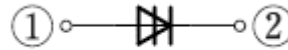

Absolute Maximum Ratings (unless otherwise specified : Tl=25°C)

Item	Symbol	Conditions	Ratings	Unit
Storage temperature	T _{stg}		-40 to 125	°C
Junction temperature	T _j		125	°C
Maximum off-state voltage	V _{DRM(A)}		70	V
RMS on-state current	I _T	Tl=98°C, 50Hz sine wave, θ=180°	1	A
Pulse on-state current	I _{TRM}	Ta=25°C, pulse width 10μs, 60Hz sine wave	80	A
Critical rate of rise of on-state current	di _T /dt		150	A/μs

* : See the original Specifications

Electrical Characteristics (unless otherwise specified : Tl=25°C)

Item	Symbol	Conditions	Ratings			Unit
			MIN	TYP	MAX	
Breakover voltage	$V_{BO(A)}$	Pulse measurement, $dv/dt=4V/ms$	75		90	V
Off-state current	$I_{DRM(A)}$	$V_D=70V$			10	μA
Breakover current	$I_{BO(A)}$				1	mA
Holding current	$I_{H(A)}$				100	mA
Holding current	$I_{H(K)}$				100	mA
On-state voltage	$V_{T(A)}$	$I_T=1A$			1.5	V
On-state voltage	$V_{T(K)}$	$I_T=1A$			1.5	V
Switching resistance	$R_{S(A)}$		0.1			$k\Omega$
Thermal resistance	$R_{th(j-l)}$	Junction to lead			23	$^{\circ}C/W$

※ :See the original Specifications

CHARACTERISTIC DIAGRAMS

On-state Voltage vs On-state Current

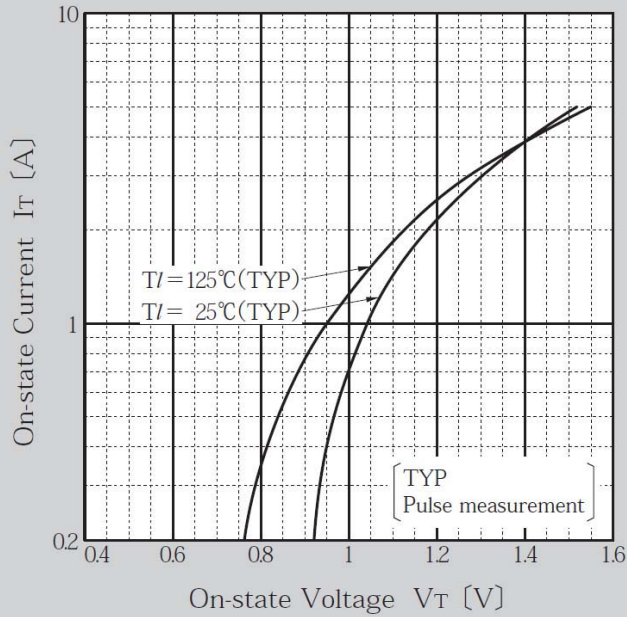

Breakover Voltage vs Junction Temperature

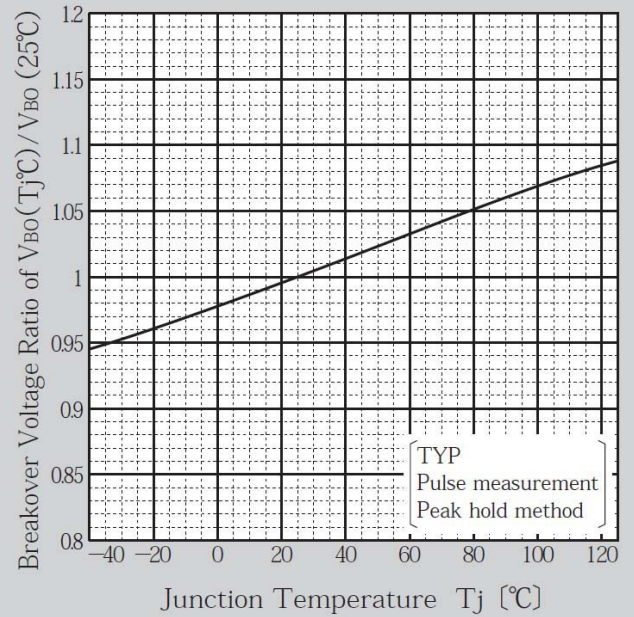

Holding Current vs Junction Temperature

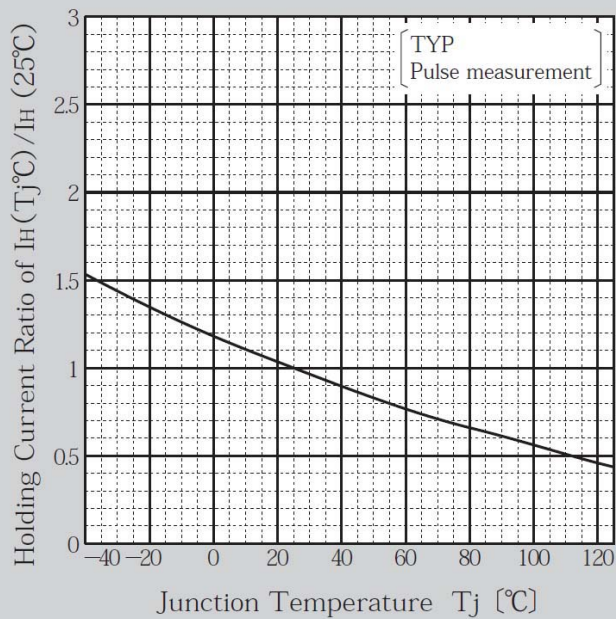

Pulse On-state Current Rating (I_{TRM})

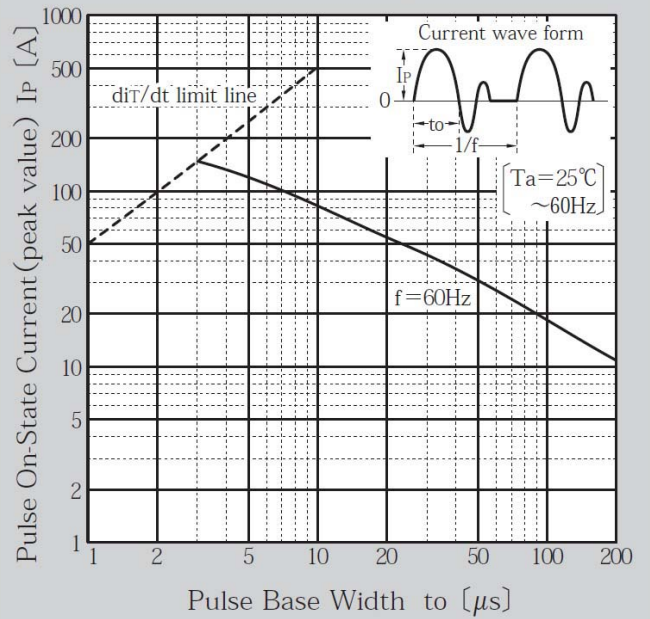

Pulse On-state Current Derating (ITRM)

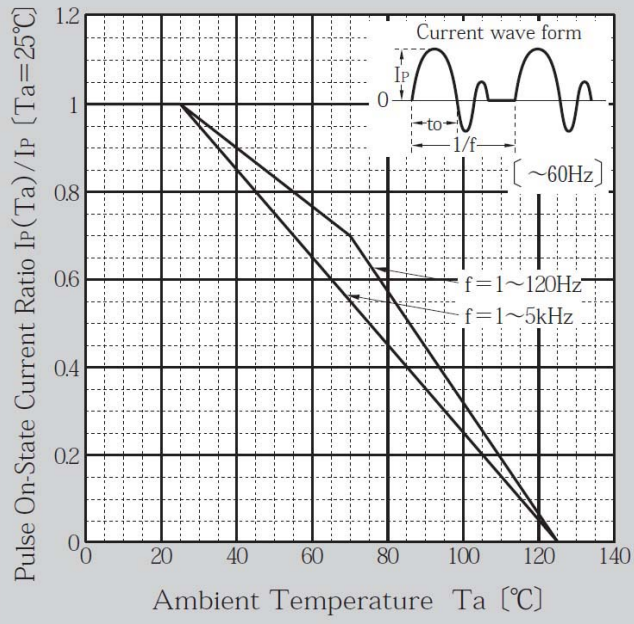

B3

JEDEC Code	DO-214AC
JEITA Code	-
House Name	1F, CF

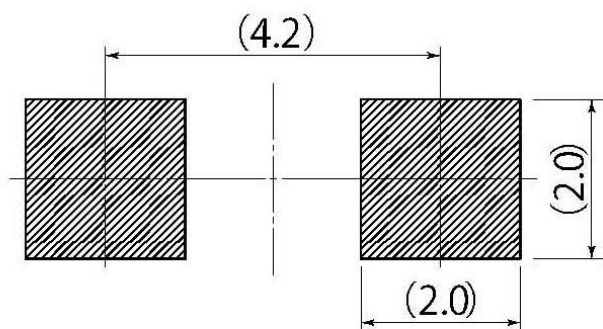
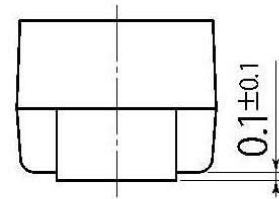
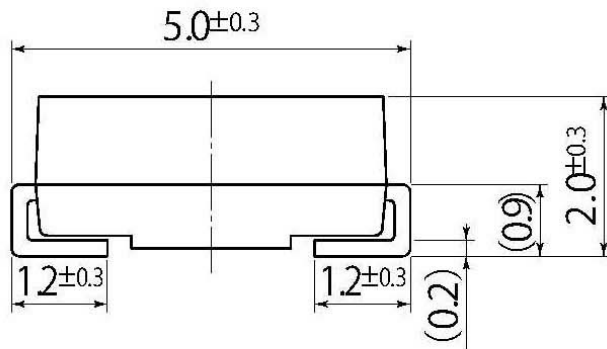
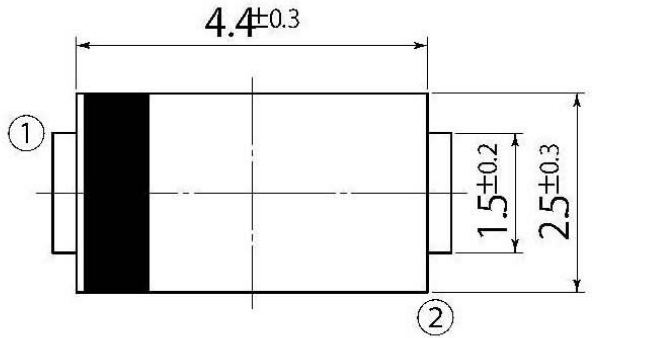

Referential Soldering Pad

• Optimize soldering pad to the board design and soldering condition.