



# TAOGLAS®



# Datasheet

## LTE Ultima II

**Part No:**  
G35.A.305111

### Description

Ultima II Super Low Profile LTE Permanent Mount

### Features:

- LTE Cellular
- Durable PC Enclosure
- Heavy Duty Permanent (Screw) Mount
- IP67 Rated Enclosure
- Diameter:57mm
- Height: 17.4mm (Not including thread)
- Cable: 3000mm TGC-200
- Connector: SMA(M)
- RoHS & Reach Compliant

<b>1.</b>	<b>Introduction</b>	<b>2</b>
<b>2.</b>	<b>Specification</b>	<b>3</b>
<b>3.</b>	<b>Antenna Characteristics</b>	<b>4</b>
<b>4.</b>	<b>Radiation Patterns</b>	<b>9</b>
<b>5.</b>	<b>Mechanical Drawing</b>	<b>18</b>
<b>6.</b>	<b>Packaging</b>	<b>19</b>
<hr/>		
	Changelog	20

Taoglas makes no warranties based on the accuracy or completeness of the contents of this document and reserves the right to make changes to specifications and product descriptions at any time without notice. Taoglas reserves all rights to this document and the information contained herein. Reproduction, use or disclosure to third parties without express permission is strictly prohibited.



# 1. Introduction



The G35 Ultima II is a high-performance permanent mount wideband cellular for external use on vehicles and assets worldwide. With diameter of 57mm and at only 17.4mm in height it is one of the lowest profile LTE antennas on the market.

Taoglas strive to continuously improve and expand our product portfolio in terms of both performance and design. With this in mind, the Ultima II is an upgrade on the original form factor, designed with a profile of just 17mm- 3mm lower than the first-generation Ultima, making it one of the lowest profile external LTE antenna solutions on the market. The mounting thread size has decreased from M24 to M14 making it much easier to install. The internal antenna has also been redesigned and see great improvements in efficiency in comparison to the original Ultima design.

Typical Applications Include:

- Smart Lighting
- Smart Cities
- Connected Enterprise
- Digital Signage

The IP67 rated enclosure is made from durable UV resistant PC making it extremely light, economical for shipping and with a minimum weight impact on vehicles. This also makes it ideal for use in humid environments such as water pits or marine applications as there are no external metal parts that may corrode. The closed cell foam with double-sided adhesive provides a permanent waterproof seal and can adjust to different curvatures, stopping water from leaking under the antenna into the mounting hole. Cables and Connectors are customizable, contact your regional Taoglas sales office for support or installation instructions. Note: The G35 is not suitable for mounting on a metal enclosure where the cables below will be enclosed in a metal box.

## 2. Specification

LTE Electrical								
Band	Frequency (MHz)	Efficiency (%)	Average Gain (dB)	Peak Gain (dBi)	Impedance	Polarization	Radiation Pattern	Max. input power
<b>5G NR/4G</b> Band 71	617-698	38.9	-4.10	2.03	50 Ω	Linear	Omni	2W
<b>4G/3G</b> Band 12,13,14,17,28,29	698-806	49.9	-3.02	4.25				
<b>4G/3G/NB-IoT/Cat M</b> Band 5,8,18,19,20,26,27	824-960	34.9	-4.57	3.25				
<b>5G NR/4G</b> Band 21,32,74,75,76	1427-1518	28.7	-5.42	2.08				
<b>4G/3G</b> Band 1,2,3,4,9,23,25,35,39,66	1710-2200	40.4	-3.94	3.55				
<b>4G/3G</b> Band 7,30,38,40,41	2300-2690	24.6	-6.09	2.90				
<b>5G NR/4G</b> Band 22,42,48,77,78,79	3300-5000	27.2	-5.66	5.88				
<b>LTE5200/Wi-Fi5800</b>	5150-5925	8.2	-10.87	-1.91				

Mechanical	
Dimensions	57.01mm x 17.4 mm
Weight	143g
Housing Material	PC
Connector	SMA(M)
Cable	3000mm TGC-200

Environmental	
Waterproof Rating	IP67
Operation Temperature	-40°C to 85°C
Relative Humidity	Non-condensing 65°C 95% RH

5G/4G Bands			
Band Number	5G NR / FR1 / LTE / LTE-Advanced / WCDMA / HSPA / HSPA+ / TD-SCDMA		
	Uplink	Downlink	Covered
B1	1920 to 1980	2110 to 2170	✓
B2	1850 to 1910	1930 to 1990	✓
B3	1710 to 1785	1805 to 1880	✓
B4	1710 to 1755	2110 to 2155	✓
B5	824 to 849	869 to 894	✓
B7	2500 to 2570	2620 to 2690	✗
B8	880 to 915	925 to 960	✗
B9*	1749.9 to 1784.9	1844.9 to 1879.9	✓
B11	1427.9 to 1447.9	1475.9 to 1495.9	✓
B12	699 to 716	729 to 746	✓
B13	777 to 787	746 to 756	✓
B14	788 to 798	758 to 768	✓
B17	704 to 716	734 to 746	✓
B18	815 to 830	860 to 875	✓
B19	830 to 845	875 to 890	✓
B20	832 to 862	791 to 821	✓
B21	1447.9 to 1462.9	1495.9 to 1510.9	✓
B22*	3410 to 3490	3510 to 3590	✓
B23*	2000 to 2020	2180 to 2200	✓
B24	1626.5 to 1660.5	1525 to 1559	✓
B25	1850 to 1915	1930 to 1995	✓
B26	814 to 849	859 to 894	✓
B27*	807 to 824	852 to 869	✓
B28	703 to 748	758 to 803	✓
B29		717 to 728	✓
B30	2305 to 2315	2350 to 2360	✓
B31	452.5 to 457.5	462.5 to 467.5	✓
B32		1452 to 1496	✓
B34		2010 to 2025	✓
B35		1850 to 1910	✓
B36		1930 to 1990	✓
B37		1910 to 1930	✓
B38		2570 to 2620	✗
B39		1880 to 1920	✓
B40		2300 to 2400	✓
B41		2496 to 2690	✗
B42		3400 to 3600	✓
B43		3600 to 3800	✓
B45		1447 to 1467	✓
B46		5150 to 5925	✗
B47		5855 to 5925	✗
B48		3550 to 3700	✓
B49		3550 to 3700	✓
B50		1432 to 1517	✓
B51		1427 to 1432	✓
B52		3300 to 3400	✗
B53		2483.5 to 2495	✓
B65	1920 to 2010	2110 to 2200	✓
B66	1710 to 1780	2110 to 2200	✓
B68	698 to 728	753 to 783	✓
B69		2570 to 2620	✗
B70	1695 to 1710	1995 to 2020	✓
B71	663 to 698	617 to 652	✓
B72	451 to 456	461 to 466	✓
B73	450 to 455	460 to 465	✓
B74	1427 to 1470	1475 to 1518	✓
B75		1432 to 1517	✓
B76		1427 to 1432	✓
B77		3300 to 4200	✓
B78		3300 to 3800	✓
B79		4400 to 5000	✓
B85	698 to 716	728 to 746	✓
B87	410 to 415	420 to 425	✗
B88	412 to 417	422 to 427	✗

### 3. Antenna Characteristics

#### 3.1 Test Setup

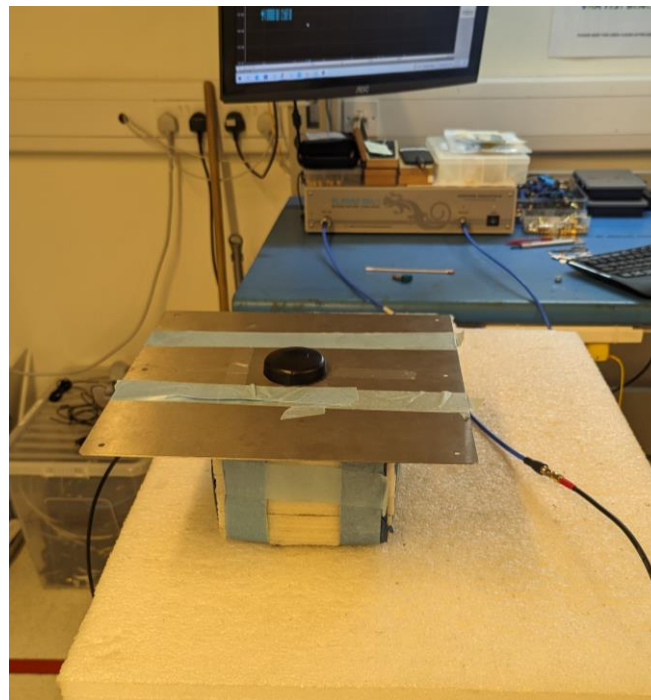
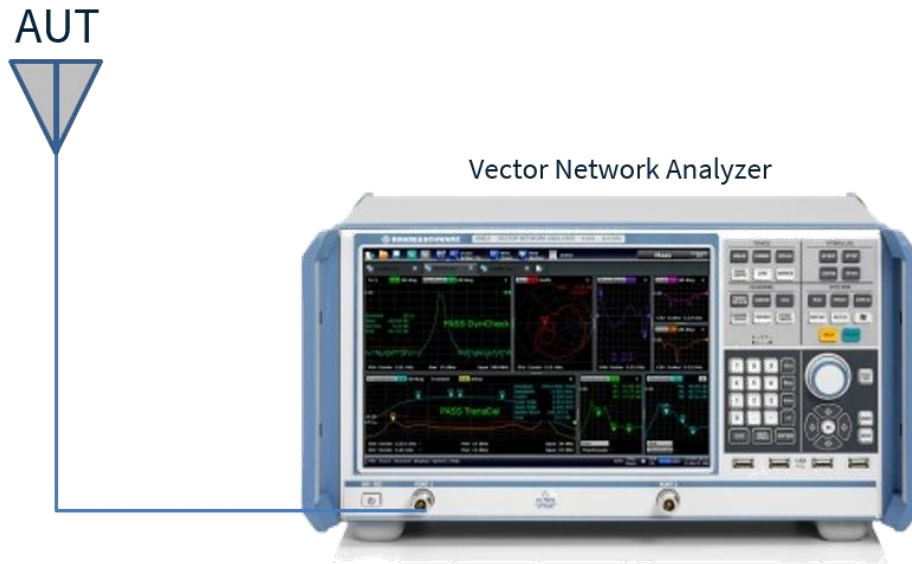

On 30cm x 30cm Ground Plane

### 3.2 Return Loss

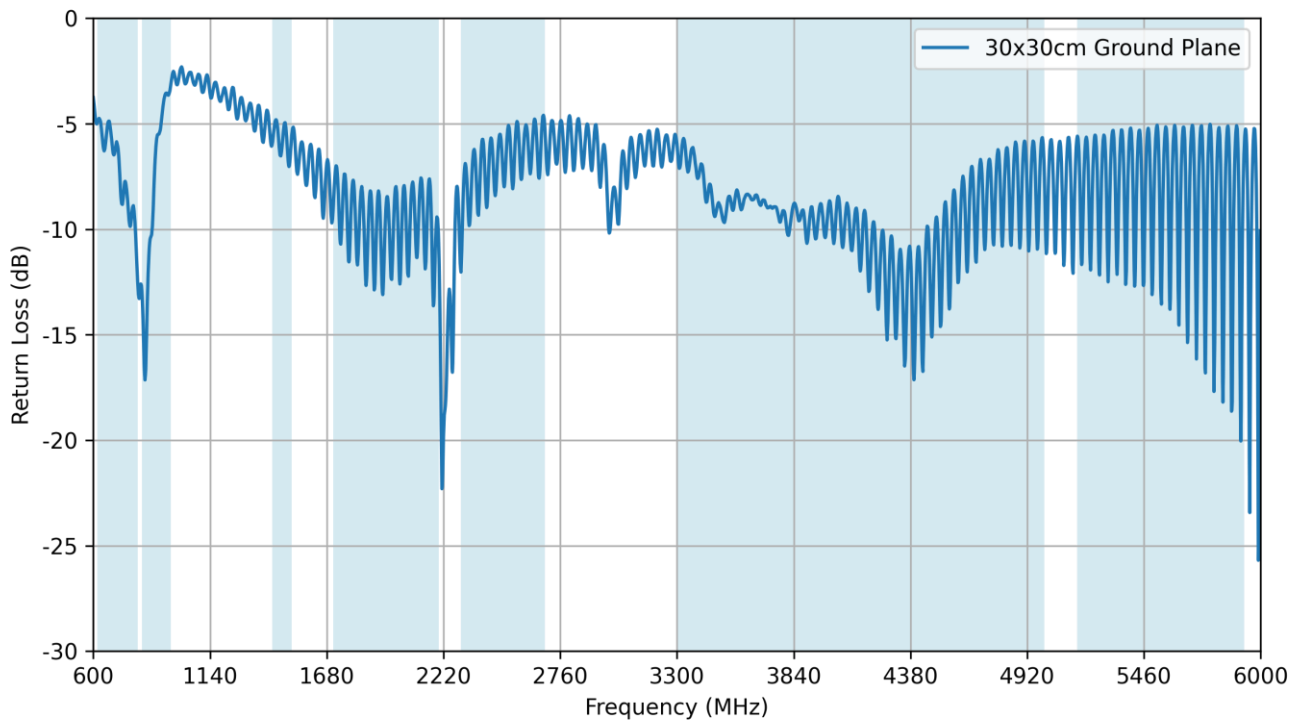

### 3.3 VSWR

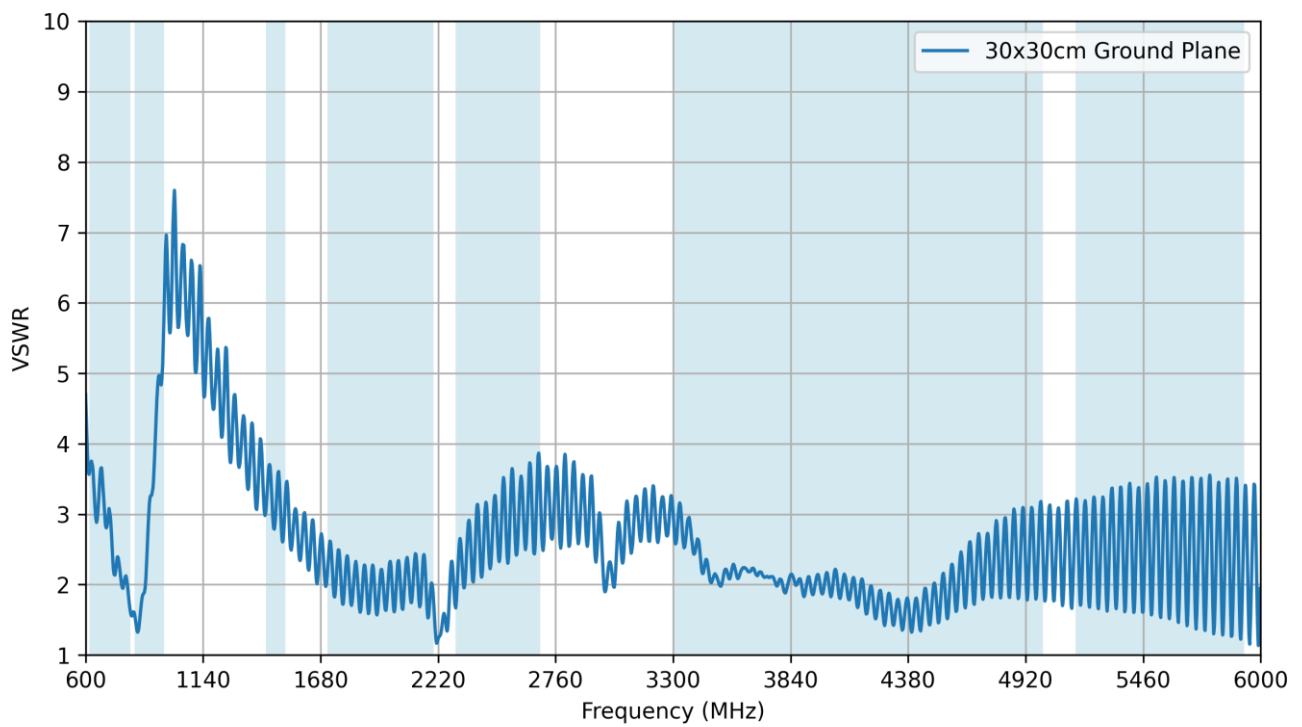

### 3.4 Efficiency

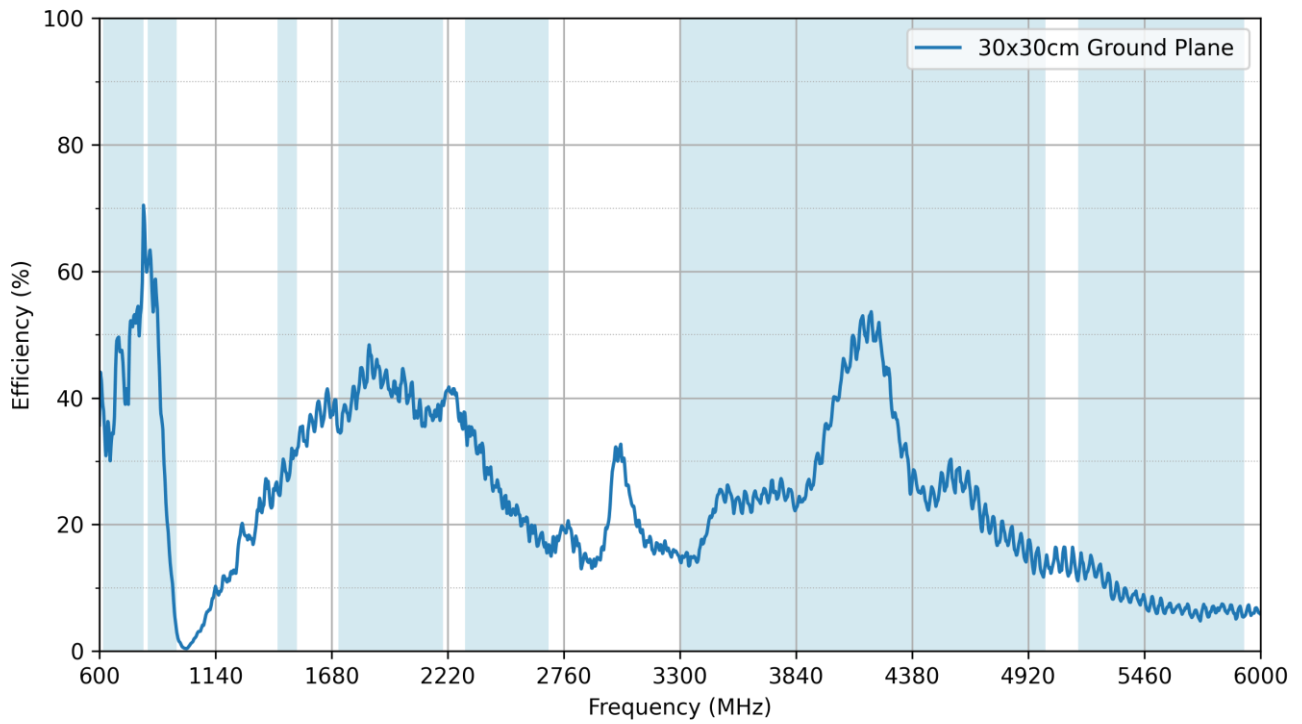

### 3.5 Average Gain

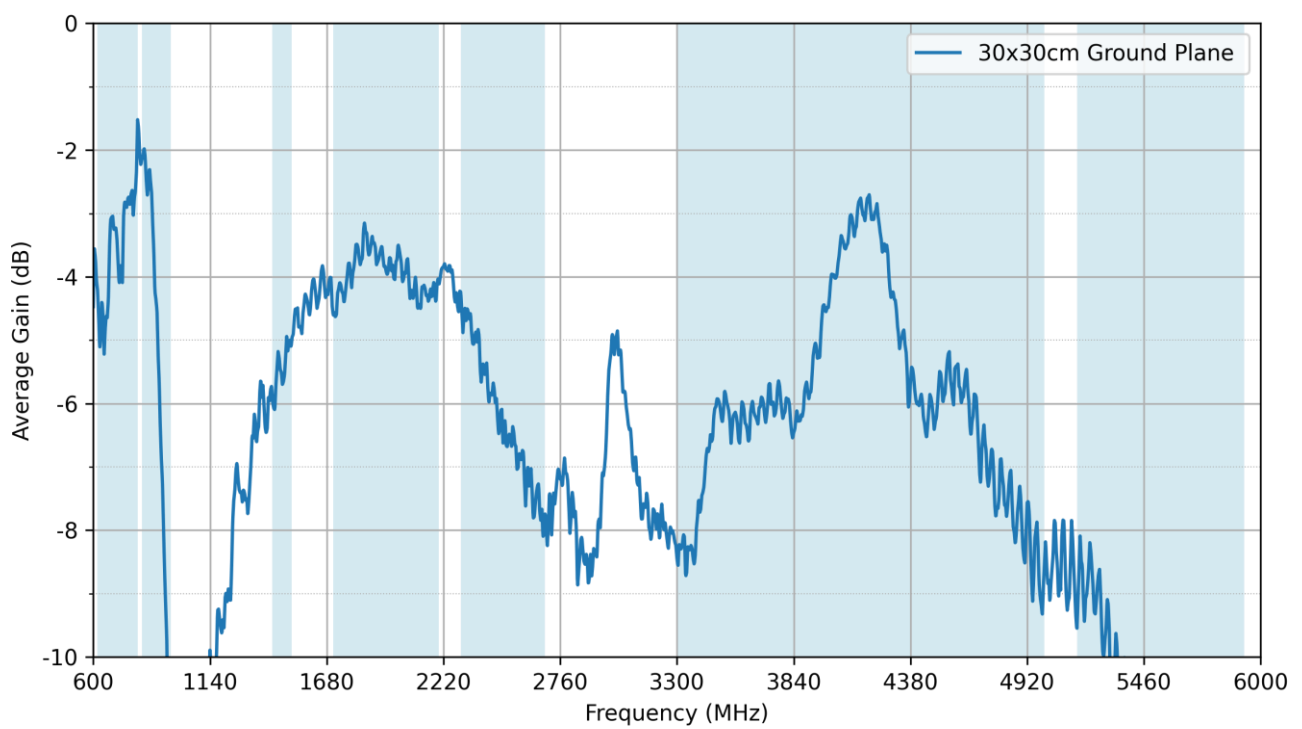



3.6 Peak Gain

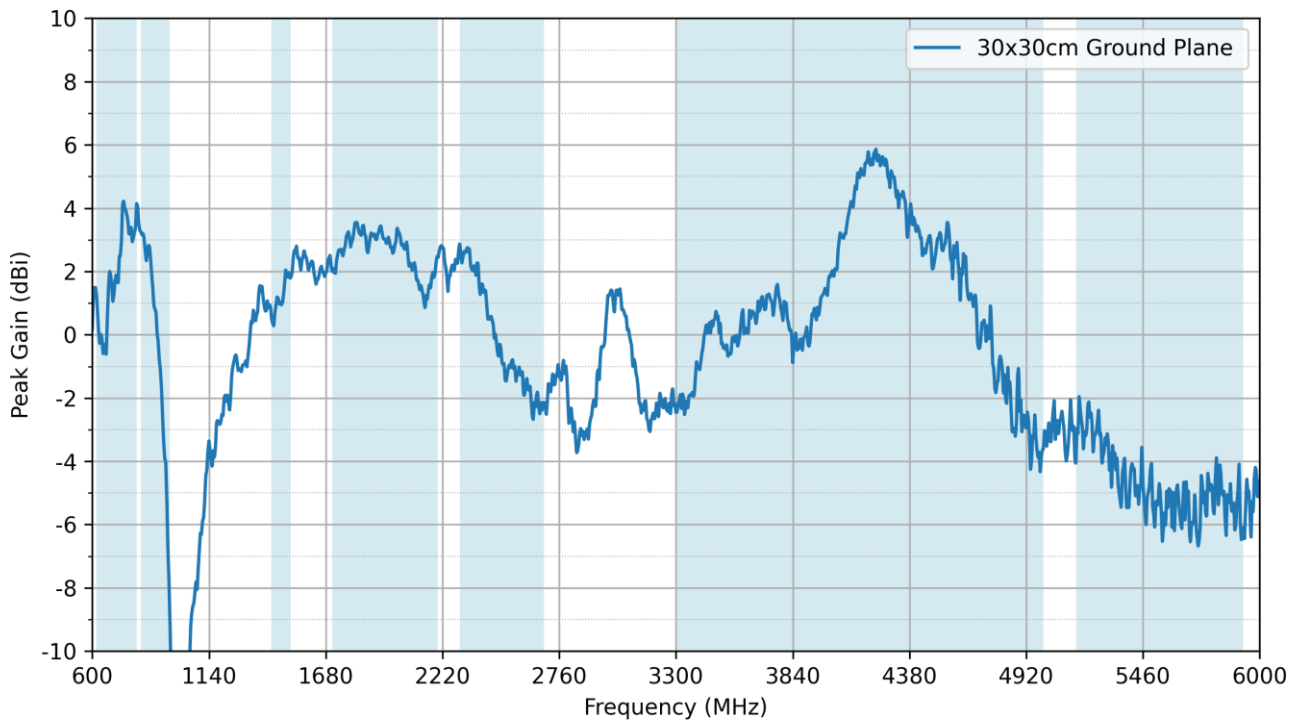

## 4. Radiation Patterns

### 4.1 Test Setup

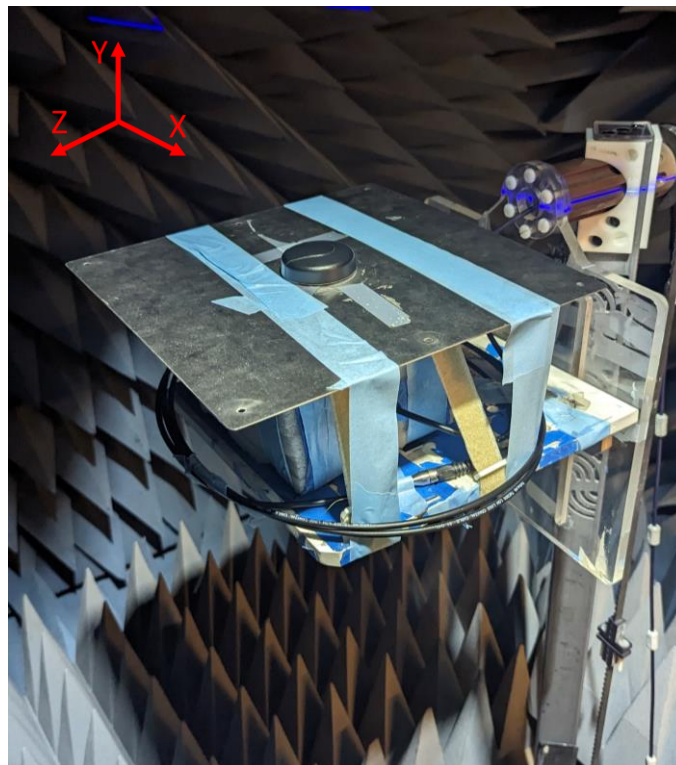
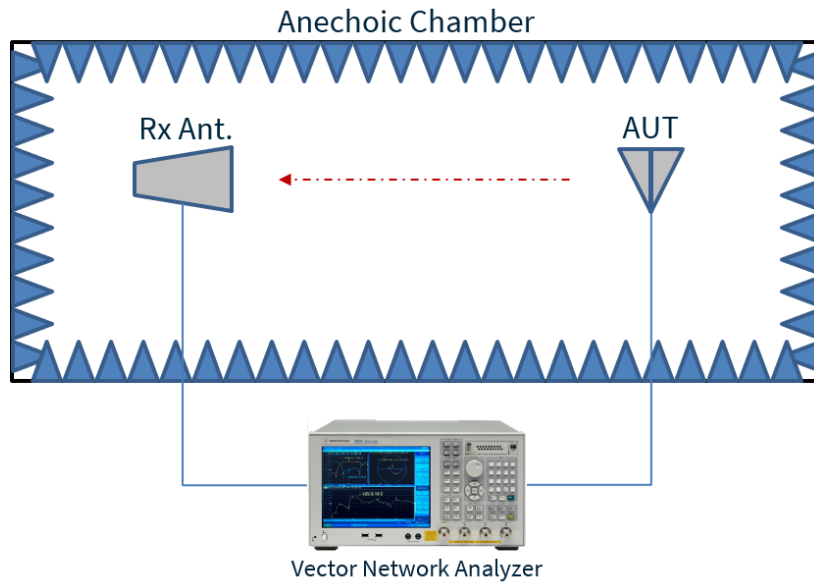

On 30cm x 30cm Ground Plane

4.2 30x30cm Ground Plane - Patterns at 650 MHz

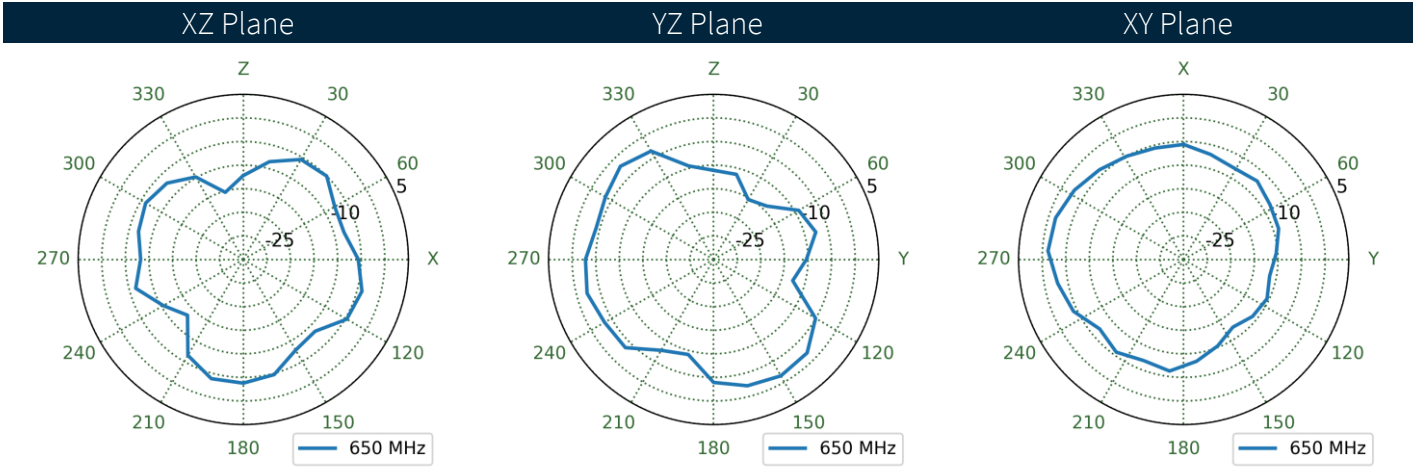
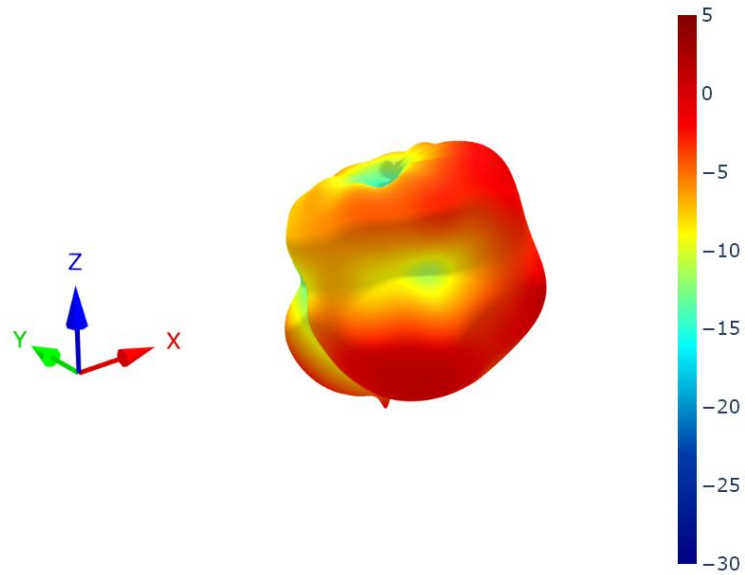

4.3 30x30cm Ground Plane - Patterns at 750 MHz

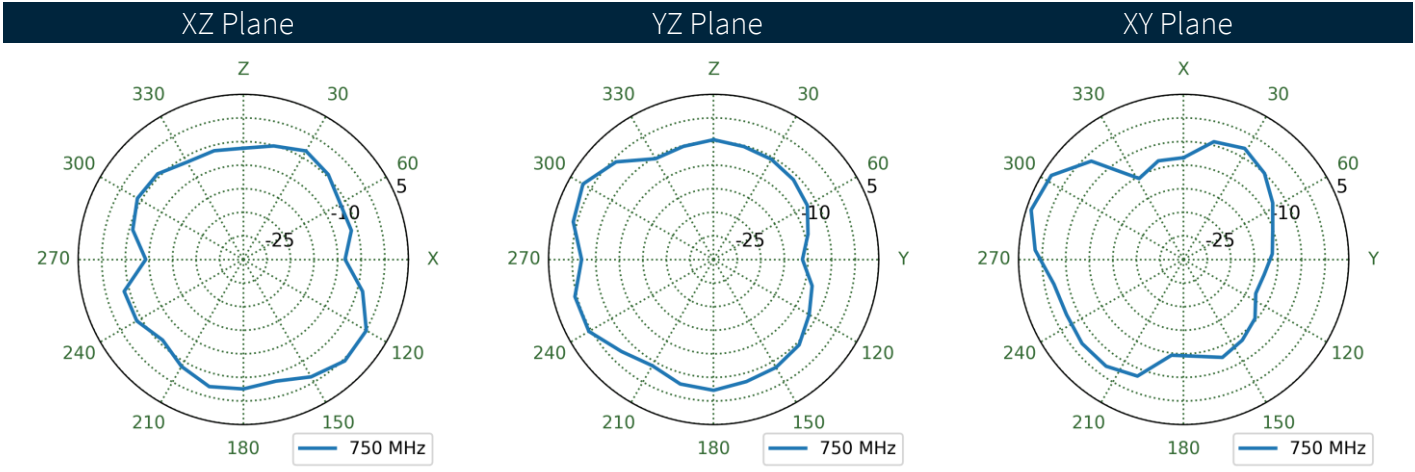
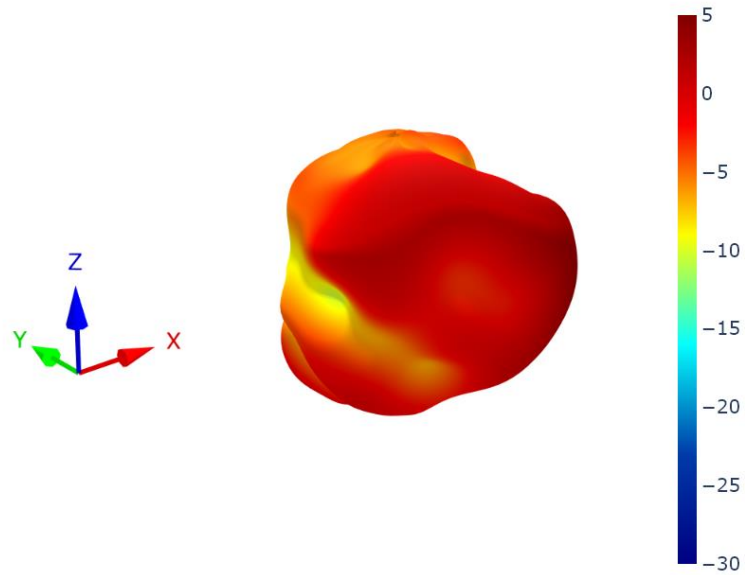

4.4 30x30cm Ground Plane - Patterns at 890 MHz

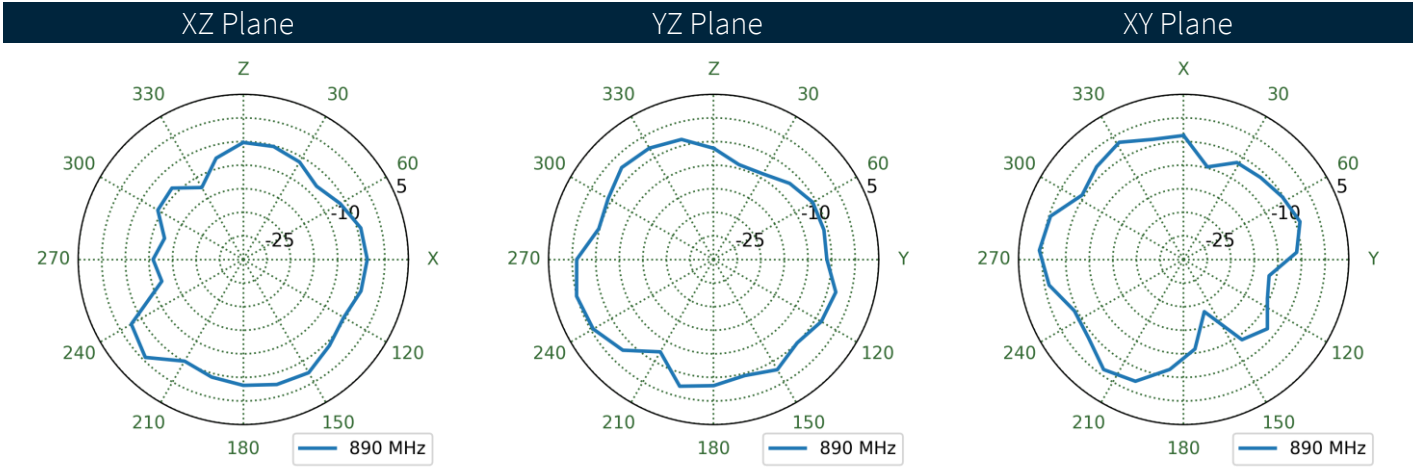
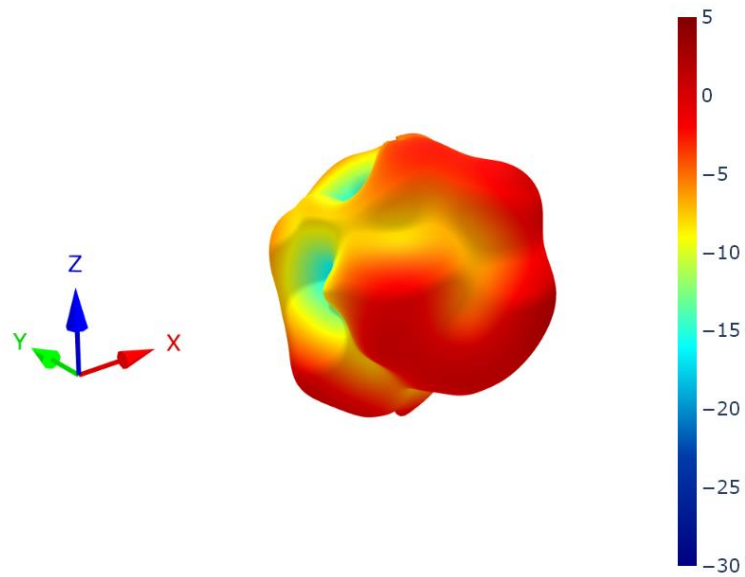

4.5 30x30cm Ground Plane - Patterns at 1475 MHz

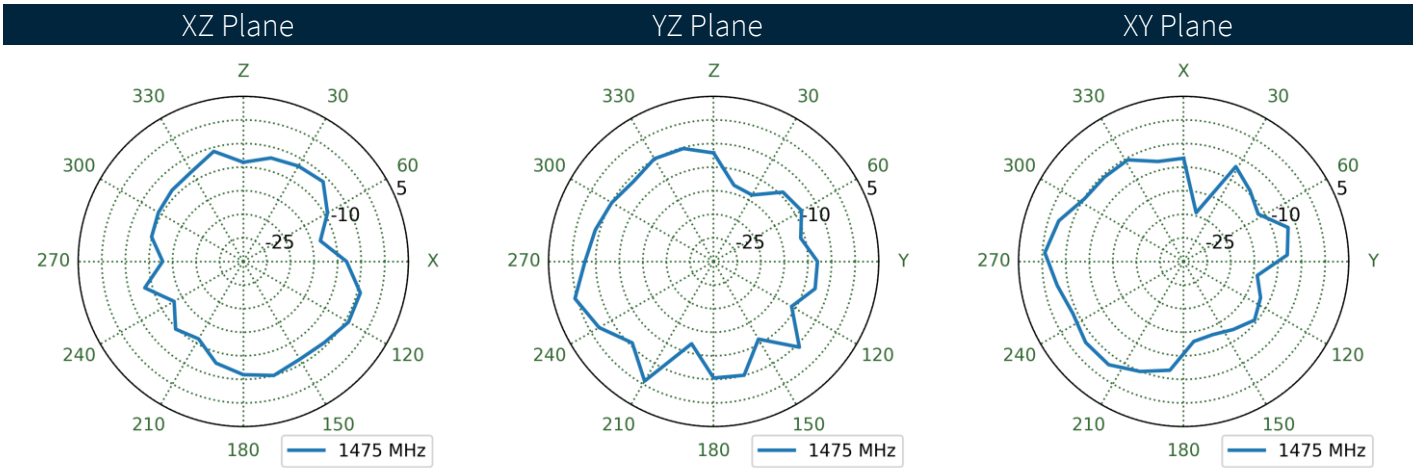
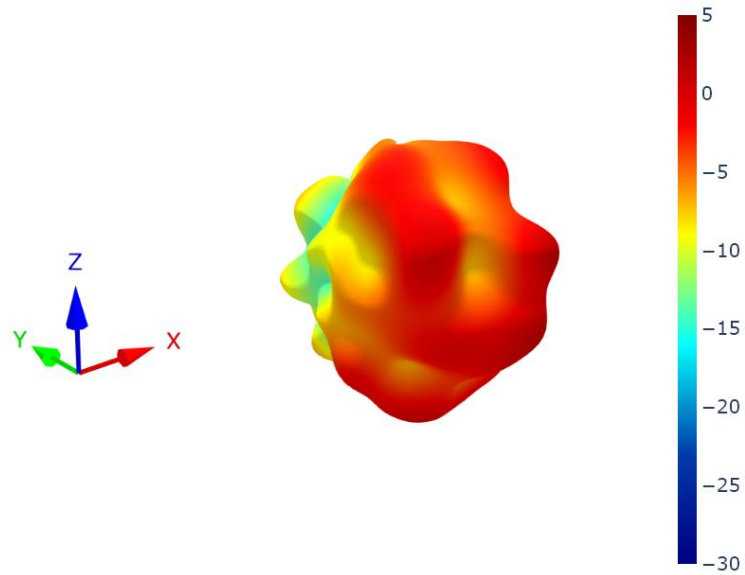

4.6 30x30cm Ground Plane - Patterns at 1950 MHz

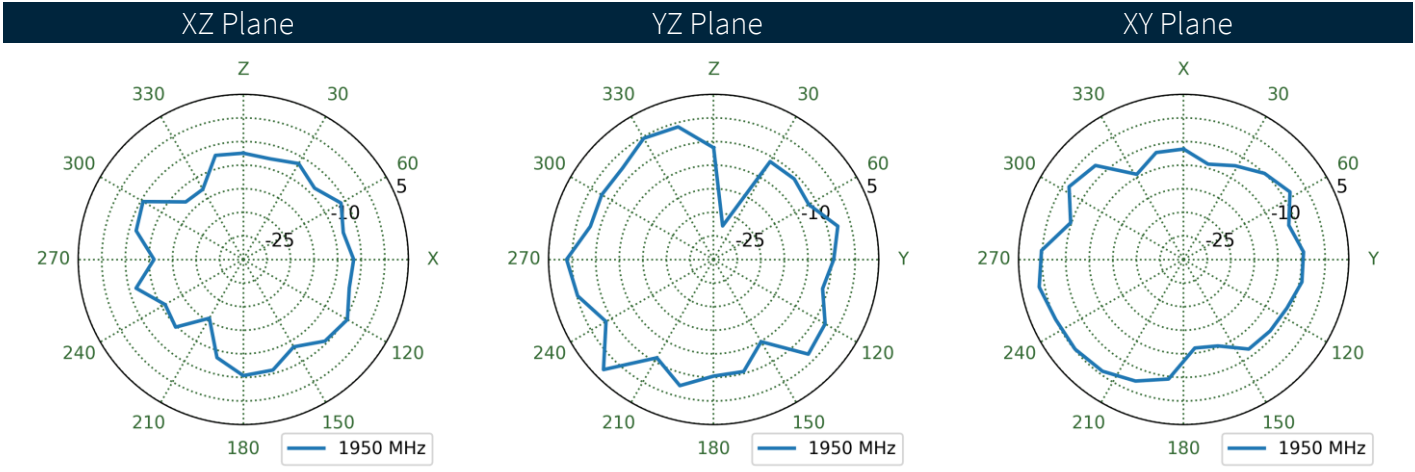
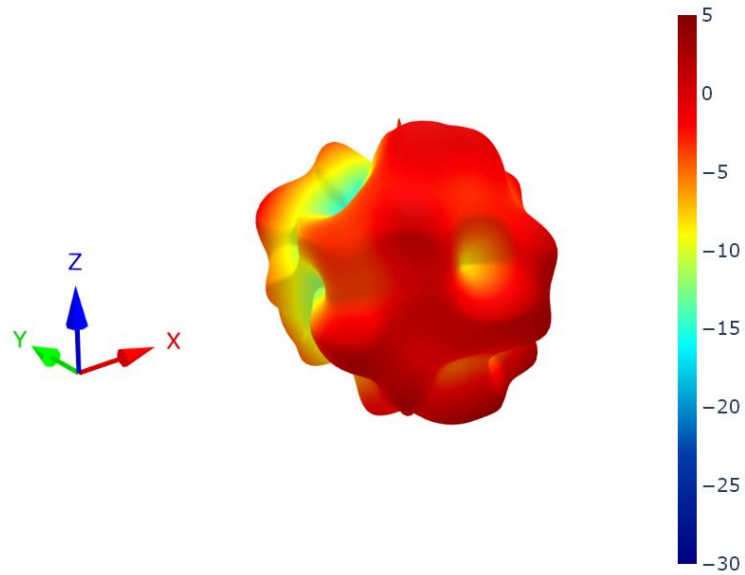

4.7 30x30cm Ground Plane - Patterns at 2490 MHz

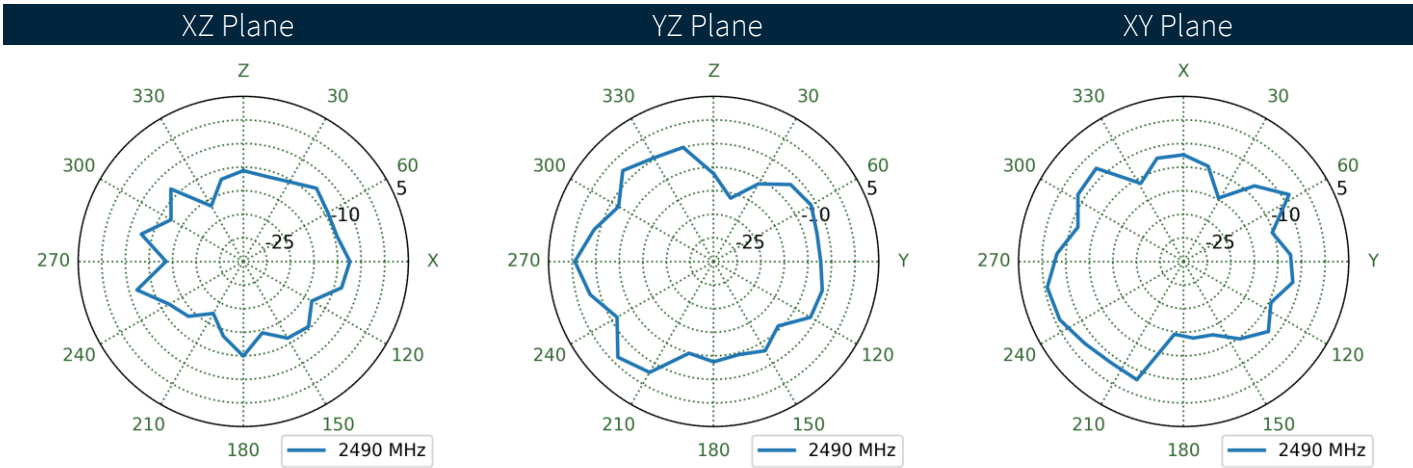
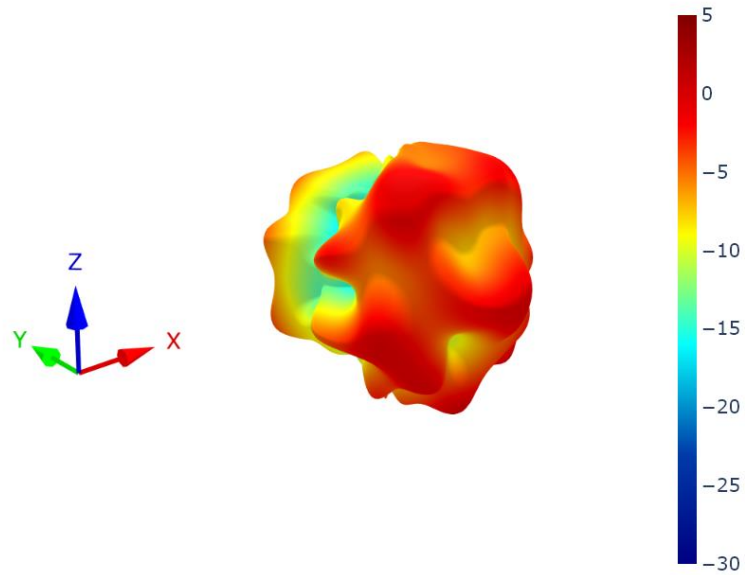



4.8 30x30cm Ground Plane - Patterns at 4150 MHz

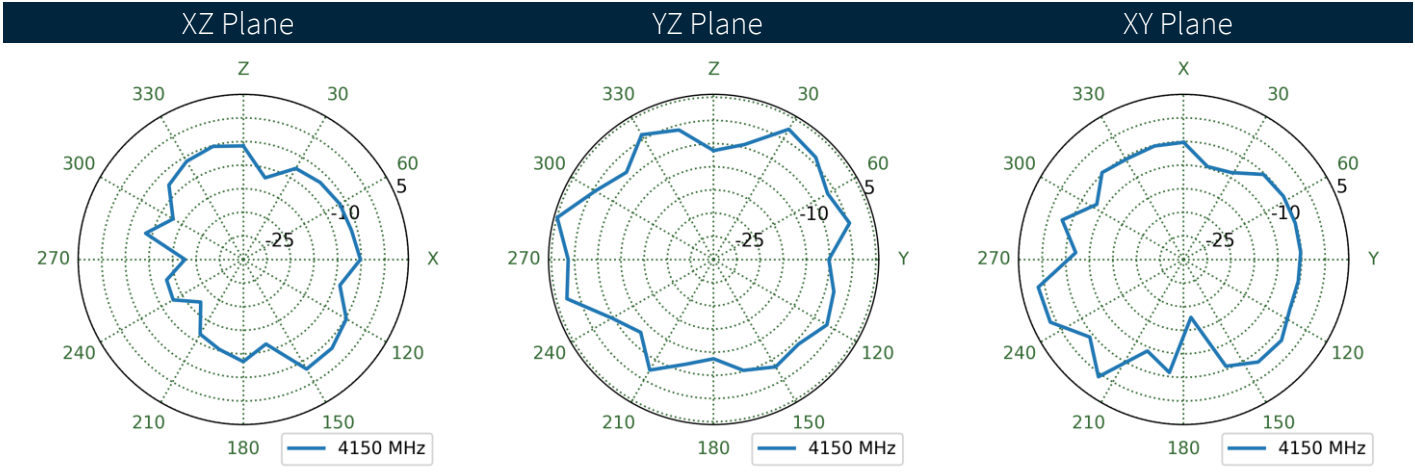
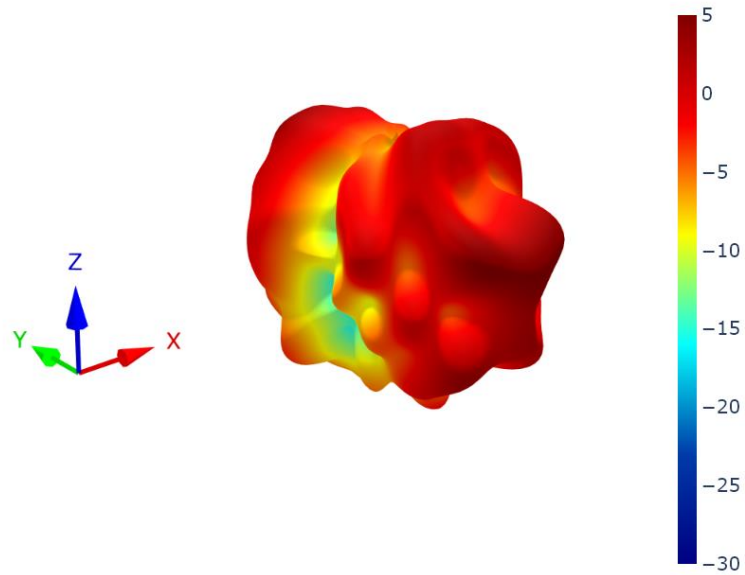

4.9 30x30cm Ground Plane - Patterns at 5550 MHz

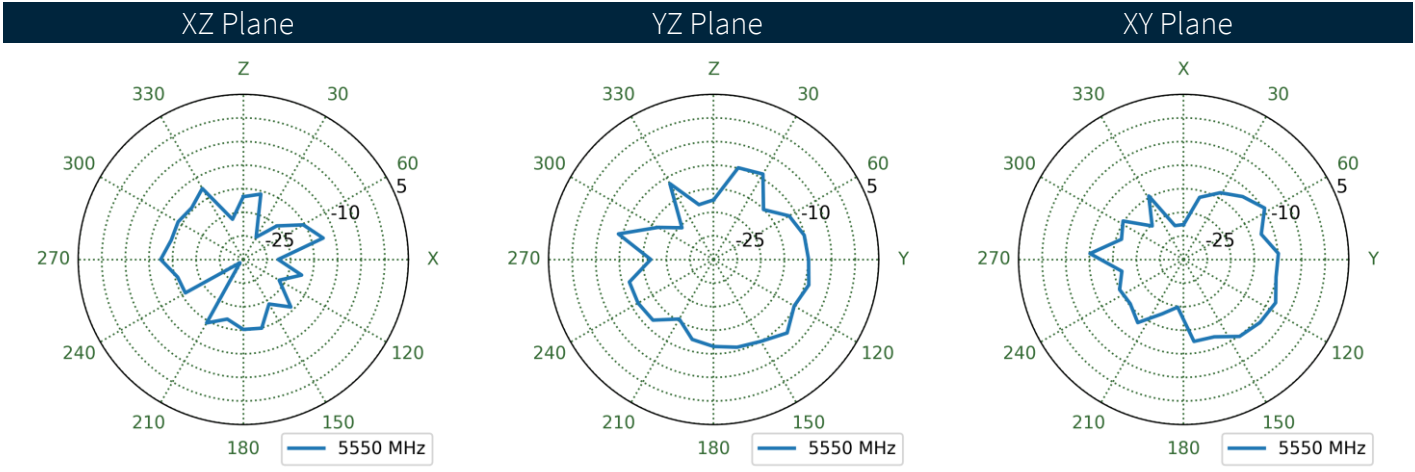
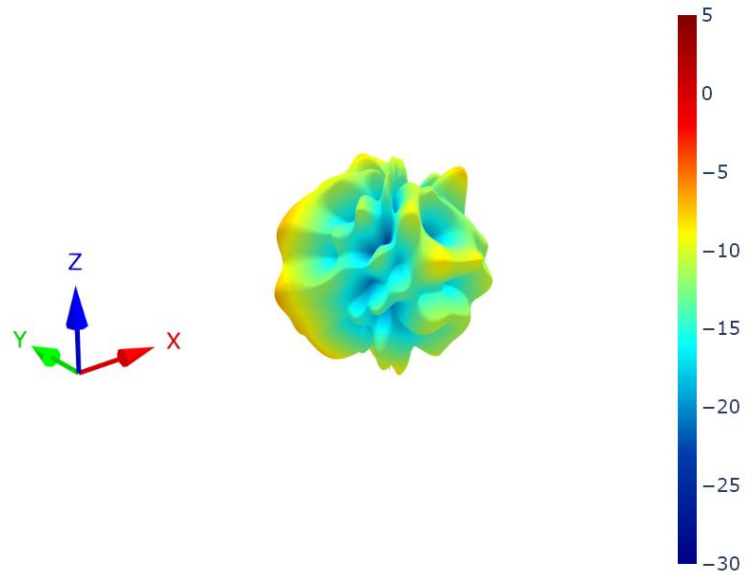

# 5. Mechanical Drawing

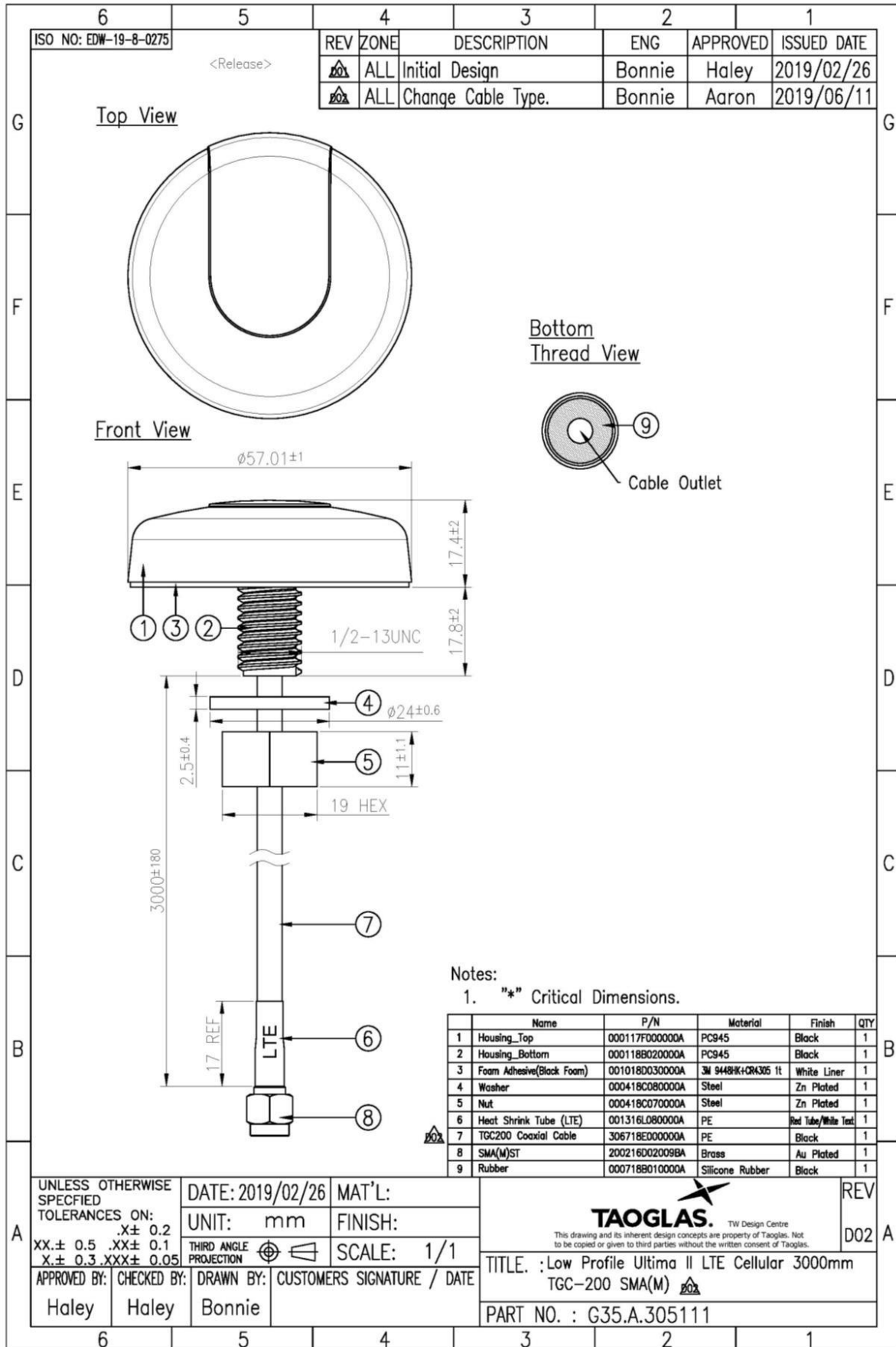

## 6. Packaging

1pcs G35.A.305111 per PE Bag  
 Dimensions - 300\*160mm  
 Weight - 160g



40pcs G35.A.305111 per carton  
 Dimensions - 390\*270\*330mm  
 Weight - 6.9Kg

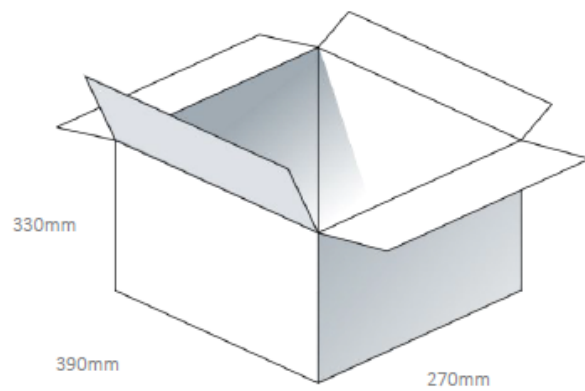

Pallet Dimensions:  
 1200\*1000\*1190mm  
 27 Cartons Per Pallet  
 9 Cartons Per Layer, 3 Layers

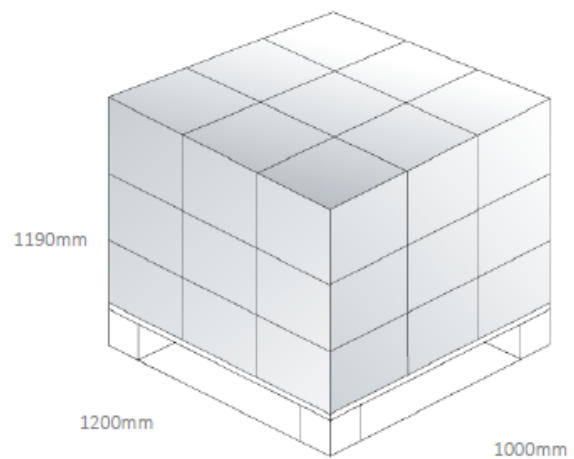

Changelog for the datasheet

**SPE-18-8-069 – G35.A.305111**

**Revision: E (Current Version)**

Date:	2023-06-15
Changes:	Updated Antenna Characteristics Updated Radiation Patterns
Changes Made by:	Aswin Biju

**Previous Revisions**

**Revision: D**

Date:	2019-09-06
Changes:	Updated EDW
Changes Made by:	Jack Conroy

**Revision: C**

Date:	2018-09-14
Changes:	Updated Part Number & Cable Type
Changes Made by:	Jack Conroy

**Revision: B**

Date:	2018-08-17
Changes:	
Changes Made by:	Jack Conroy

**Revision: A (Original First Release)**

Date:	2018-07-19
Notes:	
Author:	Jack Conroy