

FEATURES

- > Durable tungsten contacts improve load switching capability**
- > Latching coil means low drive power consumption
- > Mounting options in any axis
- > Solder or convenient threaded HV connections

PRODUCT SPECIFICATIONS

Contact & Relay Ratings	Units	G8L
Contact Form		R
Contact Arrangement		SPDT
Contact Material (moveable/stationary)		molybdenum /tungsten
Dielectric		Vacuum
Voltage, Test Max., Contacts & to Base (15 µA Leakage Max.) dc or 60Hz	kV Peak	17
Voltage, Operating Max., Contacts & to Base (15 µA Leakage Max.)		
dc or 60 Hz	kV Peak	15
2.5 MHz	kV Peak	12
16 MHz	kV Peak	9
32 MHz	kV Peak	7
Current, Load Switching		Contact factory**
Current, Continuous Carry Max		
dc or 60 Hz	Amps	30
2.5 MHz	Amps	18
16 MHz	Amps	10
32 MHz	Amps	6
Coil Hi-Pot (V RMS, 60 Hz)	V	500
Capacitance		
Across Open Contacts	pF	.05
Contacts to Ground	pF	1
Resistance, Contact Max @ 1A, 28 Vdc	ohms	0.025
Latch Time	ms	15
Reset Time	ms	9
Life, Mechanical	cycles	1 million
Weight, Nominal	g (oz)	84 (3)
Vibration, Operating, Sine (55-500 Hz Peak)	G's	10
Shock, Operating, 1/2 Sine 11ms (Peak)	G's	50
Temperature Ambient Operating	°C	-55 to +125

** Consult factory for load switching applications.

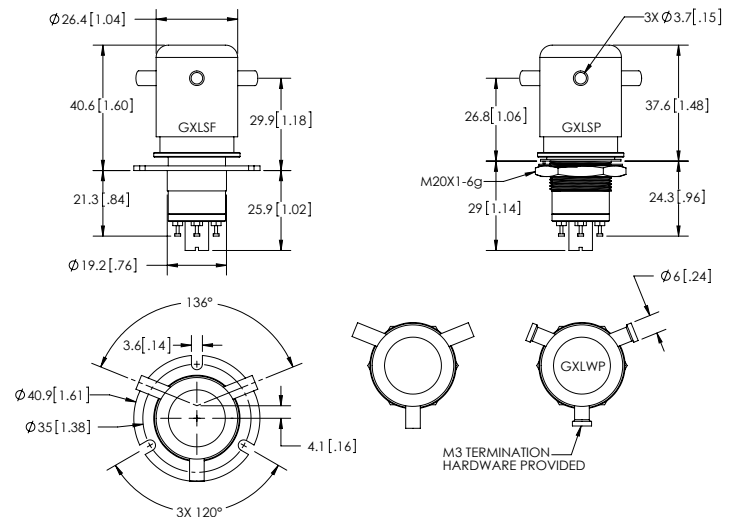

COIL RATINGS

Nominal, Volts dc	26.5
Latch, Volts dc, Max.	16
Reset, Volts dc	1 - 10
Coil Resistance (Ohms ±10%)	

PART NUMBER SYSTEM

G8L	S	P	
High Voltage/Power Terminal Connections	S = Solder Pot W = Screw		
Mounting		P = Through Panel F = Flange	
Coil Voltage*			Blank = 26.5 Vdc

* Order the relay with the part number as shown. The latching "L" designator and the coil voltage will not appear in the P/N on the relay but will be indicated on the label that is on the base of the relay. Observe coil polarity.

Datasheets provided by Sensata Technologies, Inc., its subsidiaries and/or affiliates (“Sensata”) are solely intended to assist third parties (“Buyers”) who are developing systems that incorporate Sensata products (also referred to herein as “components”). Buyer understands and agrees that Buyer remains responsible for using its independent analysis, valuation, and judgment in designing Buyer’s systems and products. Sensata datasheets have been created using standard laboratory conditions and engineering practices. Sensata has not conducted any testing other than that specifically described in the published documentation for a particular datasheet. Sensata may make corrections, enhancements, improvements, and other changes to its datasheets or components without notice.

Buyers are authorized to use Sensata datasheets with the Sensata component(s) identified in each particular datasheet. HOWEVER, NO OTHER LICENSE, EXPRESS OR IMPLIED, BY ESTOPPEL OR OTHERWISE TO ANY OTHER SENSATA INTELLECTUAL PROPERTY RIGHT, AND NO LICENSE TO ANY THIRD PARTY TECHNOLOGY OR INTELLECTUAL PROPERTY RIGHT, IS GRANTED HEREIN. SENSATA DATASHEETS ARE PROVIDED “AS IS”. SENSATA MAKES NO WARRANTIES OR REPRESENTATIONS WITH REGARD TO THE DATASHEETS OR USE OF THE DATASHEETS, EXPRESS, IMPLIED, OR STATUTORY, INCLUDING ACCURACY OR COMPLETENESS. SENSATA DISCLAIMS ANY WARRANTY OF TITLE AND ANY IMPLIED WARRANTIES OF MERCHANTABILITY, FITNESS FOR A PARTICULAR PURPOSE, QUIET ENJOYMENT, QUIET POSSESSION, AND NON-INFRINGEMENT OF ANY THIRD PARTY INTELLECTUAL PROPERTY RIGHTS WITH REGARD TO SENSATA DATASHEETS OR USE THEREOF.

All products are sold subject to Sensata’s terms and conditions of sale supplied at www.sensata.com. SENSATA ASSUMES NO LIABILITY FOR APPLICATIONS ASSISTANCE OR THE DESIGN OF BUYERS’ PRODUCTS. BUYER ACKNOWLEDGES AND AGREES THAT IT IS SOLELY RESPONSIBLE FOR COMPLIANCE WITH ALL LEGAL, REGULATORY, AND SAFETY-RELATED REQUIREMENTS CONCERNING ITS PRODUCTS, AND ANY USE OF SENSATA COMPONENTS IN ITS APPLICATIONS, NOTWITHSTANDING ANY APPLICATIONS-RELATED INFORMATION OR SUPPORT THAT MAY BE PROVIDED BY SENSATA.

Mailing Address: Sensata Technologies, Inc., 529 Pleasant Street, Attleboro, MA 02703, USA

CONTACT US

Regional head offices:

United States of America

Sensata Technologies

Attleboro, MA

Phone: 508-236-3800

E-mail: support@sensata.com

Netherlands

Sensata Technologies Holland B.V.

Hengelo

Phone: +31 74 357 8000

E-mail: support@sensata.com

China

Sensata Technologies China Co., Ltd.

Shanghai

Phone: +8621 2306 1500

E-mail: support@sensata.com

Copyright © 2023 Sensata Technologies, Inc.