

	<b>E502650</b>
---	----------------

**Features**

- Halogen Free Available Upon Request By Adding Suffix "-HF"
- Lead Free Finish/RoHS Compliant (Note1) ("P" Suffix Designates Compliant. See Ordering Information)
- Epoxy Meets UL 94 V-0 Flammability Rating
- Moisture Sensitivity Level 1
- High Surge Forward Current Capability

**Maximum Ratings**

- Operating Junction Temperature Range: -55°C to +150°C
- Storage Temperature Range: -55°C to +150°C
- Thermal Resistance: 1.5°C/W Junction to Case
- Thermal Resistance: 22°C/W Junction to Ambient

**Mechanical Data**

- Mounting Torque: 0.5 N•m

MCC Part Number	Device Marking	Maximum Recurrent Peak Reverse Voltage	Maximum RMS Voltage	Maximum DC Blocking Voltage
GBJA6005	GBJA6005	50V	35V	50V
GBJA601	GBJA601	100V	70V	100V
GBJA602	GBJA602	200V	140V	200V
GBJA604	GBJA604	400V	280V	400V
GBJA606	GBJA606	600V	420V	600V
GBJA608	GBJA608	800V	560V	800V
GBJA610	GBJA610	1000V	700V	1000V

**Electrical Characteristics @ 25°C Unless Otherwise Specified**

Average Forward Current	$I_{F(AV)}$	6A	$T_C = 100^\circ C$
Peak Forward Surge Current	$I_{FSM}$	135A	8.3ms, Half Sine
Maximum Instantaneous Forward Voltage	$V_F$	1.1V	$I_{FM} = 3.0A; T_J = 25^\circ C$
Maximum DC Reverse Current At Rated DC Blocking Voltage	$I_R$	5μA	$T_J = 25^\circ C$
$I^2t$ Rating for fusing	$I^2t$	75A <sup>2</sup> S	(1ms < t < 8.3ms)

Note: 1. High Temperature Solder Exemption Applied, See EU Directive Annex Notes 7a.

**6 Amp  
Glass Passivated  
Bridge Rectifier  
50 - 1000 Volts**

JA

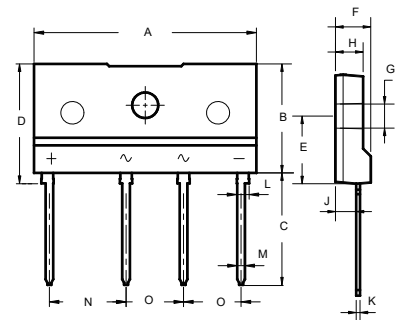

DIM	DIMENSIONS				NOTE
	INCHES		MM		
	MIN	MAX	MIN	MAX	
A	1.130	1.154	28.70	29.30	
B	0.559	0.583	14.20	14.80	
C	0.575	0.598	14.60	15.20	
D	0.614	0.638	15.60	16.20	
E	0.343	0.366	8.70	9.30	
F	0.169	0.193	4.30	4.90	
G	0.122	0.134	3.10	3.40	
H	0.130	0.154	3.30	3.90	
J	0.098	0.114	2.50	2.90	
K	0.012	0.024	0.40	0.60	
L	0.059	0.067	1.50	1.70	
M	0.035	0.043	0.90	1.10	
N	0.390	0.400	9.80	10.20	
O	0.290	0.300	7.30	7.70	

**Curve Characteristics**

Fig. 1 - Forward Current Derating Curve

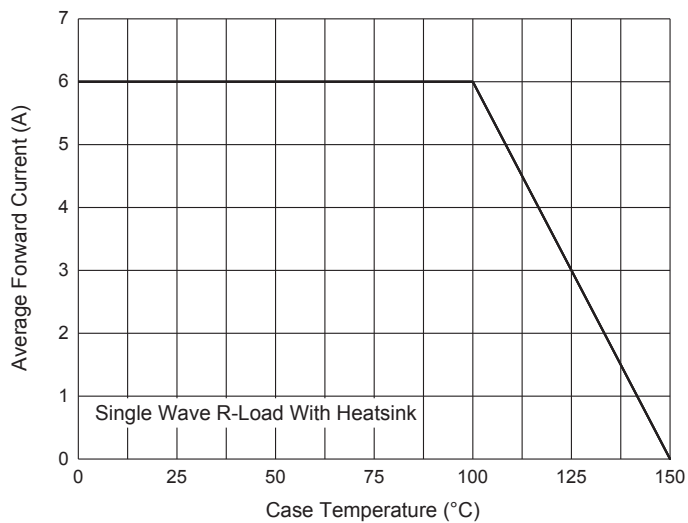

Fig. 2 - Maximum Non-Repetitive Peak Forward Surge Current

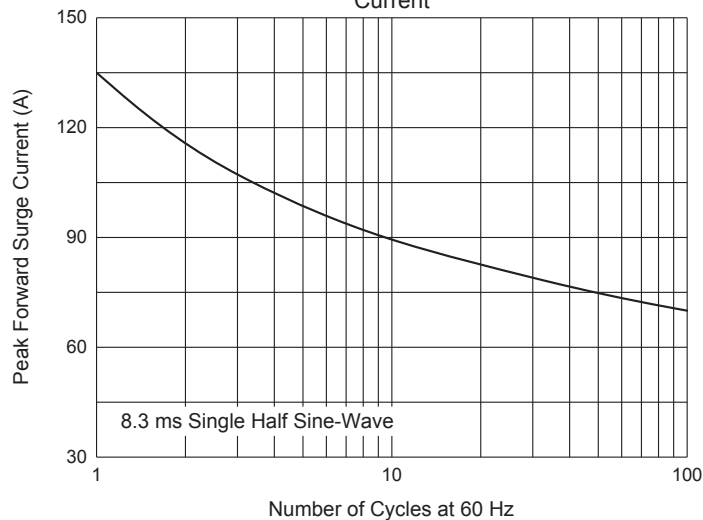

Fig. 3 - Typical Instantaneous Forward Characteristics

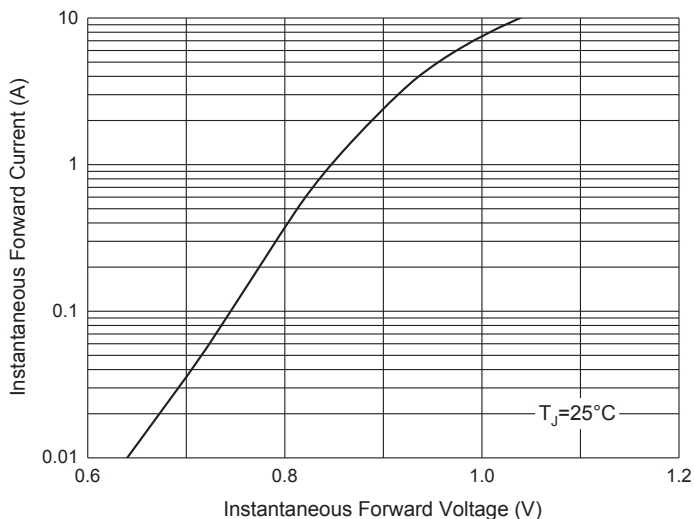

Fig. 4 - Typical Reverse Leakage Characteristics

