

40A, 50A, 50V - 1000V Standard Bridge Rectifier

FEATURES

- Glass passivated chip junction
- Integrally molded heatsink provide very low thermal resistance for maximum heat dissipation
- Universal 4-way terminals: snap-on, wrap-around, solder or P.C. board mounting
- High surge current capability
- UL Recognized File # E-326243
- RoHS Compliant

APPLICATIONS

- Switching mode power supply (SMPS)
- AC to DC converter

MECHANICAL DATA

- Case: GBPC40
GBPC40-M: Terminal cathode parallel to anode
- Molding compound meets UL 94V-0 flammability rating
- Terminal: Matte tin plated leads, solderable per J-STD-002
- Meet JESD 201 class 1A whisker test
- Mounting torque: 20 in-lbs maximum
- Polarity: As marked
- Weight: 17.30g (approximately)

KEY PARAMETERS		
PARAMETER	VALUE	UNIT
I_F	40, 50	A
V_{RRM}	50 - 1000	V
I_{FSM}	400	A
T_{JMAX}	150	°C
Package	GBPC40	
Configuration	Quad	

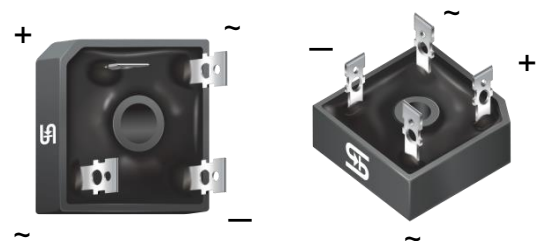

GBPC40

GBPC40-M

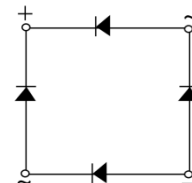

ABSOLUTE MAXIMUM RATINGS ($T_A = 25^\circ\text{C}$ unless otherwise noted)

PARAMETER	SYMBOL	GBPC40, 50							UNIT
		005	01	02	04	06	08	10	
Repetitive peak reverse voltage	V_{RRM}	50	100	200	400	600	800	1000	V
Reverse voltage, total rms value	$V_{R(RMS)}$	35	70	140	280	420	560	700	V
Forward current	GBPC40	40							A
	GBPC50	50							A
Peak forward surge current, 8.3ms single half sine-wave superimposed on rated load	I_{FSM}	400							A
Rating for fusing ($t < 8.3\text{ms}$)	I^2t	664							A^2s
Junction temperature	T_J	- 55 to +150							°C
Storage temperature	T_{STG}	- 55 to +150							°C

THERMAL PERFORMANCE			
PARAMETER	SYMBOL	TYP	UNIT
Junction-to-case thermal resistance	$R_{\theta JC}$	1.5	°C/W

ELECTRICAL SPECIFICATIONS ($T_A = 25^\circ\text{C}$ unless otherwise noted)						
PARAMETER		CONDITIONS	SYMBOL	TYP	MAX	UNIT
Forward voltage per diode ⁽¹⁾	GBPC40	$I_F = 20\text{A}, T_J = 25^\circ\text{C}$	V_F	-	1.1	V
	GBPC50	$I_F = 25\text{A}, T_J = 25^\circ\text{C}$		-	1.1	V
Reverse current @ rated V_R per diode ⁽²⁾		$T_J = 25^\circ\text{C}$	I_R	-	10	μA

Notes:

1. Pulse test with $PW = 0.3\text{ms}$
2. Pulse test with $PW = 30\text{ms}$

ORDERING INFORMATION		
ORDERING CODE⁽¹⁾	PACKAGE	PACKING
GBPC*x	GBPC40	50 / Tray
GBPC*xM	GBPC40-M	50 / Tray

Notes:

1. "*" defines current from 40A (GBPC40x/ GBPC40xM) to 50A (GBPC50x/GBPC50xM),
 "x" defines voltage from 50V(GBPC*005/ GBPC*005M) to 1000V(GBPC*10/GBPC*10M)

CHARACTERISTICS CURVES

($T_A = 25^\circ\text{C}$ unless otherwise noted)

Fig.1 Forward Current Derating Curve

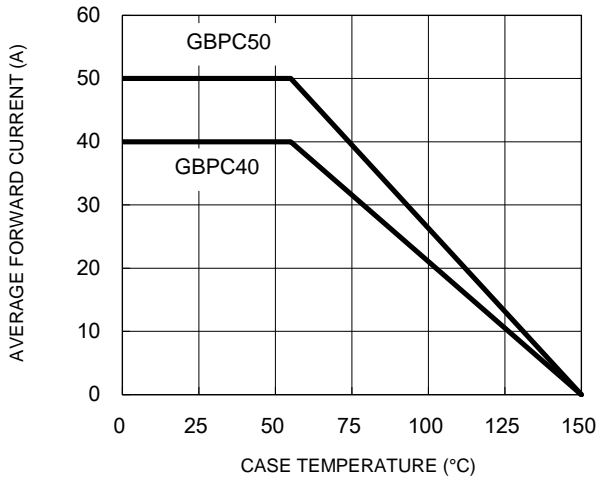

Fig.2 Typical Junction Capacitance

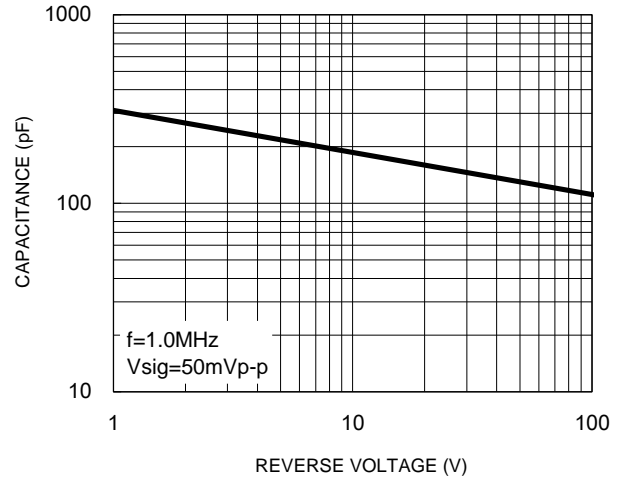

Fig.3 Typical Reverse Characteristics

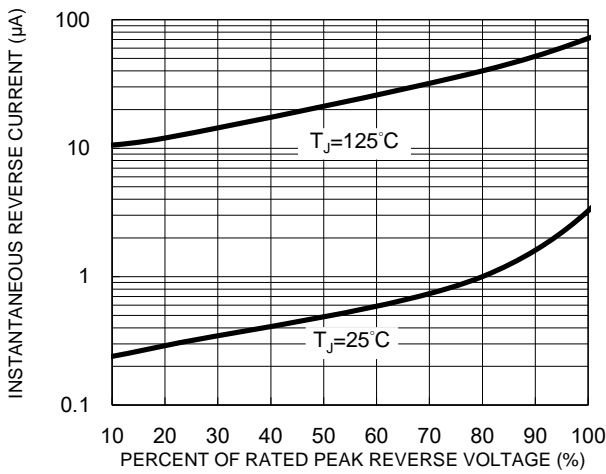

Fig.4 Typical Forward Characteristics

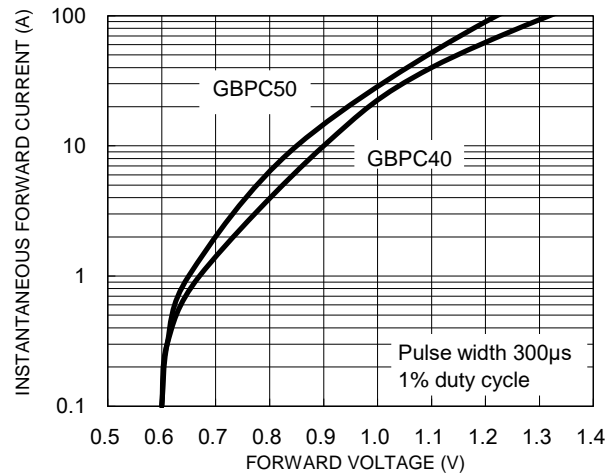
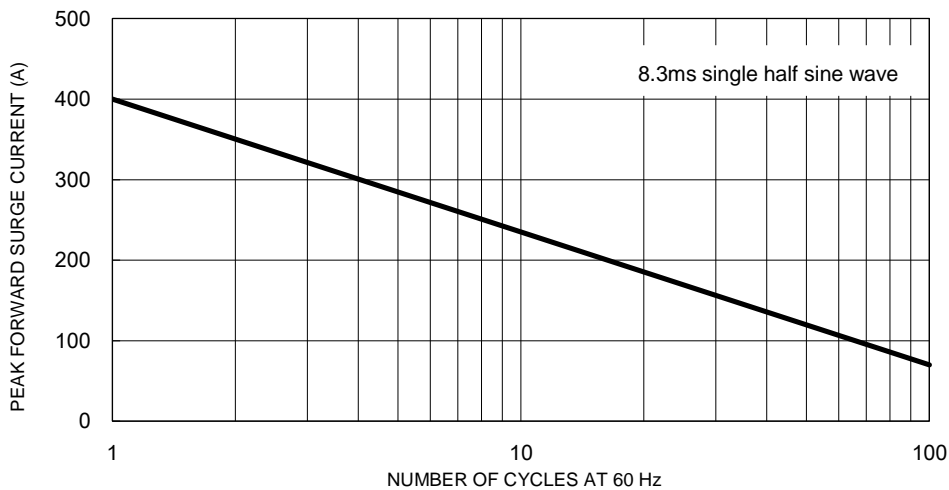
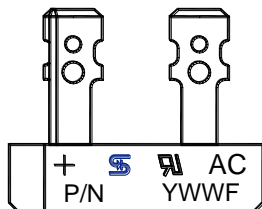
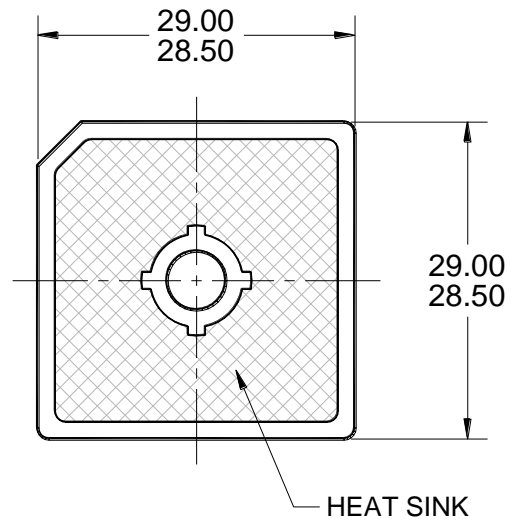
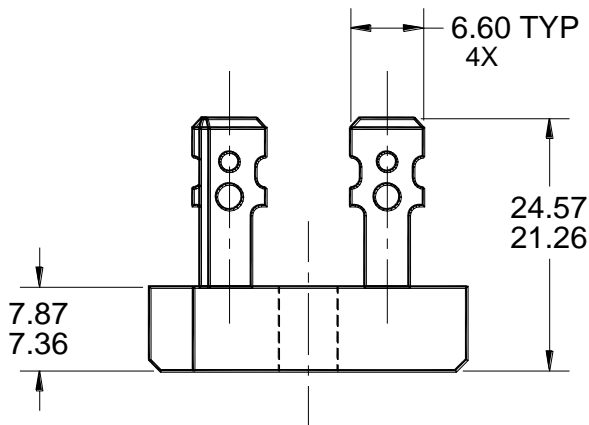
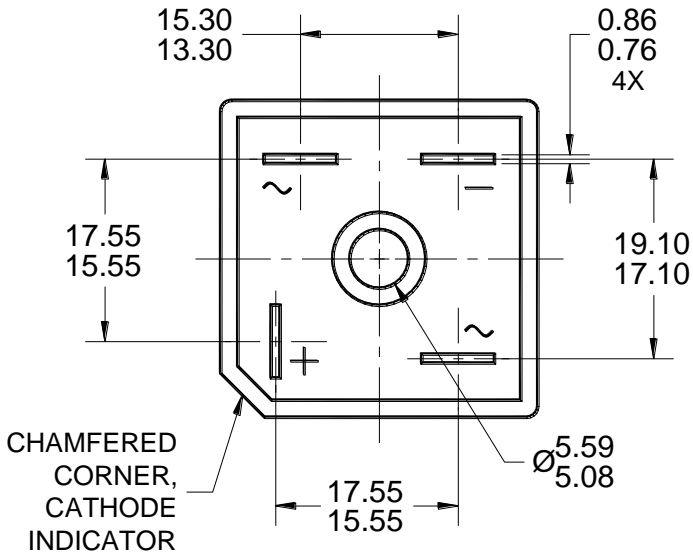

Fig.5 Maximum Non-Repetitive Forward Surge Current



PACKAGE OUTLINE DIMENSIONS

GBPC40



MARKING DIAGRAM

P/N = MARKING CODE
YWW = DATE CODE
F = FACTORY CODE

NOTES: UNLESS OTHERWISE SPECIFIED

1. ALL DIMENSIONS ARE IN MILLIMETERS.
2. DIMENSIONING AND TOLERANCING PER ASME Y14.5M-1994.
3. DWG NO. REF: HQ2SD07-GBPC40-052 REV A.

PACKAGE OUTLINE DIMENSIONS

GBPC40-M

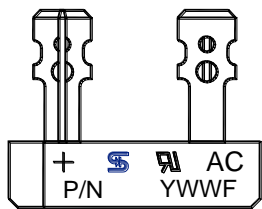
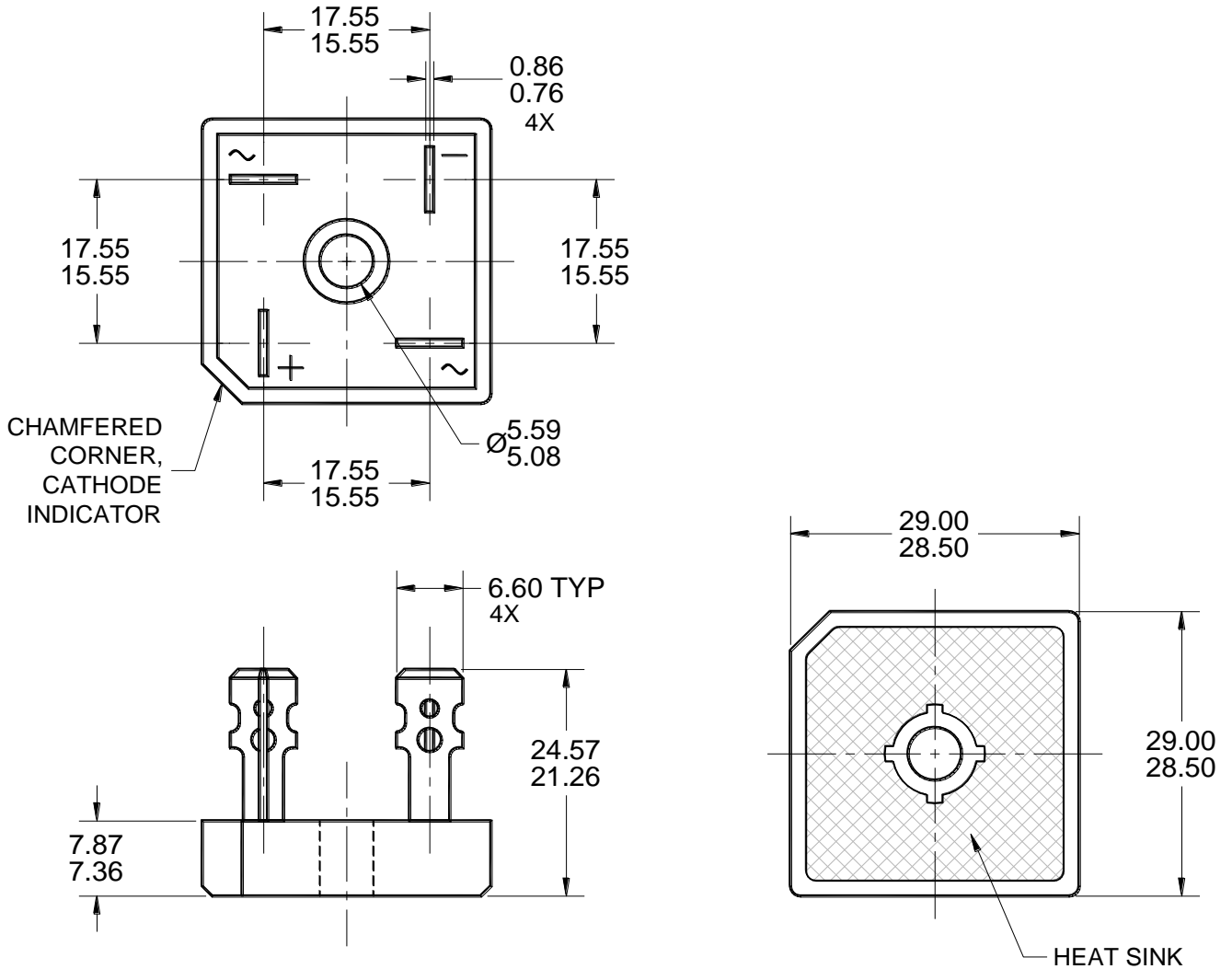

MARKING DIAGRAM

P/N = MARKING CODE
 YWW = DATE CODE
 F = FACTORY CODE

NOTES: UNLESS OTHERWISE SPECIFIED

1. ALL DIMENSIONS ARE IN MILLIMETERS.
2. DIMENSIONING AND TOLERANCING PER ASME Y14.5M-1994.
3. DWG NO. REF: HQ2SD07-GBPC40M-053 REV A.