

	<b>E502650</b>
-----------------------------------------------------------------------------------	----------------

**Features**

- Halogen Free Available Upon Request By Adding Suffix "-HF"
- Lead Free Finish/RoHS Compliant (Note1) ("P" Suffix Designates Compliant. See Ordering Information)
- High Surge Forward Current Capability
- Epoxy Meets UL 94 V-0 Flammability Rating
- Moisture Sensitivity Level 1

**Maximum Ratings**

- Operating Junction Temperature Range: -55°C to +150°C
- Storage Temperature Range: -55°C to +150°C
- Typical Thermal Resistance: 2.2°C/W Junction to Case(Heatsink)

**Mechanical Data**

- Mounting Torque: 5in-lbs

MCC Part Number	Maximum Recurrent Peak Reverse Voltage	Maximum RMS Voltage	Maximum DC Blocking Voltage
GBU20005	50V	35V	50V
GBU2001	100V	70V	100V
GBU2002	200V	140V	200V
GBU2004	400V	280V	400V
GBU2006	600V	420V	600V
GBU2008	800V	560V	800V
GBU2010	1000V	700V	1000V

**Electrical Characteristics @ 25°C Unless Otherwise Specified**

Maximum Average Forward Current (With Heatsink)	$I_{F(AV)}$	20A	$T_C = 100^\circ C$
Peak Forward Surge Current	$I_{FSM}$	240A	8.3ms, Half Sine
Maximum Instantaneous Forward Voltage	$V_F$	1.1V	$I_{FM} = 10A$ $T_A = 25^\circ C$
Maximum DC Reverse Current At Rated DC Blocking Voltage	$I_R$	5 $\mu A$ 500 $\mu A$	$T_A = 25^\circ C$ $T_A = 125^\circ C$
Typical Junction Capacitance	$C_J$	70pF	Measured at 1.0MHz, $V_R = 4.0V$
Rating for Fusing	$I^2t$	239A <sup>2</sup> s	$t < 8.3ms$

Note: 1. High Temperature Solder Exemption Applied, See EU Directive Annex Notes 7

**20 Amp Single Phase Glass Passivated Bridge Rectifiers 50 to 1000 Volts**

**GBU**

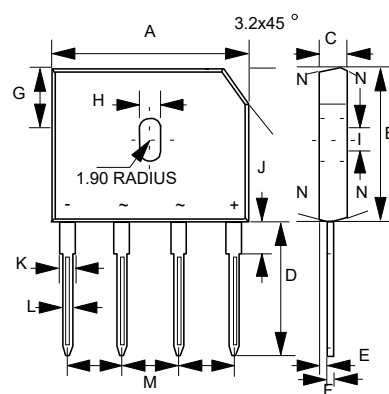

DIM	DIMENSIONS				NOTE
	INCHES		MM		
	MIN	MAX	MIN	MAX	
A	0.860	0.880	21.80	22.30	
B	0.720	0.740	18.30	18.80	
C	0.130	0.142	3.30	3.60	
D	0.690	0.717	17.50	18.20	
E	0.030	0.039	0.76	1.00	
F	0.018	0.024	0.46	0.60	
G	0.290	0.310	7.40	7.90	
H	0.140	0.160	3.50	4.10	
I	0.065	0.085	1.65	2.16	
J	0.060	0.096	1.52	2.45	
K	0.077	0.098	1.95	2.50	
L	0.040	0.050	1.02	1.27	
M	0.190	0.210	4.83	5.33	
N	7.0° TYPICAL				

**Curve Characteristics**

Fig. 1 - Forward Current Derating Curve

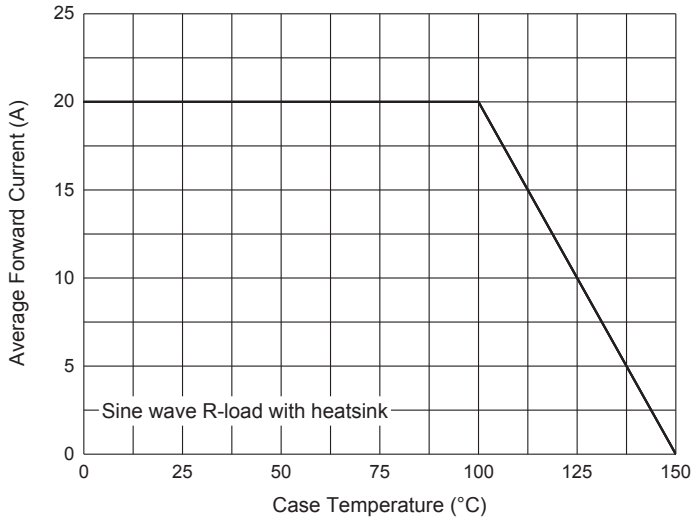

Fig. 2 - Maximum Non-Repetitive Peak Forward Surge Current

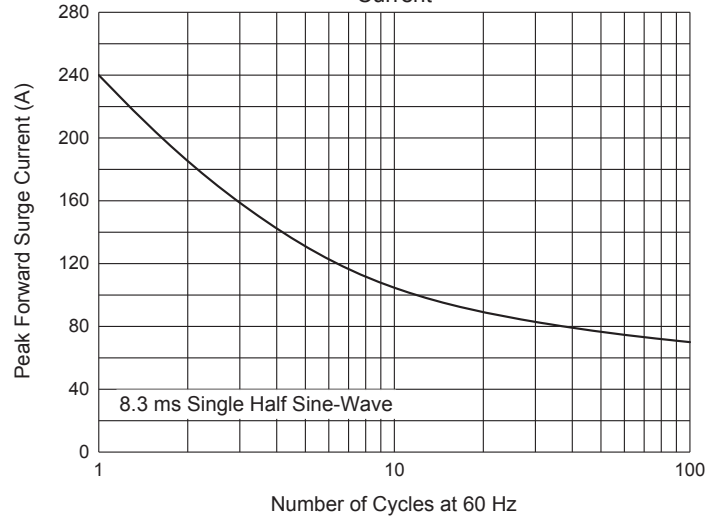

Fig. 3 - Typical Instantaneous Forward Characteristics

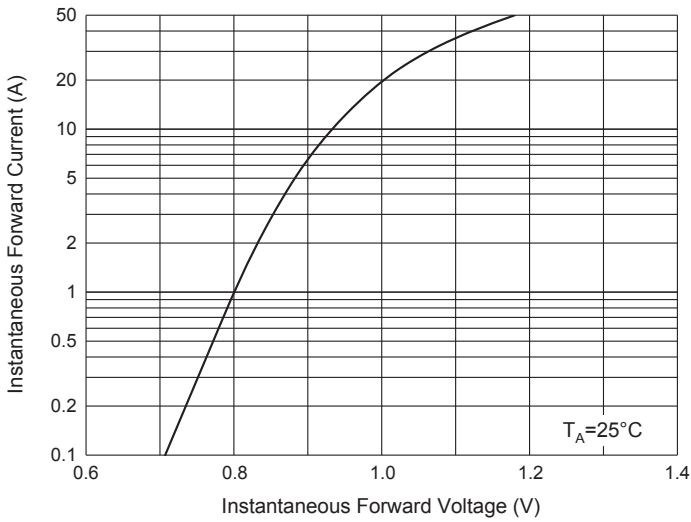

Fig. 4 - Typical Reverse Leakage Characteristics

