

**GigaDevice Semiconductor Inc.**

**GD30WS8805x**  
**PMIC for TWS Headset Charging Box**

Datasheet

## Table of Contents

<b>Table of Contents</b> .....	<b>2</b>
<b>List of Figures</b> .....	<b>4</b>
<b>List of Tables</b> .....	<b>5</b>
<b>1 Features</b> .....	<b>6</b>
<b>2 Applications</b> .....	<b>6</b>
<b>3 General description</b> .....	<b>7</b>
<b>4 Device overview</b> .....	<b>8</b>
<b>4.1 Device information</b> .....	<b>8</b>
<b>4.2 Block diagram</b> .....	<b>8</b>
<b>4.3 Pinout and pin assignment</b> .....	<b>9</b>
<b>4.4 Pin definitions</b> .....	<b>9</b>
<b>5 Functional description</b> .....	<b>11</b>
<b>5.1 Operation modes</b> .....	<b>11</b>
<b>5.2 Battery charging</b> .....	<b>11</b>
5.2.1 Battery charger state .....	11
5.2.2 Charge parameters .....	12
<b>5.3 Synchronous boost converter</b> .....	<b>13</b>
<b>5.4 Power path management</b> .....	<b>14</b>
5.4.1 Power path management .....	14
5.4.2 LDO .....	14
<b>5.5 Earbud detection</b> .....	<b>15</b>
<b>5.6 NTC battery temperature</b> .....	<b>15</b>
<b>5.7 LED driver</b> .....	<b>16</b>
5.7.1 LED connection and display mode .....	16
5.7.2 LED Display Mode Configuration .....	18
5.7.3 LED Driving Capability Configuration .....	18
5.7.4 LED Display Control by I2C .....	19
<b>5.8 Earbud communication</b> .....	<b>19</b>
<b>5.9 EN and IRQ</b> .....	<b>20</b>
<b>5.10 Over temperature protection</b> .....	<b>20</b>
<b>5.11 I2C interface</b> .....	<b>20</b>

<b>5.12</b>	<b>Register Map .....</b>	<b>21</b>
5.12.1	Fault Register.....	21
5.12.2	Status Register 1 .....	23
5.12.3	Status Register 2 .....	24
5.12.4	Control Register .....	25
5.12.5	User configure Register 1 .....	26
5.12.6	User configure Register 2 .....	26
5.12.7	User configure Register 3 .....	27
5.12.8	Watchdog Register .....	28
5.12.9	COML/R Register.....	28
5.12.10	LED Register .....	29
5.12.11	ADC Register .....	30
5.12.12	DEBUG Register.....	30
<b>6</b>	<b>Electrical characteristics.....</b>	<b>32</b>
6.1	Absolute maximum ratings .....	32
6.2	Recommended operation conditions .....	32
6.3	Electrical sensitivity .....	32
6.4	Power supplies voltages and currents.....	33
6.5	Logic input characteristics.....	33
6.6	Open drain outputs characteristics.....	33
6.7	NTC characteristics.....	33
6.8	Switching charger characteristics.....	34
6.9	Boost converter characteristics .....	35
6.10	ADC characteristics.....	36
6.11	Timing characteristics.....	37
6.12	Earbud Output Switch characteristics.....	37
6.13	I2C characteristics .....	37
6.14	Protection features .....	38
<b>7</b>	<b>Typical application circuit .....</b>	<b>40</b>
<b>8</b>	<b>Layout guideline .....</b>	<b>41</b>
<b>9</b>	<b>Package information.....</b>	<b>42</b>
9.1	QFN24 package information.....	42
9.2	Thermal characteristics .....	44
<b>10</b>	<b>Ordering information.....</b>	<b>45</b>
<b>11</b>	<b>Revision history.....</b>	<b>46</b>

## List of Figures

Figure 4-1 Block diagram for GD30WS8805x .....	8
Figure 4-2 GD30WS8805x QFN24 pinouts .....	9
Figure 5-1 Operation modes.....	11
Figure 5-2 Battery charge state diagram.....	12
Figure 5-3 Battery charge cycle and charge parameters .....	13
Figure 5-4 The principle diagram for LDO .....	15
Figure 5-5 Diagram for the NTC circuit.....	15
Figure 5-6 1-LED Mode.....	16
Figure 5-7 2-LED Mode.....	16
Figure 5-8 3-LED Mode.....	17
Figure 5-9 4-LED Mode.....	17
Figure 5-10 The communication block diagram of COML and EBL .....	19
Figure 5-11 I2C communication flow .....	21
Figure 6-1 Constant current charging efficiency .....	34
Figure 6-2 Constant current charging chip case temperature.....	35
Figure 6-3 BOOST conversion efficiency.....	36
Figure 6-4 I2C bus timing diagram.....	37
Figure 7-1 Typical GD30WS8805x application circuit.....	40
Figure 8-1 Typical GD30WS8805x layout guideline .....	41
Figure 9-1 QFN24 package outline.....	42
Figure 9-2 QFN24 recommended footprint .....	43

## List of Tables

Table 4-1 Device information for GD30WS8805x .....	8
Table 4-2 GD30WS8805x QFN24 pin definitions .....	9
Table 5-1 Description of resistors for the NTC circuit .....	15
Table 5-2 1-LED Display Mode.....	16
Table 5-3 2-LED Display Mode.....	17
Table 5-4 3-LED Display Mode.....	17
Table 5-5 4-LED Display Mode.....	18
Table 5-6 LED Display Mode Register .....	18
Table 5-7 LED Driving Register .....	18
Table 5-8 LED Control Register .....	19
Table 6-1 Absolute maximum ratings .....	32
Table 6-2 Recommended operation conditions.....	32
Table 6-3 Electrostatic Discharge characteristics.....	33
Table 6-4 Power supplies voltages and currents .....	33
Table 6-5 Logic input characteristics .....	33
Table 6-6 Open drain output characteristics .....	33
Table 6-7 NTC characteristics .....	33
Table 6-8 Charger characteristics .....	34
Table 6-9 Boost converter characteristics .....	35
Table 6-10 ADC characteristics .....	36
Table 6-11 Timing characteristics .....	37
Table 6-12 Earbud output switch characteristics.....	37
Table 6-13 I2C characteristics .....	37
Table 6-14 Protection features characteristics .....	38
Table 9-1 QFN24 dimensions .....	42
Table 9-2 Package thermal characteristics <sup>(1)</sup> .....	44
Table 10-1 Part ordering code for GD30WS8805x devices.....	45
Table 11-1 Revision history .....	46

## 1 Features

- Extreme low quiescent current, <math><5\mu\text{A}</math> in sleep mode
- Charging features
  - Switching charging up to 1.2A maximum current programmable through ISET
  - Support variety of battery chemistries, 4.1/4.2/4.3/4.35/4.4V @0.5%
  - Full charge cycle: pre-charge, constant current and constant voltage
  - Charging current and pre-charging current are all programmable through I2C
- Boost converter
  - Support up to 600mA load current
  - High efficiency synchronous boost converter @95%
  - Output current limit programmable through I2C, 1.6A/1.8A/2.0A/2.2A
- Power path management
  - Power path management allows simultaneous battery charging and system supply, system discharge priority
  - When the system load increases, the charging current is reduced dynamically according to the input current and system voltage
  - USB current limit programmable through I2C, 95%/100%/105%/110% @ $I_{\text{CCCH}} + 0.5\text{A}$  (Maximum current 3A)
  - Over voltage protection up to 5.6V,  $V_{\text{SYS}}$  voltage regulation limit: 4.6V
- Protection features
  - Short Circuit Protection
  - Over/Under temperature protection
  - Input Over Voltage/Current Protection
  - Boost over voltage (OV) during charge @5.5V
  - Boost under voltage (UV) when charge/discharge @4.3V
- Additional features
  - 3.3V LDO support 50mA
  - Programmable LED driver
  - Low external component count
  - Simple I<sup>2</sup>C compatible interface

## 2 Applications

- TWS earbuds charging case
- Headsets and hearing aids
- Low battery applications such as smart watches and fitness accessories
- Patient monitors and portable medical equipment

### 3 General description

The GD30WS8805x is a highly integrated, programmable, low quiescent current power management integrated circuit (PMIC) that integrates the most common needs for wearables and low power battery applications.

The GD30WS8805x integrates a switching charger of programmable charging current (up to 1.2A) and a synchronous boost converter at fixed 5V output. The IC also includes a 12-bit ADC for battery gauge monitoring, and a low quiescent current, low noise LDO capable of delivering 50mA load current.

The device integrates advanced power path management and control that allow the device to provide power to the system while charging the battery even with poor adapters. The dynamic power path management automatically balances the currents delivered to the system and battery charging. A high voltage and over current protection circuit is implemented in the IC to protect it from high input voltage as high as 20V.

The GD30WS8805x device supports charge current up to 1.2A and termination current down to 5mA. The maximum charge current is set at a default of 1.2A and is programmable by connecting an external resistor from ISET pin to ground. The battery is charged using a standard Li-Ion charge profile with three phases: pre-charge, constant current and constant voltage regulation.

The device has several power saving modes to increase battery life whether the product is in storage or in operation. The quiescent current could be as low as 5uA when it is in sleep mode and thus most battery could sustain more than a year in shelf.

The versatile features of GD30WS8805x allow for it to best used in wearable applications such as headsets, earbuds and hearing aids, or low battery applications such as smart watches and fitness accessories, or patient monitors and portable medical equipment.

## 4 Device overview

### 4.1 Device information

Table 4-1 Device information for GD30WS8805x

Part Number	Package	Function	Description
GD30WS8805x	QFN24(4X4)	MCU version	Cooperate with MCU solution, supports EN enable control

### 4.2 Block diagram

Figure 4-1 Block diagram for GD30WS8805x

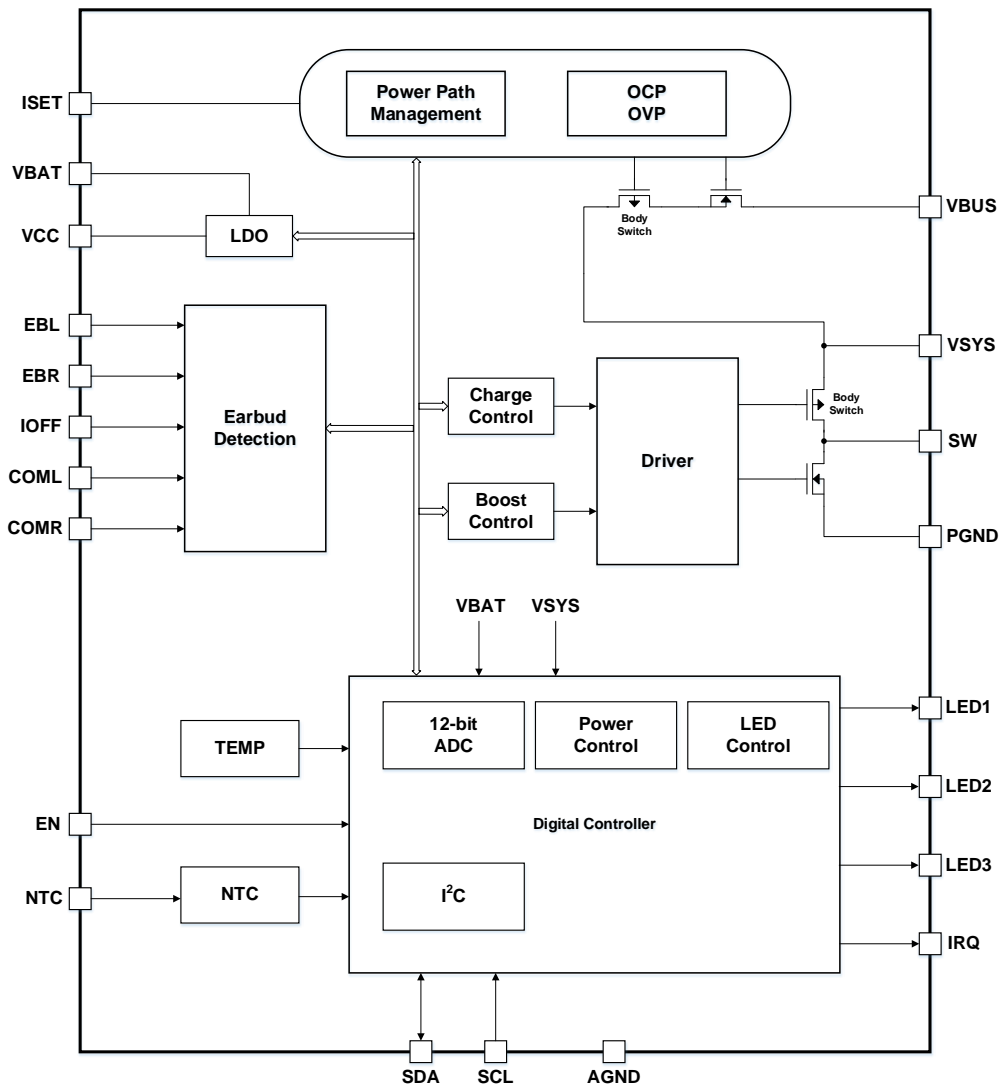



### 4.3 Pinout and pin assignment

Figure 4-2 GD30WS8805x QFN24 pinouts

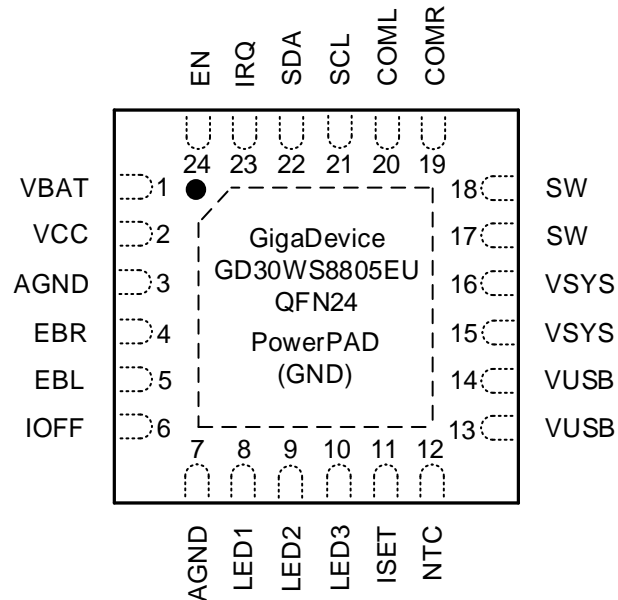

### 4.4 Pin definitions

Table 4-2 GD30WS8805x QFN24 pin definitions

Pin Name	Pins	Pin Type	Functions description
VBAT	1	P	Connect to positive node of a battery.
VCC	2	P	LDO output voltage, connect a capacitor to ground.
AGND	3	G	Ground.
EBR	4	I/O	Positive terminal for right earbud.
EBL	5	I/O	Positive terminal for left earbud.
IOFF	6	I	Set the termination current for BOOST.
AGND	7	G	Ground.
LED1	8	O	LED driver #1 for battery gauge monitor or other.
LED2	9	O	LED driver #2 for battery gauge monitor or other.
LED3	10	O	LED driver #3 for battery gauge monitor or other.
ISET	11	I	Set the charge current by connecting a resistor to ground.
NTC	12	I	Thermistor terminal voltage for battery, or pull high to DISABLE the IC.
VUSB	13,14	P	Power input from USB or 5-V voltage source.

VSYS	15,16	P	Output of boost converter or system voltage.
SW	17,18	P	Switching node, connecting to VBAT by an inductor.
COMR	19	I/O	Right earbud communication input and output.
COML	20	I/O	Left earbud communication input and output.
SCL	21	I	I2C communication to the host controller, clock.
SDA	22	I/O	I2C communication to the host controller, data.
IRQ	23	O	Interrupt output.
EN	24	I	IC enable.
PGND	EPAD	G	Device power ground.

**Notes:**

1. Type: I = input, O = output, I/O = input or output, P = power, G = Ground.

## 5 Functional description

### 5.1 Operation modes

The GD30WS8805x IC has three different operation modes: Sleep, Battery and USB operation mode, as shown in Figure 5-1.

Figure 5-1 Operation modes

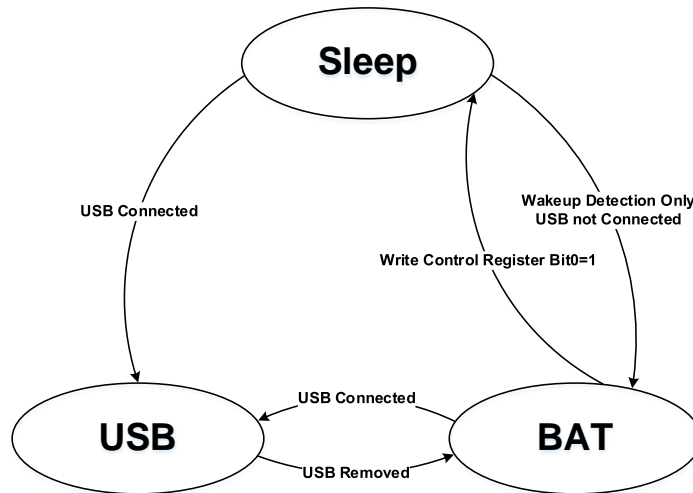

### 5.2 Battery charging

#### 5.2.1 Battery charger state

The GD30WS8805x device integrates a switching charger that allows the battery to be charged with a programmable charge current up to 1.2A. In addition to the charge current, other charging parameters can be also programmed through I2C such as the battery regulation voltage, pre-charge current. The device supports multiple battery regulation voltage regulation settings ( $V_{CVCH}$ ) and charge current ( $I_{CCCH}$ ) options to support multiple battery chemistries for single-cell applications. A full one-cell charger state diagram as shown in Figure 5-2 is implemented in the IC.

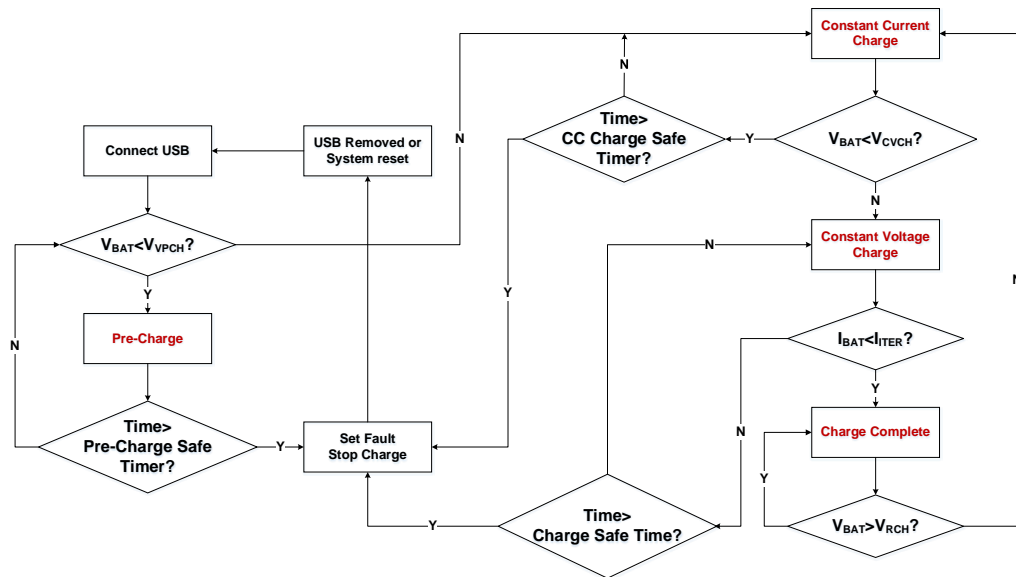
**Figure 5-2 Battery charge state diagram**

## 5.2.2 Charge parameters

The maximum charge current is programmed by a resistor connected from the ISET pin to ground. The earbud light load current is programmed by a resistor connected from the IOFF pin to ground. The resistor value can be calculated as:

$$R_{CCCH} = \frac{10}{I_{CCCH}} \text{ k}\Omega$$

$$I_{PCH} = \frac{I_{CCCH}}{10}$$

$$R_{IOFF} = \frac{500}{I_{IOFF}} \text{ k}\Omega$$

Where the unit of  $I_{CCCH}$  is A, the unit of  $I_{IOFF}$  is mA. The charge current also varies in different charging stages constant current loop (CC), constant voltage loop (CV). During the charging process, all control loops are enabled and the one that is dominant takes control regulating the charge current as needed. The relevant charge parameters and control loops are defined as in Figure 5-3.

Figure 5-3 Battery charge cycle and charge parameters

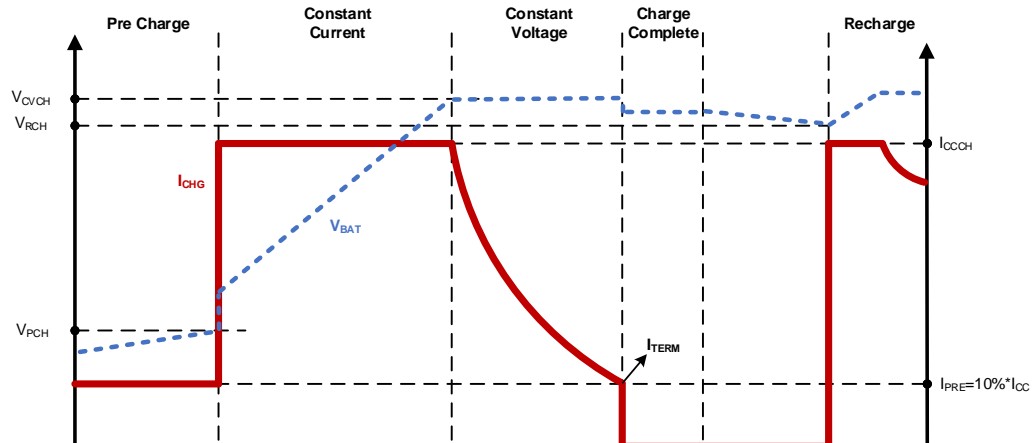

The charger input has back to back blocking FETs to prevent reverse current flow from VBAT to VUSB. They also integrate control circuitry regulating the input current and prevents excessive currents from being drawn from the USB power supply for more reliable operation.

### 5.3 Synchronous boost converter

The integrated synchronous boost converter is a wide input range, high-efficiency, DC-to-DC step-up switching regulator. It is capable of delivering up to 3W of output power, integrated with a 150mΩ high side PMOS and a 150 mΩ low side NMOS. It uses a PWM current-mode control scheme. An error amplifier integrates error between the internal feedback signal proportional to VSYS and the internal reference voltage. The output of the integrator is then compared to the sum of a current-sense signal and the slope compensation ramp. This operation generates a PWM signal that modulates the duty cycle of the power MOSFETs to achieve regulation for output voltage.

Integrated VBAT to VSYS synchronous boost output function, the output voltage is 5V, which can be set to 4.8V ~ 5.15V by I2C. The boost module integrates the current limiting function. When the load current is too large, the chip enters the cycle-by-cycle current limiting mode, limiting the peak inductor current to 2.0A, which can be configured to 1.6A/1.8A/2.0A/2.2A by I2C. At the same time, the output voltage starts to drop. When the output voltage drops to 4.3V, the short-circuit protection is triggered.

The boost module also integrates an overvoltage protection function. When the output voltage is higher than 5.5V, the overvoltage protection is triggered. When the voltage of the boost module drops below 2.8V during the working process of the booster module, the boost module is automatically closed and locked in the under voltage lockout state.

The boost regulator provides excellent stability over a wide range of output current and operates in DCM at light loads for excellent efficiency. The switching frequency is fixed at 1MHz to reduce the external inductor size. The boost regulator is disabled when USB voltage is detected to save power.

## 5.4 Power path management

### 5.4.1 Power path management

The device integrates advanced power path management and control that allows the device to provide power to the system while charging the battery even with low power adapters. The dynamic power path management is able to automatically balance the currents delivered to the system and battery charging.

The charging current can be set to  $I_{CCCH}$  through the off-chip resistor connected to the ISET pin, and the chip input current is limited to  $I_{CCCH} + 0.5A$  by the input current limit switch. In the charging and discharging mode, the system discharge priority. There are two situations that will cause the charging current to drop.

- 1) When the discharge current plus the rated charging is higher than  $I_{CCCH} + 0.5A$ , the dynamic path management loop automatically reduces the charging current to meet the discharge demand.
- 2) When the power supply capacity of the input adapter is lower than  $I_{CCCH} + 0.5A$ , and the rated charging current plus the VSYS discharge current is greater than the power supply capacity of the adapter, the VSYS voltage will drop, as the VSYS voltage drops to 4.6V, the charging current will be reduced through the feedback loop.

The chip also integrates the charging current temperature modulation function, when the chip temperature exceeds 110 degrees Celsius, the charging current is automatically reduced.

The input current limit switch also integrates short-circuit protection and over-current protection. When the current in the input switch exceeds 3A, the over-current protection is triggered. When the VSYS voltage drops below 4V, the short-circuit protection is triggered, the system stops working, and the input switch is closed. The chip enters hiccup mode and restarts every 250ms to check whether the abnormality exists. If the abnormality is removed, the chip returns to normal operation

### 5.4.2 LDO

A linear regulator is integrated to supply part of the chip and external circuits or MCU.

Output voltage of the LDO is 3.3V and the output driving current is 50mA. When output current exceeds 50mA, the output value will drop. When the chip works in sleep mode, LDO will enter low power mode to save power, which provides 10mA driving capability.

Figure 5-4 The principle diagram for LDO

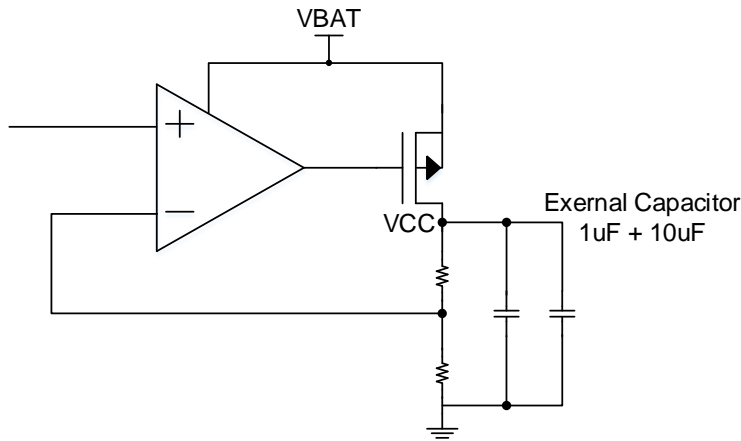

## 5.5 Earbud detection

The circuit detects the output current from EBL/EBR to show that earbud is inserted. EBL and EBR are independent channels which detect earbuds individually.

## 5.6 NTC battery temperature

The GD30WS8805x chip integrates an NTC battery temperature protection circuit, which provides the over-temperature protection of high temperature 55°C and low temperature -10°C. The corresponding high and low temperature threshold voltages are respectively 30% and 60% of the input system voltage. When the battery temperature exceeds 55°C or fall below -10°C, the correlative high or low temperature output will be set high separately. If NTC pin is pulled down to GND, the NTC function is closed.

Figure 5-5 Diagram for the NTC circuit

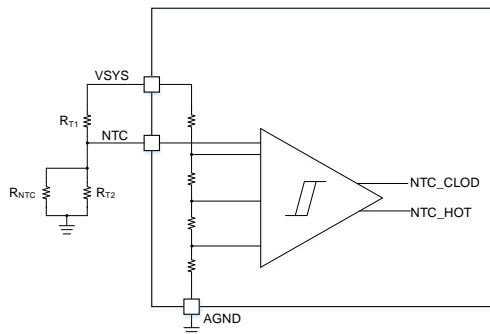

Table 5-1 Description of resistors for the NTC circuit

Symbol	Parameter	Typical value	Unit
R <sub>NTC</sub>	NTC thermistor	10	KΩ
R <sub>T1</sub>	Resistor for voltage division	5.23	KΩ
R <sub>T2</sub>	Resistor for voltage division	9.31	KΩ

## 5.7 LED driver

The chip supports 1-4 LED mode (see Table 5-2 to Table 5-5). The GD30WS8805x supports LED control by I2C (see Table 5-6 to Table 5-8).

### 5.7.1 LED connection and display mode

Figure 5-6 1-LED Mode

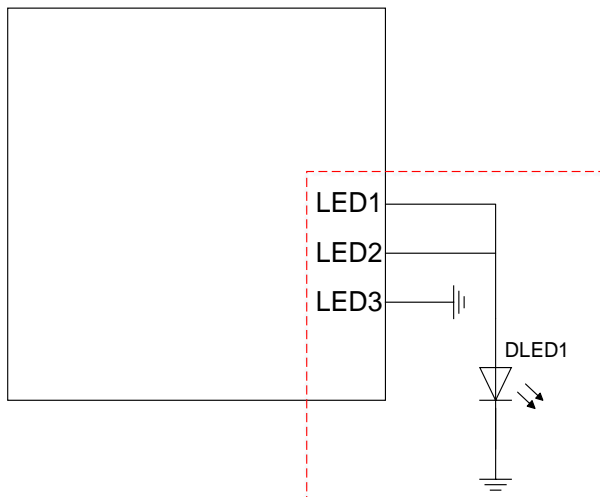
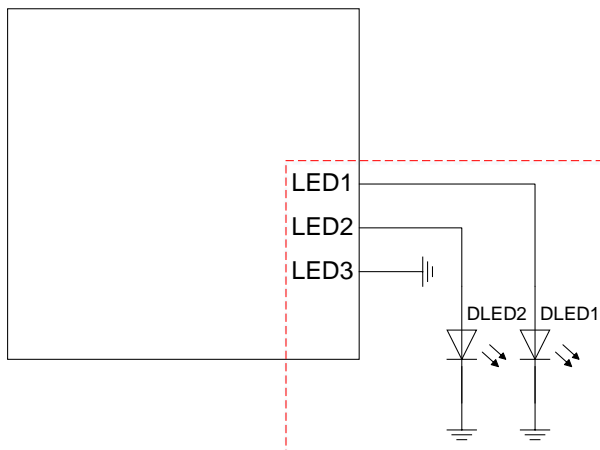

Table 5-2 1-LED Display Mode

Mode	Battery Status	DLED1
Charge	Full	Always On
	Charging	Blink at 1Hz
Discharge	Normal Power	On for 8s
	Low Battery	Blink at 1Hz for 8s
Earbud plug in	—	Blink at 1Hz for 1s

Figure 5-7 2-LED Mode

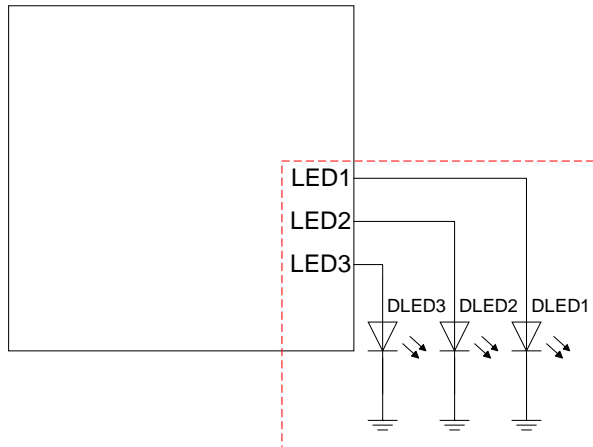



**Table 5-3 2-LED Display Mode**

Mode	Battery Status	DLED1	DLED2
Charge	Full	Off	Always On
	Charging	Off	Blink at 1Hz
Discharge	Normal Power	On for 8s	Off
	Low Battery	Blink at 1Hz for 8s	Off
Earbud plug in	—	Blink at 1Hz for 1s	

**Figure 5-8 3-LED Mode**



**Table 5-4 3-LED Display Mode**

Mode	Battery Level	DLED1	DLED2	DLED3
Charge	Full	Always On	Always On	Always On
	66%-100%	Always On	Always On	Blink at 1Hz
	33%-66%	Always On	Blink at 1Hz	Off
	0%-33%	Blink at 1Hz	Off	Off
Discharge	66%-100%	On for 8s	On for 8s	On for 8s
	33%-66%	On for 8s	On for 8s	Off
	5%-33%	On for 8s	Off	Off
	0%-5%	Blink at 1Hz for 8s	Off	Off
Earbud plug in	—	Blink at 1Hz for 1s		

**Figure 5-9 4-LED Mode**

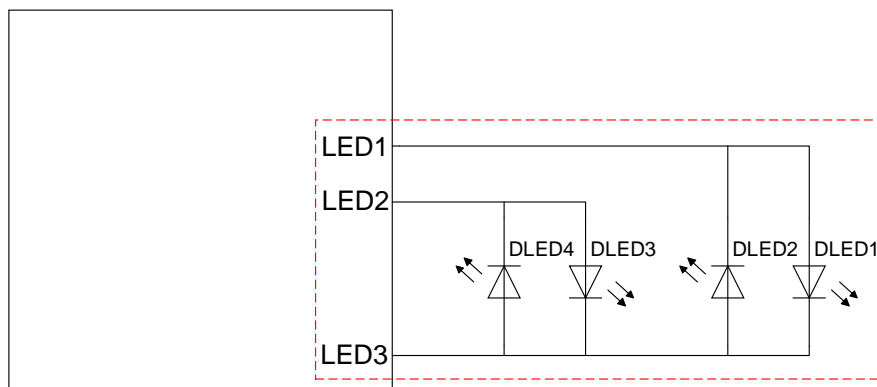

**Table 5-5 4-LED Display Mode**

Mode	Battery Level	DLED1	DLED2	DLED3	DLED4
Charge	Full	Always On	Always On	Always On	Always On
	75%-100%	Always On	Always On	Always On	Blink at 1Hz
	50%-75%	Always On	Always On	Blink at 1Hz	Off
	25%-50%	Always On	Blink at 1Hz	Off	Off
	0%-25%	Blink at 1Hz	Off	Off	Off
Discharge	75%-100%	On for 8s	On for 8s	On for 8s	On for 8s
	50%-75%	On for 8s	On for 8s	On for 8s	Off
	25%-50%	On for 8s	On for 8s	Off	Off
	5%-25%	On for 8s	Off	Off	Off
	0%-5%	Blink at 1Hz for 8s	Off	Off	Off
Earbud plug in	—	Blink at 1Hz for 1s			

## 5.7.2 LED Display Mode Configuration

**Table 5-6 LED Display Mode Register**

Register Address	Bits	R/W	Fields	Description
0x0d	[2:1]	RW	LED_I2C_MDST	LED mode status, default: 2'b00 00: 2 LED Mode 01: 3 LED Mode 10: 1 LED Mode 11: 4 LED Mode

## 5.7.3 LED Driving Capability Configuration

**Table 5-7 LED Driving Register**

Register Address	Bits	R/W	Fields	Description
0x04	[5:4]	RW	LED_DRV	LED current set, default: 2'b10 00: 0.5 mA 01: 1 mA 10: 2 mA 11: 4 mA

## 5.7.4 LED Display Control by I2C

**Table 5-8 LED Control Register**

Register Address	Bits	R/W	Fields	Description
0x0d	[0]	RW	LED_I2C_EN	I2C control enable, default: 1'b0 0: LED hardware control 1: LED I2C control
0x0d	[13:10]	RW	LED_I2C_ST	LED Status, default: 4'b0000 [13]: LED4 Status (0: Off, 1: On) [12]: LED3 Status (0: Off, 1: On) [11]: LED2 Status (0: Off, 1: On) [10]: LED1 Status (0: Off, 1: On)

## 5.8 Earbud communication

MCU supports up to 2M bidirectional communication with earbud by COML/R pin and EBL/R pin. There are two kinds of Earbud communication. One is through changing and reading COML/R pin level for communication, configure COM\_I2C\_SEL to 0 & COM\_MD1EN to 1. The other is to communicate through the I2C control register changes, configure COM\_I2C\_SEL to 1 & COM\_MD2EN to 1. The communication block diagram of COML and EBL is shown in Figure 5-10.

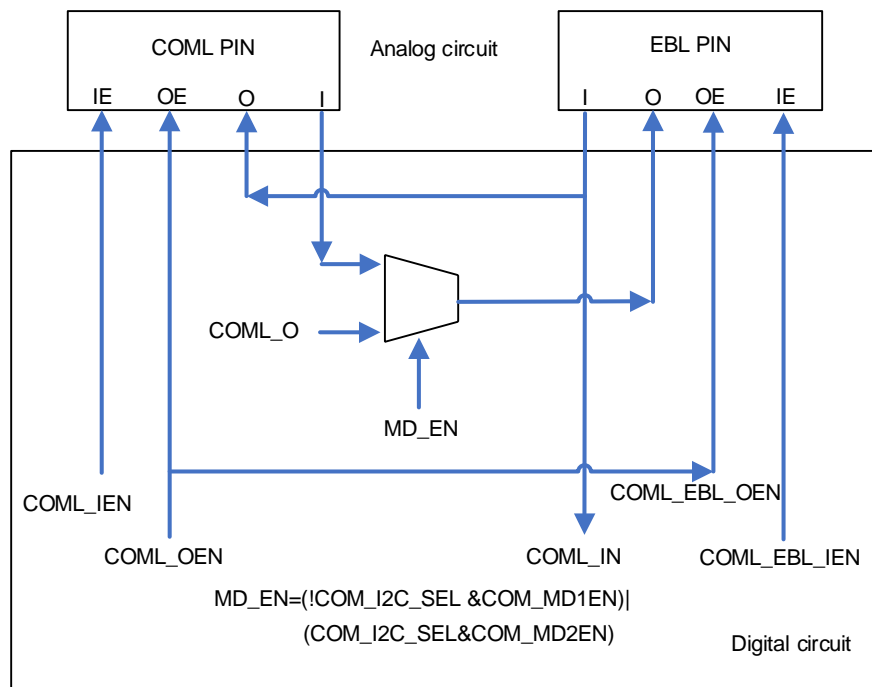
**Figure 5-10 The communication block diagram of COML and EBL**

When EBL/R is used as the output pin, the output low voltage is 0V, and the output high

voltage is VBAT or 5V. (When boost is used, the output high voltage is 5V, otherwise the output high voltage is VBAT)

When COML/R is used as the output pin, the output low voltage is 0V, and the output high voltage is VBAT.

When EBL/R or COML/R is used as the input pins, the input low voltage is  $0V - 0.35 * VCC$ , and the input high voltage is  $0.65 * VCC - 5.5V$ . The input characteristics follow Table 6-5.

## 5.9 EN and IRQ

The IRQ pin will generate an 8ms neg-edge pulse, when fault or work status are appeared. MCU can wake up the chip by giving a high voltage on EN pin.

IRQ sources include the following:

- 1) Battery charge end
- 2) Watch dog time out fault
- 3) Battery charge time out fault
- 4) Battery pre-charge time out fault
- 5) Over temperature fault (more than 150°C)
- 6) NTC Hot fault
- 7) NTC cold fault
- 8) VSYS under voltage fault
- 9) VSYS over voltage fault
- 10) USB plug in
- 11) USB pull out
- 12) Left or right earbud plug in
- 13) Left or right earbud pull out
- 14) Left or right earbud light load
- 15) Left or right earbud short/under voltage fault
- 16) VUSB over voltage fault
- 17) VBAT over voltage fault when charge the battery
- 18) VBAT under voltage fault when the battery discharge

## 5.10 Over temperature protection

If the die temperature exceeds the trip point of the thermal shutdown limit ( $T_{SD}$ ), all the circuits are disabled, and the IRQ pin is pulled low.

## 5.11 I2C interface

The I2C (inter-integrated circuit) module provides an I2C interface which is an industry standard two-line serial interface for MCU to communicate with external I2C interface. I2C bus uses two serial lines: a serial data line (SDA), and a serial clock line (SCL).

The I2C interface implements standard I2C protocol with standard-mode (up to 100 kHz) and fast-mode (up to 400 kHz). The I2C interface only supports Slave-mode. The I2C interface receive data on rising SCL and transmit data on falling SCL.

**Figure 5-11 I2C communication flow**

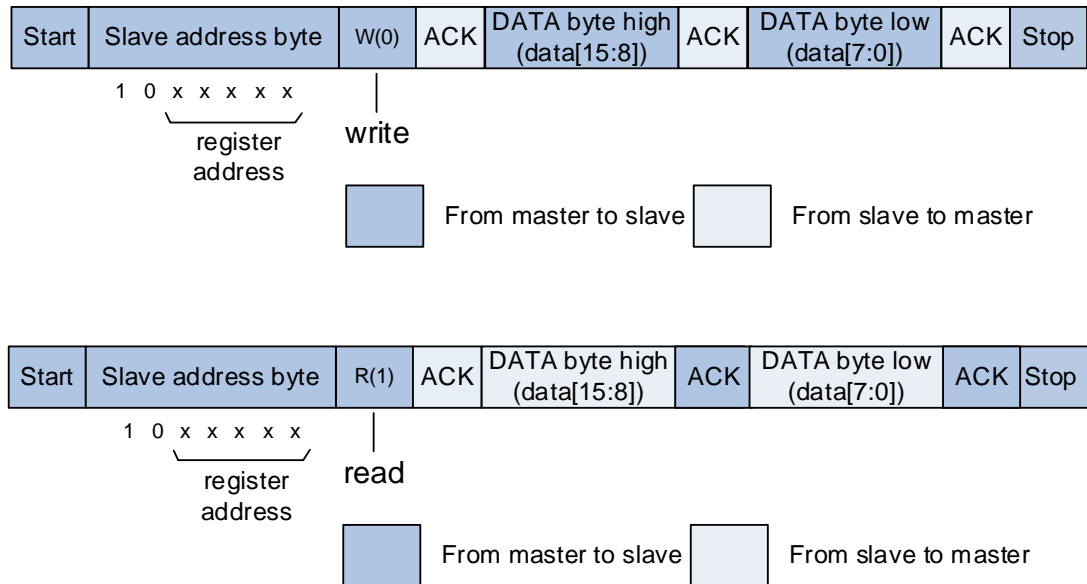

The data format is fixed:

- 8bit function (2'b10 + 5bit(register address), +1bit(1'b0-write, 1'b1-read))
- + 8bit data[15:8]
- + 8bit data[7:0].

## 5.12 Register Map

### 5.12.1 Fault Register

Address: 0b 00000

Bits	R/W	fields	default	Description
15	RW	I2C_ACK_FAULT	0b0	I2C fault Software can clear it by writing 1. 0: I2C normally 1: I2C ACK fault/clear
14	R	Reserved	0b0	Must be kept at reset value.
13	R	PCH_TO_FAULT	0b0	Pre-charge timeout fault Software can clear it by writing Control Register bit10 I2C_CLR_FAULT. 0: Pre-charge normally 1: Pre-charge timeout fault
12	R	CH_TO_FAULT	0b0	Charge timeout fault Software can clear it by writing Control Register bit10

Bits	R/W	fields	default	Description
				I2C_CLR_FAULT. 0: Charge normally 1: Charge timeout fault
11	R	WDG_FAULT	0b0	Watchdog timeout fault Software can clear it by writing Control Register bit13 WDG_CLR or writing Watchdog Register bits WDG_DATA[9:1]. 0: Watchdog normally 1: Watchdog timeout fault
10	R	VUSB_OC_FAULT	0b0	VUSB over current fault 0: VUSB current normally 1: VUSB over current fault
9	R	VUSB_OV_FAULT	0b0	VUSB over voltage fault 0: VUSB voltage normally 1: VUSB over voltage fault
8	R	EBR_UV_FAULT	0b0	EBR under voltage fault Software can clear it by writing Control Register bit10 I2C_CLR_FAULT. 0: EBR voltage normally 1: EBR under voltage fault
7	R	EBL_UV_FAULT	0b0	EBL under voltage fault Software can clear it by writing Control Register bit10 I2C_CLR_FAULT. 0: EBL voltage normally 1: EBL under voltage fault
6	R	VSYS_OV_FAULT	0b0	VSYS over voltage fault Software can clear it by writing Control Register bit10 I2C_CLR_FAULT. 0: VSYS voltage normally 1: VSYS over voltage fault
5	R	VSYS_UV_FAULT	0b0	VSYS under voltage fault Software can clear it by writing Control Register bit10 I2C_CLR_FAULT. 0: VSYS voltage normally 1: VSYS under voltage fault
4	R	NTC_HOT_FAULT	0b0	NTC_HOT fault Software can clear it by writing Control Register bit10 I2C_CLR_FAULT. 0: NTC normally 1: NTC hot fault
3	R	NTC_COLD_FAULT	0b0	NTC_COLD fault Software can clear it by writing Control Register bit10

Bits	R/W	fields	default	Description
				I2C_CLR_FAULT. 0: NTC normally 1: NTC cold fault
2	R	VBAT_OV_FAULT	0b0	VBAT over voltage fault Software can clear it by writing Control Register bit10 I2C_CLR_FAULT. 0: VBAT voltage normally 1: VBAT over voltage fault
1	R	VBAT_UV_FAULT	0b0	VBAT under voltage fault Software can clear it by writing Control Register bit10 I2C_CLR_FAULT. 0: VBAT voltage normally 1: VBAT under voltage fault
0	R	TEMP_FAULT	0b0	Over temperature fault 0: The battery temperature normally 1: The battery over temperature fault

### 5.12.2 Status Register 1

Address: 0b 00001

Bits	R/W	fields	default	Description
15	R	PCH_ENF	0b0	Pre-charge enable flag 0: Pre-charge is disabled 1: Pre-charge is enabled
14	R	VUSB_ENF	0b0	VUSB enable flag 0: VUSB is disabled 1: VUSB is enabled
13	R	VUSBOV_ENF	0b0	VUSB over voltage detection enable flag 0: VUSB over voltage detection is disabled 1: VUSB over voltage detection is enabled
12	R	VBAT_PCH_OF	0b0	VBAT pre-charge output flag 0: VBAT is higher than pre-charge threshold voltage VPCH 1: VBAT is lower than pre-charge threshold voltage VPCH
11	R	VBAT_RCH_OF	0b0	VBAT re-charge output flag 0: VBAT is higher than re-charge threshold voltage VRCH 1: VBAT is lower than re-charge threshold voltage VRCH
10	R	EBL_ENF	0b0	EBL enable flag 0: EBL is closed 1: EBL is opened
9	R	EBR_ENF	0b0	EBR enable flag 0: EBR is closed

Bits	R/W	fields	default	Description
				1: EBR is opened
8	R	Reserved	0b0	Must be kept at reset value.
7	R	USB_PLINF	0b0	USB plug in flag 0: USB is not plugged in 1: USB is plugged in
6	R	CH_ENDF	0b0	Charge end flag 0: Charge is not ended 1: Charge is ended
5	R	CCCH_ENDF	0b0	Constant current charge end flag 0: Constant current charge is not ended 1: Constant current charge is ended
4	R	EBL_PLINF	0b0	Left earbud plug in flag 0: Left earbud is not plugged in 1: Left earbud is plugged in
3	R	EBR_PLINF	0b0	Right earbud plug in flag 0: Right earbud is not plugged in 1: Right earbud is plugged in
2	R	EBL_IOFFF	0b0	Left earbud current load flag 0: Heavy load 1: Light load
1	R	EBR_IOFFF	0b0	Right earbud current load flag 0: Heavy load 1: Light load
0	R	BST_ENF	0b0	Boost enable flag 0: Boost is disabled 1: Boost is enabled

### 5.12.3 Status Register 2

Address: 0b 00010

Bits	R/W	fields	default	Description
15:8	R	Reserved	0b0	Must be kept at reset value.
7	R	EBL_UVENF	0b0	EBL under voltage detection enable flag 0: EBL under voltage detection is disabled 1: EBL under voltage detection is enabled
6	R	EBR_UVENF	0b0	EBR under voltage detection enable flag 0: EBR under voltage detection is disabled 1: EBR under voltage detection is enabled
5	R	RCHCMP_ENF	0b0	Re-charge comparator enable flag 0: Re-charge comparator is disabled 1: Re-charge comparator is enabled
4	R	VBAT_OV_ENF	0b0	VBAT over voltage detection enable flag



Bits	R/W	fields	default	Description
				0: VBAT over voltage detection is disabled 1: VBAT over voltage detection is enabled
3:2	R	Reserved	0b0	Must be kept at reset value.
1	R	PCHCMP_ENF	0b0	Pre- charge comparator enable flag 0: Pre-charge comparator is disabled 1: Pre-charge comparator is enabled
0	R	CH_ENF	0b0	Charge enable flag 0: Charge is disabled 1: Charge is enabled

### 5.12.4 Control Register

Address: 0b 00011

Bits	R/W	fields	default	Description
15	RW	Reserved	0b0	Must be kept at reset value.
14	RW	TEMPREG_EN	0b0	Temperature regulation enable 0: Enable temperature regulation 1: Disable temperature regulation
13	RW	WDG_CLR	0b0	Feed watchdog Software can clear it by writing 1 to this bit, or reset watchdog register bits WDG_DATA[9:1]. 0: Watchdog normally 1: Feed watchdog
12	R	Reserved	0b0	Must be kept at reset value.
11	RW	ADC_EN	0b0	ADC enable 0: Disable ADC 1: Enable ADC
10	RW	I2C_CLR_FAULT	0b0	I2C clear all faults 0: No effect 1: Clear all faults
9	RW	RST_ALL	0b0	Reset all chip 0: No effect 1: Reset all chip
8	RW	RST_OTHS	0b0	Reset all chip but I2C itself 0: No effect 1: Reset all chip but I2C itself
7:6	RW	ADC_CLKSEL	0b0	ADC clock selection 00: ADC clock is 2MHz 01: ADC clock is 1MHz 10: ADC clock is 500kHz 11: ADC clock is 250kHz
5	R	Reserved	0b0	Must be kept at reset value.

Bits	R/W	fields	default	Description
4	RW	BST_EN	0b0	Boost enable 0: Disable boost 1: Enable boost
3	RW	CH_EN	0b0	Charge enable 0: Disable charge 1: Enable charge
2	RW	EBL_EN	0b0	EBL switch enable 0: Close EBL 1: Open EBL
1	RW	EBR_EN	0b0	EBR switch enable 0: Close EBR 1: Open EBR
0	RW	SLP_EN	0b0	Sleep mode enable 0: Disable Sleep mode 1: Enable Sleep mode

### 5.12.5 User configure Register 1

Address: 0b 00100

Bits	R/W	fields	default	Description
15:6	R	Reserved	0b0	Must be kept at reset value.
5:4	RW	LED_DRV	0b10	LED current set 00: 0.5 mA 01: 1 mA 10: 2 mA 11: 4 mA
3:2	RW	BST_ITHSET	0b10	Boost maximum current threshold set 00: Boost maximum current threshold 1.6A 01: Boost maximum current threshold 1.8A 10: Boost maximum current threshold 2.0A 11: Boost maximum current threshold 2.2A
1:0	RW	IOFF_SET	0b10	Earbud light load current set 00: Earbud light load current is set to 90% 01: Earbud light load current is set to 95% 10: Earbud light load current is set to 100% 11: Earbud light load current is set to 105%

### 5.12.6 User configure Register 2

Address: 0b 00101

Bits	R/W	fields	default	Description
15:13	R	Reserved	0b0	Must be kept at reset value.

Bits	R/W	fields	default	Description
12:10	RW	VSYS_SET	0b100	VSYS voltage set 000: Boost output voltage 4.8V 001: Boost output voltage 4.85V 010: Boost output voltage 4.9V 011: Boost output voltage 4.95V 100: Boost output voltage 5V 101: Boost output voltage 5.05V 110: Boost output voltage 5.1V 111: Boost output voltage 5.15V
9:8	RW	VUSB_CL_SET	0b01	VUSB current limit set 00: VUSB current limit is set to 95% 01: VUSB current limit is set to 100% 10: VUSB current limit is set to 105% 11: VUSB current limit is set to 110%
7:6	RW	IPCH_SET	0b01	Pre-charge current set 00: Pre-charge current is set to 50% 01: Pre-charge current is set to 100% 10: Pre-charge current is set to 150% 11: Pre-charge current is set to 150%
5:4	RW	VPCHT_SET	0b01	Pre-charge terminate voltage set 00: Pre-charge terminate voltage is 3.0V 01: Pre-charge terminate voltage is 3.1V 10: Pre-charge terminate voltage is 3.2V 11: Pre-charge terminate voltage is 3.3V
3:2	RW	ICCCH_SET	0b0	Constant current charge current set 00: Constant current charge current is set to 100% 01: Constant current charge current is set to 75% 10: Constant current charge current is set to 50% 11: Constant current charge current is set to 25%
1:0	RW	VRCHT_SET	0b01	Re-charge threshold voltage set 00: Re-charge threshold voltage is 3.9V 01: Re-charge threshold voltage is 4.0V 10: Re-charge threshold voltage is 4.1V 11: Re-charge threshold voltage is 4.2V

### 5.12.7 User configure Register 3

Address: 0b 00110

Bits	R/W	fields	default	Description
15:7	R	Reserved	0b0	Must be kept at reset value.
6:5	RW	EBLR_ILIM_SET	0b01	EBL/EBR limit current set 00: 150mA

Bits	R/W	fields	default	Description
				01: 250mA 10: 350mA 11: 450mA
4:2	RW	VCCCHT_SET	0b0	Constant current charge terminate voltage set 000: Constant current charge terminate voltage is 4.2V 001: Constant current charge terminate voltage is 4.1V 010: Constant current charge terminate voltage is 4.3V 011: Constant current charge terminate voltage is 4.35V 100: Constant current charge terminate voltage is 4.4V 101: Constant current charge terminate voltage is 4.2V 110: Constant current charge terminate voltage is 4.2V 111: Constant current charge terminate voltage is 4.2V
1:0	RW	ICHT_SET	0b10	Charge terminate current set 00: Charge terminate current minus 10mA 01: Charge terminate current minus 5mA 10: Charge terminate current no change 11: Charge terminate current plus 5mA

### 5.12.8 Watchdog Register

Address: 0b 01011

Bits	R/W	Fields	default	Description
15:10	R	Reserved	0b0	Must be kept at reset value.
9:1	RW	WDG_DATA	0x1ff	Watchdog counter set Only set watchdog counter when WDG_EN is 0
0	RW	WDG_EN	0b0	Watchdog enable 0: Disable watchdog 1: Enable watchdog

### 5.12.9 COML/R Register

Address: 0b 01100

Bits	R/W	fields	default	Description
15	R	Reserved	0b0	Must be kept at reset value.
14	RW	COML_EBL_IEN	0b0	EBL pin input enable 0: Disable EBL pin input 1: Enable EBL pin input
13	RW	COMR_EBR_IEN	0b0	EBR pin input enable 0: Disable EBR pin input 1: Enable EBR pin input
12	RW	COML_IEN	0b0	COML pin input enable 0: Disable COML pin input

Bits	R/W	fields	default	Description
				1: Enable COML pin input
11	RW	COMR_IEN	0b0	COMR pin input enable 0: Disable COMR pin input 1: Enable COMR pin input
10	RW	COML_EBL_OEN	0b0	EBL pin output enable 0: Disable EBL pin output 1: Enable EBL pin output
9	RW	COMR_EBR_OEN	0b0	EBR pin output enable 0: Disable EBR pin output 1: Enable EBR pin output
8	RW	COM_MD2EN	0b0	Communication enable mode 2 -- I2C control 0: Disable mode 2 1: Enable mode 2
7	RW	COM_MD1EN	0b0	Communication enable mode 1 -- COML/R pin control 0: Disable mode 1 1: Enable mode 1
6	RW	COML_OEN	0b0	COML pin output enable 0: Disable COML pin output 1: Enable COML pin output
5	RW	COMR_OEN	0b0	COMR pin output enable 0: Disable COMR pin output 1: Enable COMR pin output
4	RW	COM_I2C_SEL	0b0	Communication selection 0: COML/R pin control 1: I2C control
3	R	COML_IN	0b0	COML pin input signal 0: COML pin input low 1: COML pin input high
2	R	COMR_IN	0b0	COMR pin input signal 0: COMR pin input low 1: COMR pin input high
1	RW	COML_O	0b0	COML pin output signal 0: COML pin output low 1: COML pin output high
0	RW	COMR_O	0b0	COMR pin output signal 0: COMR pin output low 1: COMR pin output high

### 5.12.10 LED Register

Address: 0b 01101

Bits	R/W	fields	default	Description
------	-----	--------	---------	-------------

Bits	R/W	fields	default	Description
15:14	R	Reserved	0b0	Must be kept at reset value.
13	RW	LED4_I2C_ST	0b0	LED4 Status 0: Off 1: On
12	RW	LED3_I2C_ST	0b0	LED3 Status 0: Off 1: On
11	RW	LED2_I2C_ST	0b0	LED2 Status 0: Off 1: On
10	RW	LED1_I2C_ST	0b0	LED1 Status 0: Off 1: On
9:3	R	Reserved	0b0	Must be kept at reset value.
2:1	RW	LED_I2C_MDST	0b0	LED mode status 00: 2 LED mode 01: 3 LED mode 10: 1 LED mode 11: 4 LED mode
0	RW	LED_I2C_EN	0b0	LED I2C control enable 0: LED Hardware control 1: LED I2C control

## 5.12.11 ADC Register

Address: 0b 01110

Bits	R/W	fields	default	Description
15:4	R	ADC_DATA	0b0	ADC measure 12 bit data.
3:1	RW	ADC_CHSEL	0b0	ADC channel select 000: Channel VBAT 001: Channel VRCH 010: Channel VSENS_EBL 011: Channel VSENS_EBR 100: Channel VCOM 101: Channel VIC 110: Channel VIR 111: Channel AVSS
0	R	Reserved	0b0	Must be kept at reset value.

## 5.12.12 DEBUG Register

Address: 0b 01111

Bits	R/W	fields	default	Description
15	RW	FIL_EN	0b1	I2C/COML/COMR PAD filter enable. 0: Filter is disabled 1: Filter is enabled
14:12	R	Reserved	0b0	Must be kept at reset value.
11:10	R/W	CH_TO_SEL	0b0	Charge status timeout time select 00: 120 minute 01: 180 minute 10: 240 minute 11: 60 minute
9	R/W	VBAT_FULL	0b0	Battery is charged fully, set by software. It will affect the LED display 0: Battery is not charged fully. LED displays normally according to battery power 1: Battery is charged fully. LED displays according to battery full charge
8:0	R	Reserved	0b0	Must be kept at reset value.

## 6 Electrical characteristics

### 6.1 Absolute maximum ratings

The maximum ratings are the limits to which the device can be subjected without permanently damaging the device. Note that the device is not guaranteed to operate properly at the maximum ratings. Exposure to the absolute maximum rating conditions for extended periods may affect device reliability.

**Table 6-1 Absolute maximum ratings**

Symbol	Parameter	Min	Max	Unit
V <sub>USB</sub>	Power supply pin from USB other 5V input	-0.3	7	V
	Power supply pin from USB other 5V input, pulsed less than 20us	-0.3	20	V
V <sub>BAT</sub>	Battery voltage	-0.3	7	V
V <sub>SYS</sub>	Output Voltage	-0.3	7	V
V <sub>CC</sub>	LDO output voltage and Internal logic voltage	-0.3	7	V
V <sub>IO</sub>	I/O pin voltage (LEDx, ISET, EN, NTC, SCL, SDA)	-0.3	7	V
V <sub>EBLR</sub>	Earbuds positive terminal voltage (EBL/EBR)	-0.3	7	V
V <sub>SW</sub>	Switching node voltage (SW)	-0.3	7	V
Thermal characteristics				
T <sub>J</sub>	Operating junction temperature	-40	150	°C
T <sub>stg</sub>	Storage temperature	-65	150	°C

### 6.2 Recommended operation conditions

**Table 6-2 Recommended operation conditions**

Symbol	Parameter	Min	Typ	Max	Unit
V <sub>USB</sub>	Power supply pin from USB other 5V input	4.4	5.0	5.5	V
V <sub>BAT</sub>	Battery voltage	2.2	4.0	4.4	V
V <sub>SYS</sub>	BOOST output Voltage	4.8	5.0	5.15	V
V <sub>CC</sub>	LDO output voltage and Internal logic voltage	2.0	3.3	3.6	V
Thermal characteristics					
T <sub>A</sub>	Operating ambient temperature	-20	—	85	°C

### 6.3 Electrical sensitivity

The device is strained in order to determine its performance in terms of electrical sensitivity. Electrostatic discharges (ESD) are applied directly to the pins of the sample.



**Table 6-3 Electrostatic Discharge characteristics**

Symbol	Parameter	Conditions	Value	Unit
$V_{ESD(HBM)}$	Electrostatic discharge voltage (human body model)	$T_A = 25\text{ }^\circ\text{C}$ ; JS-001-2017	$\pm 2000$	V
$V_{ESD(CDM)}$	Electrostatic discharge voltage (charge device model)	$T_A = 25\text{ }^\circ\text{C}$ ; JS-002-2018	$\pm 1000$	V

## 6.4 Power supplies voltages and currents

**Table 6-4 Power supplies voltages and currents**

Symbol	Parameter	Conditions	Min	Typ	Max	Unit
$I_Q$	Sleep mode quiescent current	$V_{BAT} = 5\text{ V}$ , $T_A = 25\text{ }^\circ\text{C}$	—	—	5.0	$\mu\text{A}$
		$V_{BAT} = 5\text{ V}$ , $T_A = 85\text{ }^\circ\text{C}$	—	—	TBD	$\mu\text{A}$
$t_{ON}$	Turn-on time	$V_{USB} > V_{UVLO}$ to outputs ready	5.0	—	—	ms
$V_{CC}$	VCC regulator voltage	$I_{VCC} = 0$ to 50 mA ( $V_{BAT} > 3.4\text{ V}$ )	3.1	3.3	3.5	V

## 6.5 Logic input characteristics

**Table 6-5 Logic input characteristics**

Symbol	Parameter	Conditions	Min	Typ	Max	Unit
$V_{IL}$	Input logic low voltage	—	0	—	$0.35 * V_{CC}$	V
$V_{IH}$	Input logic high voltage	—	$0.65 * V_{CC}$	—	5.5	V
$V_{HYS}$	Input logic hysteresis	—	100	—	—	mV

## 6.6 Open drain outputs characteristics

Open drain output pins include **SCL**, **SDA**, **IRQ**.

**Table 6-6 Open drain output characteristics**

Symbol	Parameter	Conditions	Min	Typ	Max	Unit
$V_{OL}$	Output logic low voltage	$I_O = 5\text{ mA}$	—	—	0.1	V
$I_{OZ}$	Output high impedance leakage	$V_O = V_{BAT}$	-2	—	2	$\mu\text{A}$

## 6.7 NTC characteristics

**Table 6-7 NTC characteristics**

Symbol	Parameter	Conditions	Min	Typ	Max	Unit
$V_{TL}$	Low Temperature threshold voltage	—	—	$0.6 * V_{SYS}$	—	V
$V_{TH}$	High Temperature threshold voltage	—	—	$0.3 * V_{SYS}$	—	V
$V_{offset}$	Offset Voltage	—	—	—	5	mV

## 6.8 Switching charger characteristics

**Table 6-8 Charger characteristics**

Symbol	Parameter	Conditions	Min	Typ	Max	Unit
V <sub>CVCH</sub>	CV Charge voltage	Programmable	4.1	4.2	4.4	V
	CV Charge voltage precision	—	—	0.5	—	%
I <sub>CCCH</sub>	CC Charge current	R <sub>CCCH</sub> = 20 K $\Omega$	—	0.5	—	A
I <sub>PCH</sub>	Pre-Charge current	R <sub>CCCH</sub> = 20 K $\Omega$	40	50	60	mA
I <sub>TER</sub>	Charge terminate current	—	I <sub>PCH</sub> + 10			mA
V <sub>PCH</sub>	Pre-Charge to CC charge transition	Programmable	—	3.0	—	V
V <sub>PCHHYS</sub>	Pre-Charge hysteresis voltage	—	—	200	—	mV
V <sub>RCH</sub>	Re-Charge threshold	—	—	4	—	V
V <sub>RCHHYS</sub>	Re-Charge hysteresis voltage	—	—	200	—	mV

**Figure 6-1 Constant current charging efficiency**

Figure 6-2 Constant current charging chip case temperature



## 6.9 Boost converter characteristics

Table 6-9 Boost converter characteristics

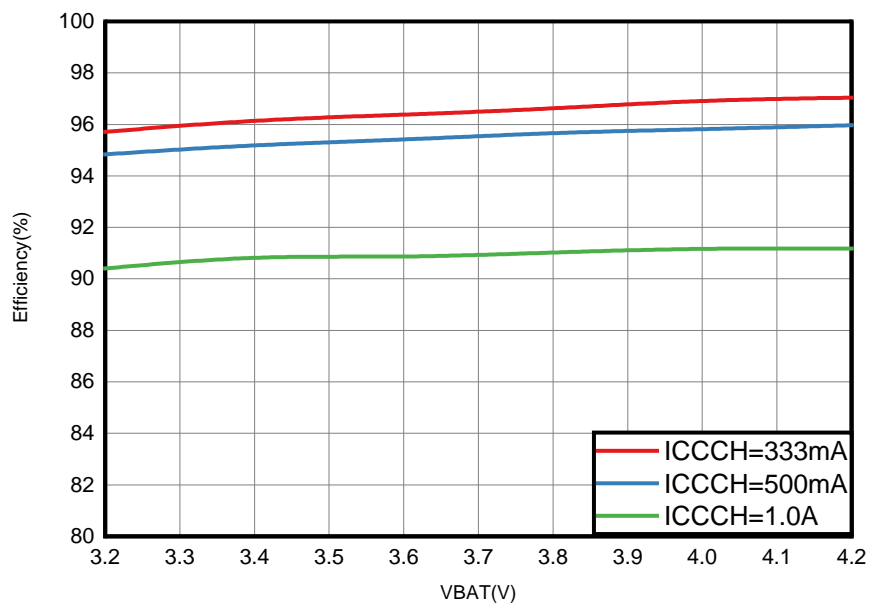
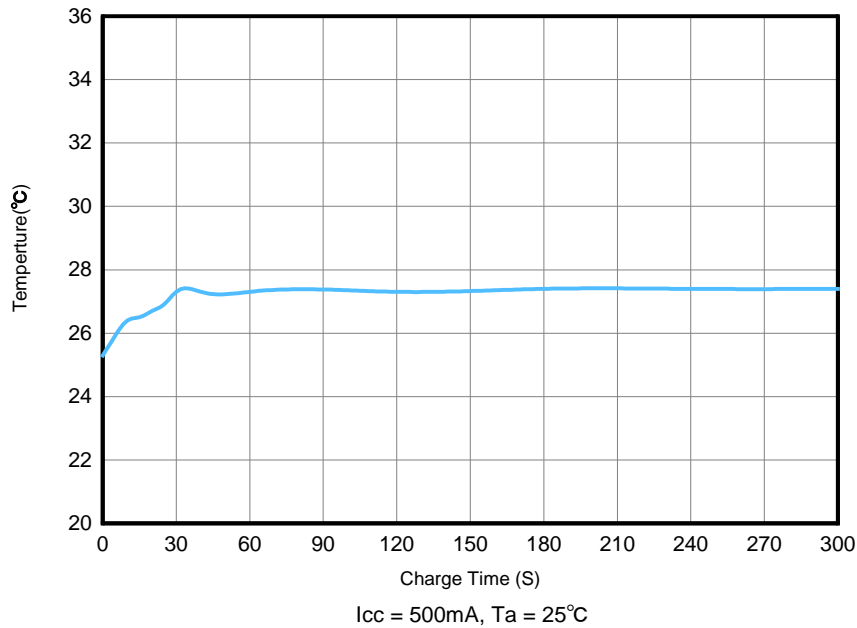
Symbol	Parameter	Conditions	Min	Typ	Max	Unit
$V_{BAT}$	Operation battery voltage	—	3.0	3.7	4.5	V
$V_{BATLOW}$	Minimum battery	$I_{SYS} = 600\text{ mA}$	2.9	—	—	V
$I_{BAT}$	Boost operation current	$V_{BAT} = 3.7\text{ V}$	—	4.0	6.0	mA
$V_{SYS}$	Output voltage	$I_{SYS} = 0\text{ mA}$	4.90	5.05	5.15	V
		$I_{SYS} = 600\text{ mA}$	4.80	5.00	5.15	V
$\Delta V_{SYS}$	Output ripple	—	—	100	—	mV
$I_{SYS}$	Output current	—	—	—	600	mA
$R_{HS}$	High Side PMOS on resistance	$V_{CC} = 3.3\text{ V}$ , $T_A = 25^\circ\text{C}$	—	150	—	m $\Omega$
$R_{LS}$	Low Side NMOS on resistance	$V_{CC} = 3.3\text{ V}$ , $T_A = 25^\circ\text{C}$	—	150	—	m $\Omega$
$I_{LIM}$	Peak current limit	$V_{BAT} = 3.7\text{ V}$ , $T_A = 25^\circ\text{C}$	—	2.0	—	A
	Peak current limit during startup	$V_{BAT} = 3.7\text{ V}$ , $T_A = 25^\circ\text{C}$	—	0.6	—	A
$f_{sw}$	Switching frequency	—	0.9	1.0	1.1	MHz
$I_{sw}$	Switching node leakage	—	—	—	1.0	$\mu\text{A}$
$D_{max}$	Maximum Duty Cycle	—	90	—	—	%

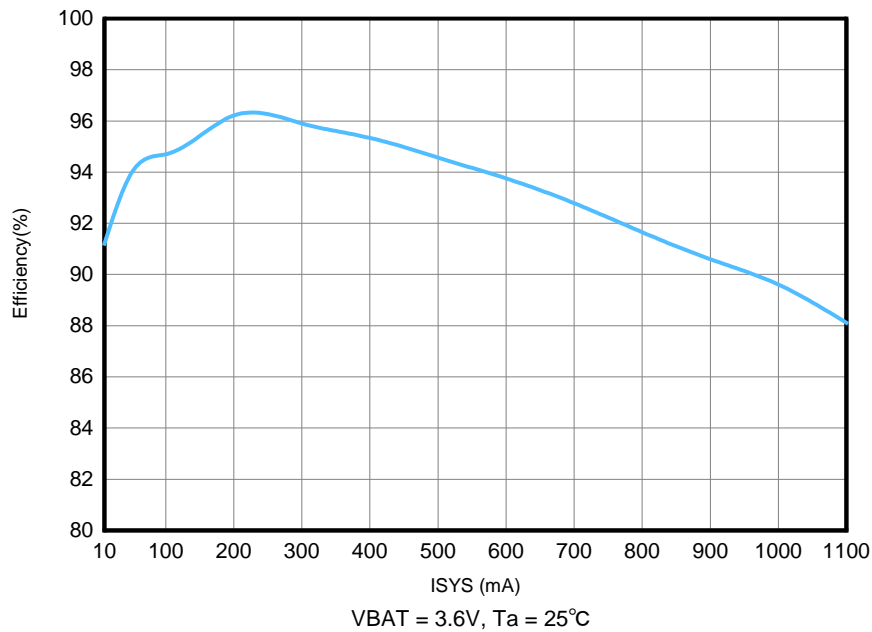
**Figure 6-3 BOOST conversion efficiency**

## 6.10 ADC characteristics

**Table 6-10 ADC characteristics**

Symbol	Parameter	Conditions	Min	Typ	Max	Unit
V <sub>BAT</sub>	Operation battery voltage	—	3.0	3.7	4.5	V
f <sub>ADC</sub>	ADC clock frequency	—	—	2.0	—	MHz
f <sub>s</sub>	Sampling rate	—	—	0.08	—	MSPS
V <sub>REFP</sub>	Positive Reference Voltage	—	2.49	2.5	2.51	V
V <sub>REFN</sub>	Negative Reference Voltage	—	—	0	—	V
t <sub>s</sub>	Sampling time	f <sub>ADC</sub> = 2 MHz	—	6	—	us
			—	12	—	1/ f <sub>ADC</sub>
t <sub>CONV</sub>	Total conversion time(including sampling time)	—	—	25	—	1/ f <sub>ADC</sub>
t <sub>STAB</sub>	Power-up time	—	—	—	1	us
ENOB	Effective number of bits	f <sub>ADC</sub> = 2 MHz	—	10.3	—	bits
SNDR	Signal-to-noise and distortion ratio	Input Frequency = 2 kHz Temperature = 25 °C	—	63.8	—	dB
SNR	Signal-to-noise ratio		—	64.5	—	
THD	Total harmonic distortion		—	-71.0	—	
Offset	Offset error	f <sub>ADC</sub> = 2 MHz	±1	—	—	LSB
DNL	Differential linearity error		±1.5	—	—	

## 6.11 Timing characteristics

**Table 6-11 Timing characteristics**

Symbol	Parameter	Conditions	Min	Typ	Max	Unit
$t_{PCH\_FAULT}$	Pre-charge fault time	—	—	30	—	min
$t_{CH\_TO}$	Charge Time Out	—	—	180	—	min

## 6.12 Earbud Output Switch characteristics

**Table 6-12 Earbud output switch characteristics**

Symbol	Parameter	Conditions	Min	Typ	Max	Unit
$I_{LIM}$	EBL/EBR output current Limit (Default)	$V_{BAT} = 3.0 \sim 4.2 V$	—	250	—	mA
$V_{SHORT}$	Short protect voltage	—	—	4.3	—	V
$R_{switch}$	Switch resistance	$V_{SYS} = 5 V$	—	400	—	m $\Omega$
$I_{DET\_EAR}$	Earbud detected current threshold	—	5	—	—	$\mu A$

## 6.13 I2C characteristics

**Table 6-13 I2C characteristics**

Symbol	Parameter	Conditions	Standard mode		Fast mode		Unit
			Min	Max	Min	Max	
$t_{SCL(H)}$	SCL clock high time	—	4.0	—	0.6	—	$\mu s$
$t_{SCL(L)}$	SCL clock low time	—	4.7	—	1.3	—	$\mu s$
$t_{su(SDA)}$	SDA setup time	—	250	—	100	—	ns
$t_h(SDA)$	SDA data hold time	—	0	3450	0	900	ns
$t_r(SDA/SCL)$	SDA and SCL rise time	—	—	1000	—	300	ns
$t_f(SDA/SCL)$	SDA and SCL fall time	—	—	300	3	300	ns
$t_h(STA)$	Start condition hold time	—	4.0	—	0.6	—	$\mu s$

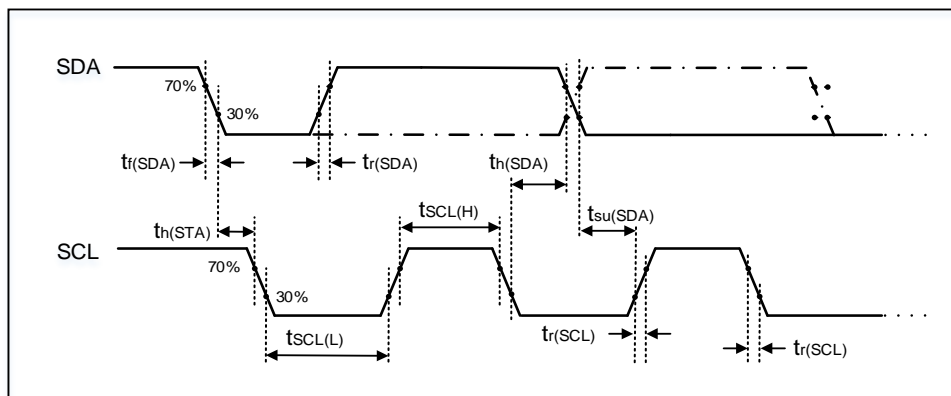
**Figure 6-4 I2C bus timing diagram**

## 6.14 Protection features

Protection features include over current protection, under voltage, over voltage and thermal shutdown.

**Table 6-14 Protection features characteristics**

Symbol	Parameter	Conditions	Min	Typ	Max	Unit
<b>V<sub>USB</sub> Switch</b>						
V <sub>USB_UVP</sub>	V <sub>USB</sub> under voltage Protection Threshold	V <sub>USB</sub> falling	—	4.3	—	V
V <sub>USB_OVP</sub>	V <sub>USB</sub> over voltage Protection Threshold	V <sub>USB</sub> rising	—	5.6	—	V
I <sub>USB_Limit</sub>	V <sub>USB</sub> input current limit	—	—	0.5 + I <sub>CCCH</sub>	—	A
V <sub>SYS_short</sub>	V <sub>SYS</sub> short voltage Protection Threshold	V <sub>SYS</sub> falling	—	4.0	—	V
<b>Charge</b>						
V <sub>BAT_OVP</sub>	V <sub>BAT</sub> over voltage Protection Threshold	VCCCHT_SET = 000	—	4.3	—	V
		VCCCHT_SET = 001	—	4.2	—	
		VCCCHT_SET = 010	—	4.4	—	
		VCCCHT_SET = 011	—	4.45	—	
		VCCCHT_SET = 100	—	4.5	—	
		VCCCHT_SET = 101	—	4.3	—	
		VCCCHT_SET = 110	—	4.3	—	
V <sub>SYS_DPM</sub>	V <sub>SYS</sub> voltage regulation limit	—	—	4.6	—	V
<b>Boost</b>						
V <sub>BAT_UVP</sub>	V <sub>BAT</sub> under voltage Protection Threshold	V <sub>BAT</sub> Falling	—	2.8	—	V
V <sub>BATUVP_HSY</sub>	V <sub>BAT</sub> under voltage Protection hysteresis	—	—	0.1	—	V
V <sub>SYS_short</sub>	V <sub>SYS</sub> short Protection Threshold	—	—	4.3	—	V
V <sub>SYS_UVP</sub>	V <sub>SYS</sub> over voltage Protection Threshold	—	—	5.5	—	V
<b>Earbud Output Switch</b>						
I <sub>LIM</sub>	EBL/EBR output current Limit	EBLR_ILIM_SET = 00	—	150	—	mA
		EBLR_ILIM_SET = 01	—	250	—	mA
		EBLR_ILIM_SET = 10	—	350	—	mA
		EBLR_ILIM_SET = 11	—	450	—	mA
I <sub>close</sub>	EBL/EBR light load Protection current	R <sub>close</sub> = 50 KΩ	—	10	—	mA
V <sub>short</sub>	EBL/EBR short	—	—	4.3	—	V

Symbol	Parameter	Conditions	Min	Typ	Max	Unit
	Protection Threshold					
<b>Temperature</b>						
T <sub>OT</sub>	Thermal shutdown temperature	Die temperature, T <sub>J</sub>	—	150	—	°C
T <sub>HYS</sub>	Thermal hysteresis	Die temperature, T <sub>J</sub>	—	20	—	°C

## 7 Typical application circuit

Figure 7-1 Typical GD30WS8805x application circuit

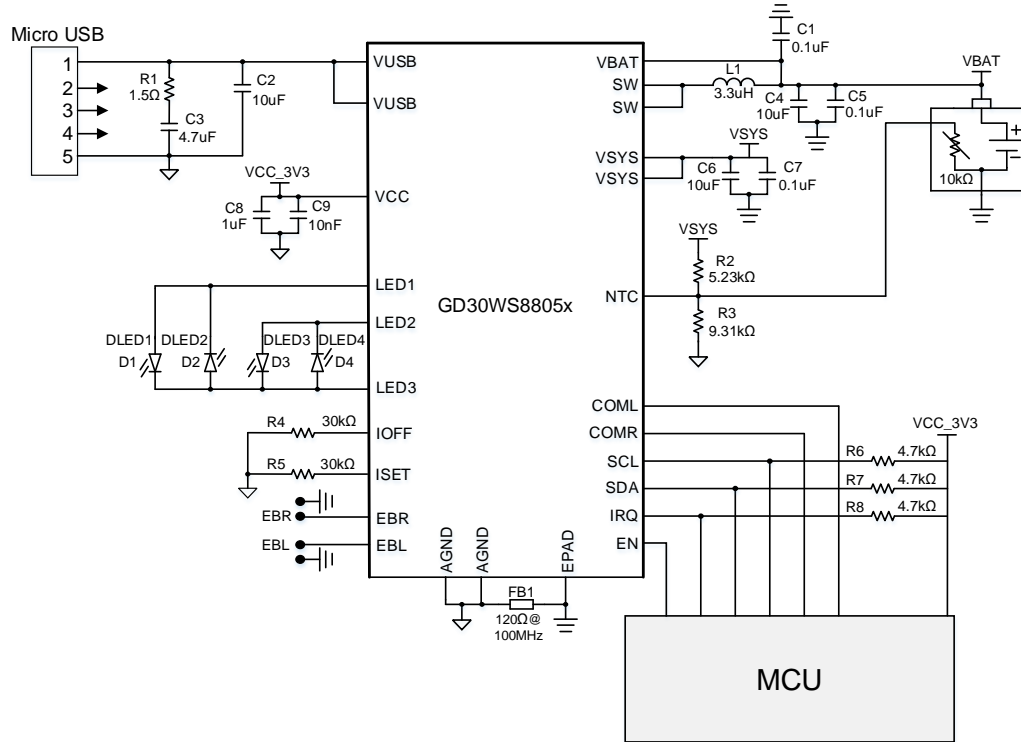



## 8 Layout guideline

Figure 8-1 Typical GD30WS8805x layout guideline

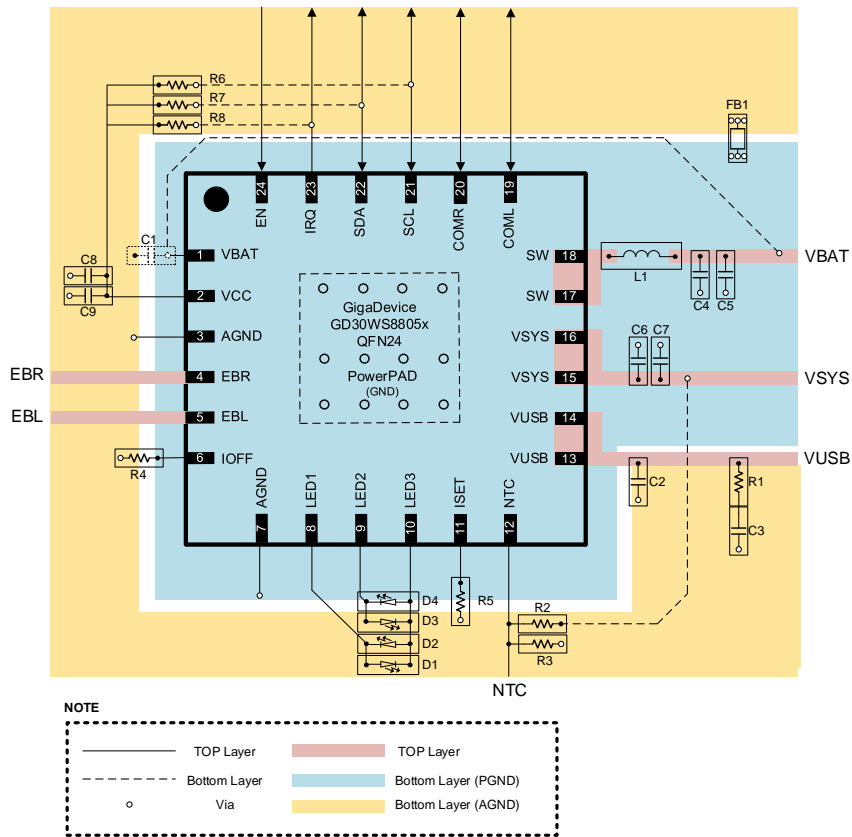

**Notes:**

1. The VBAT C1 bypass capacitor should be connected to AGND to ensure the stability of the analog loop. The VBAT C4 and C5 bypass capacitors should be connected to PGND to ensure the stability of the power loop.
2. The SW L1 inductor should be as close to the pin as possible to reduce parasitic parameters.
3. The VSYS C6 and C7 bypass capacitor should be as close to the pin as possible to ensure the stability of the output power supply.

## 9 Package information

### 9.1 QFN24 package information

Figure 9-1 QFN24 package outline

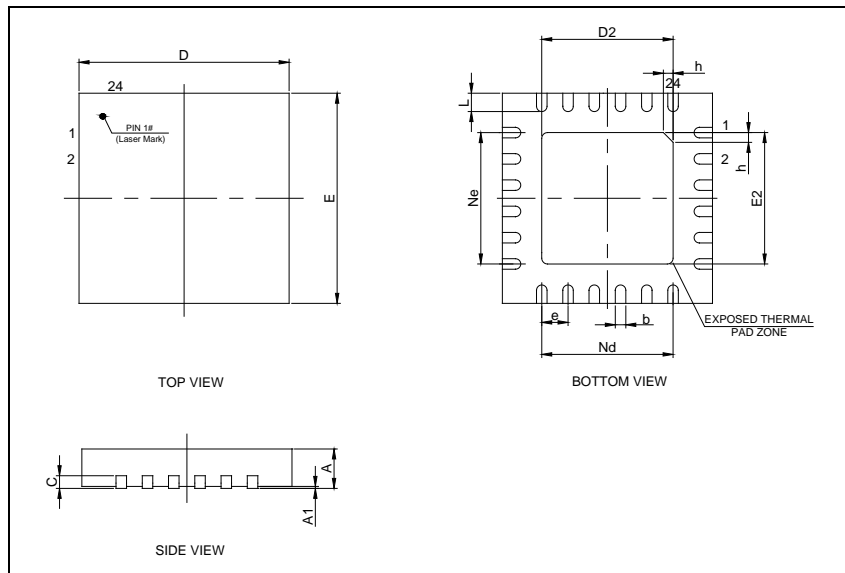
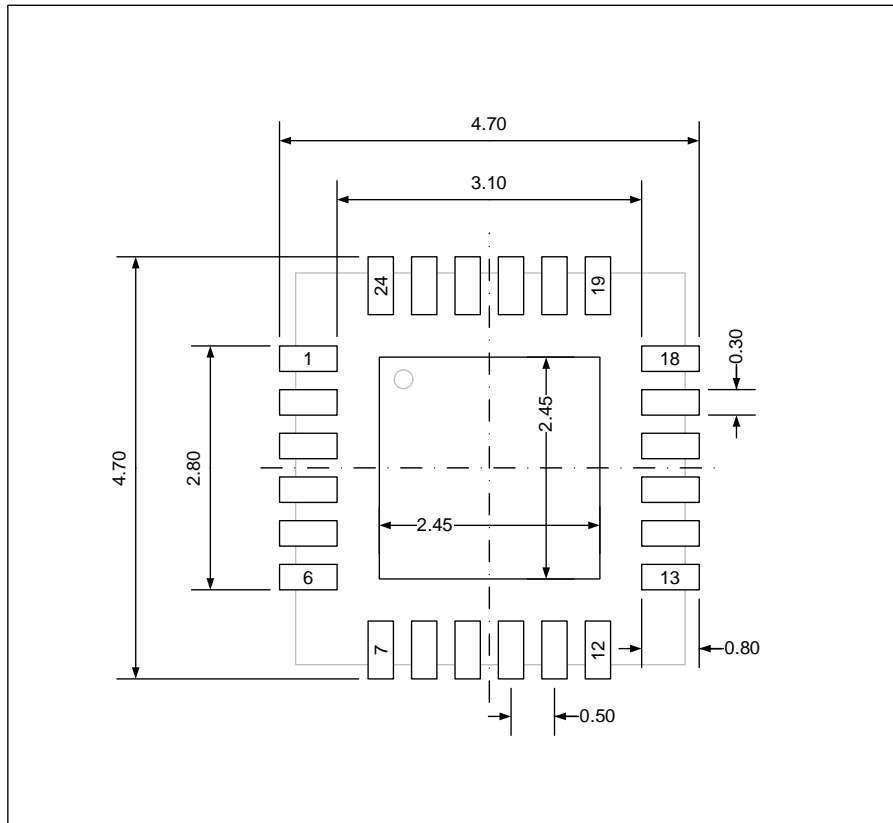

Table 9-1 QFN24 dimensions

Symbol	Min	Typ	Max
A	0.70	0.75	0.80
A1	—	0.02	0.05
b	0.18	0.25	0.30
c	0.18	0.20	0.25
D	3.90	4.00	4.10
D2	2.40	2.50	2.60
E	3.90	4.00	4.10
E2	2.40	2.50	2.60
e	—	0.50	—
h	0.30	0.35	0.40
L	0.35	0.40	0.45
Nd	—	2.50	—
Ne	—	2.50	—

(Original dimensions are in millimeters)

Figure 9-2 QFN24 recommended footprint



(All dimensions are in millimeters)

## 9.2 Thermal characteristics

Thermal resistance is used to characterize the thermal performance of the package device, which is represented by the Greek letter “ $\Theta$ ”. For semiconductor devices, thermal resistance represents the steady-state temperature rise of the chip junction due to the heat dissipated on the chip surface.

$\Theta_{JA}$ : Thermal resistance, junction-to-ambient.

$\Theta_{JB}$ : Thermal resistance, junction-to-board.

$\Theta_{JC}$ : Thermal resistance, junction-to-case.

$\Psi_{JB}$ : Thermal characterization parameter, junction-to-board.

$\Psi_{JT}$ : Thermal characterization parameter, junction-to-top center.

$$\Theta_{JA} = (T_J - T_A)/P_D$$

$$\Theta_{JB} = (T_J - T_B)/P_D$$

$$\Theta_{JC} = (T_J - T_C)/P_D$$

Where,  $T_J$  = Junction temperature.

$T_A$  = Ambient temperature

$T_B$  = Board temperature

$T_C$  = Case temperature which is monitoring on package surface

$P_D$  = Total power dissipation

$\Theta_{JA}$  represents the resistance of the heat flows from the heating junction to ambient air. It is an indicator of package heat dissipation capability. Lower  $\Theta_{JA}$  can be considerate as better overall thermal performance.  $\Theta_{JA}$  is generally used to estimate junction temperature.

$\Theta_{JB}$  is used to measure the heat flow resistance between the chip surface and the PCB board.

$\Theta_{JC}$  represents the thermal resistance between the chip surface and the package top case.

$\Theta_{JC}$  is mainly used to estimate the heat dissipation of the system (using heat sink or other heat dissipation methods outside the device package).

**Table 9-2 Package thermal characteristics<sup>(1)</sup>**

Symbol	Condition	Package	Value	Unit
$\Theta_{JA}$	Natural convection, 2S2P PCB	QFN24	47.51	°C/W
$\Theta_{JB}$	Cold plate, 2S2P PCB	QFN24	14.9	°C/W
$\Theta_{JC}$	Cold plate, 2S2P PCB	QFN24	20.99	°C/W
$\Psi_{JB}$	Natural convection, 2S2P PCB	QFN24	15.05	°C/W
$\Psi_{JT}$	Natural convection, 2S2P PCB	QFN24	0.86	°C/W

(1) Thermal characteristics are based on simulation, and meet JEDEC specification.

## 10 Ordering information

Table 10-1 Part ordering code for GD30WS8805x devices

Ordering Code	Package	Package Type	Packing Type	MOQ	Temperature Operating Range
GD30WS8805EU	QFN24(4X4)	Green	Tray	2940	Industrial -20°C to +85°C

## 11 Revision history

Table 11-1 Revision history

Revision No.	Description	Date
1.0	Initial Release	Mar.11, 2022
1.1	1. Section 4.1 Part Order Code is modified to Part Number. 2. The Package description in section 4.1 is modified to QFN24(4X4). 3. Chapter 10 <i>Ordering information</i> added information on Packing Type(Tray) and MOQ(2940).	Jun.08, 2022