



Genio 350 Evaluation Kit

Hardware User Guide

Version: 1.0
Release date: 2022-02-11

Use of this document and any information contained therein is subject to the terms and conditions set forth in [Exhibit 1](#). This document is subject to change without notice.



Version History

Version	Date	Author	Description
1.0	2022-02-11	MTK	First Release

Table of Contents

1	Overview	5
1.1	General Information	5
1.2	Architecture and Block Diagram.....	5
1.3	Feature Summary	6
2	Introduction	7
2.1	CPU (MT8365)	8
2.2	Power Management IC (MT6357)	8
2.3	DRAM (Micron MT53E768M32D4DT-053)	8
2.4	eMMC Storage (SanDisk/Western Digital SDINBDA4_64G)	8
2.5	M.2 Wi-Fi/Bluetooth Module (AzureWave AW-CB451NF)	9
2.6	Optional On-Board WiFi Chip (MT6631)	9
3	Interfaces and Connectors	10
3.1	Genio 350-EVK I/O Connectors	10
3.2	System Power Paths	111
3.3	I/O Interface	12
3.4	MicroSD Slot.....	14
3.5	Power and Function Key Interface	14
3.6	USB Device	14
3.7	USB Host.....	14
3.8	Audio Interface (Earphone and Line Out).....	14
3.9	Microphones	15
3.10	MIPI DSI Interface.....	15
3.11	MIPI CSI Interface	15
3.12	Ethernet MII and RMII Interfaces	15
3.13	How to Switch between HDMI and Ethernet Interfaces	16
3.14	HDMI Port.....	17
3.15	Pin Mux for Other Interfaces.....	17
3.16	On-Board Antenna	18
3.17	LCM FPC Installation.....	19
3.18	How to Power Up The System	19
3.19	How to flash Image to the board.....	19
3.20	Debug	20
4	Camera Sub-Board	21
4.1	Feature	21
4.2	Camera Sub-Board Block Diagram.....	21
4.3	How to Configure the MIPI CSI Path.....	22
5	Reference Documents.....	23
5.1	Contains in The Box	23
5.2	PCBA Version	23
5.3	Disclaimer	23



5.4 Power Distribution 24

1 Overview

1.1 General Information

Genio 350-EVK is an evaluation kit of MediaTek Genio 350 platform, integrated with WiFi, Bluetooth, FM, and GPS, is a high performance IoT platform with rich features.

1.2 Architecture and Block Diagram

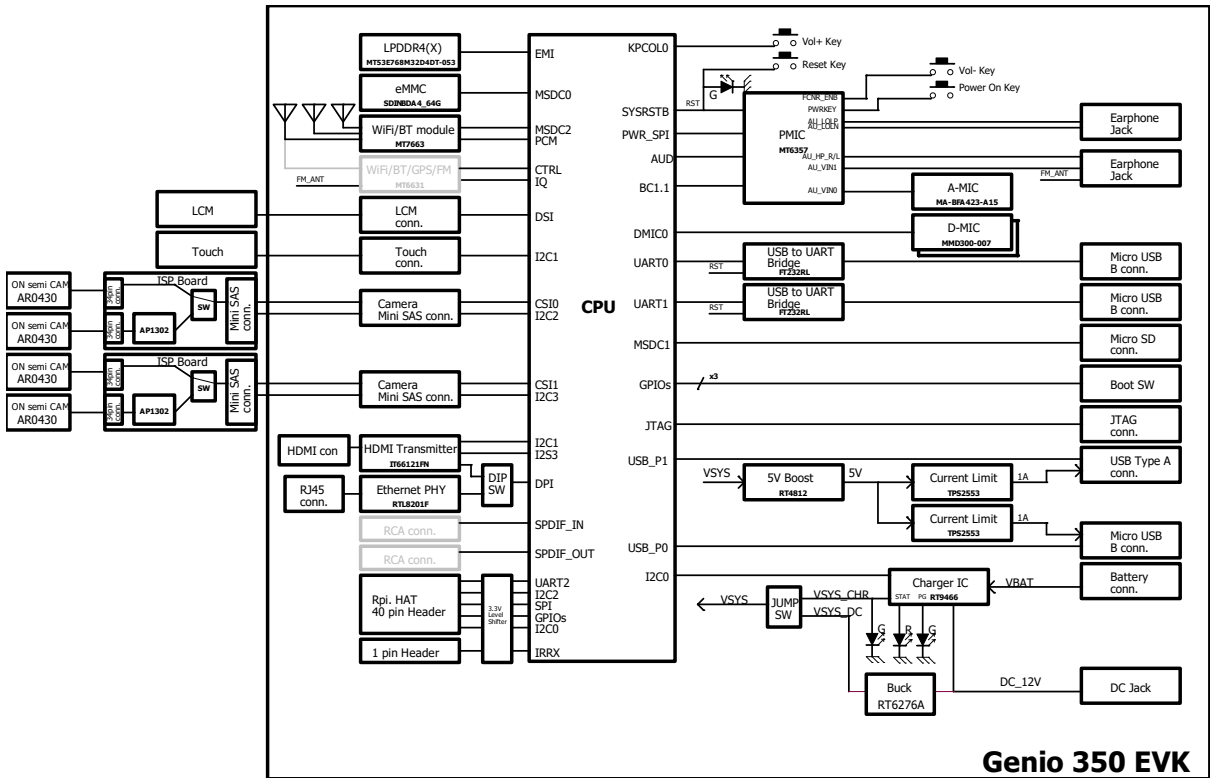

Figure 1-1 Genio 350 Evaluation Kit System Block Diagram

1.3 Feature Summary

- MediaTek Genio 350 CPU (MT8365)
- MediaTek PMIC (MT6357)
- 3GB LPDDR4 RAM x 1 (Micron MT53E768M32D4DT-053)
- 64GB eMMC x 1 (SanDisk/Western Digital SDINBDA4_64G)
- 2.0mm DC Jack x 1 (for 12V DC Input)
- Micro SD Card Slot x 1
- Push Button x 4 (Power, Reset, Volume-Up and Volume-Down)
- LED x 4 (Power, Reset, Charging Power Good and Charging Status)
- 4-Lane DSI x 1
- HDMI x 1
- 10/100 Ethernet x 1 (Shared with DIP Signal)
- USB Device Port x 1 (Micro USB Connector)
- USB Host Port x 1 (Type-A USB Connector)
- 3.5mm Earphone Jack x 1 (with Microphone Input)
- 3.5mm Line Out Audio Jack x 1
- Analog Microphone x 1
- Digital Microphone x 2
- UART Port x 2 for Trace Log with USB to UART Bridge IC (Micro USB Connector x 2)
- I2C Capacitive Touch Pad
- 4-Data Lane CSI x 2 (SAS SFF-8087 Connector)
- M.2 Slot x 1 (for AzureWave AW-CB451NF WiFi Module)
- 40-Pin 2.54mm Pin Header x 1 (for Raspberry Pi like I/O Interface)
- 3-bit DIP Switch for Boot ID
- 2-Pin 2.54mm Jumper (for IrDA Receiver)

2 Introduction

Genio 350-EVK integrates MediaTek MT8365 processor, LPDDR4 memory, eMMC, power Management IC (MT6357), and M.2 WiFi Module. The package contains a MIPI DSI LCD display, two camera sub-boards and one HDMI connector.



Figure 2-1 Genio 350-EVK System Setup

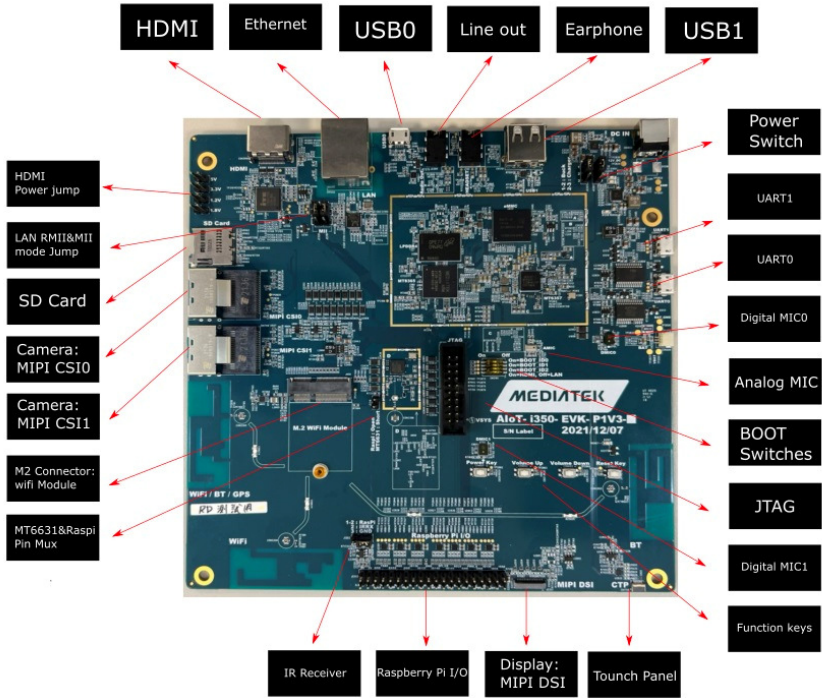

Figure 2-2 Genio 350-EVK Board overview

2.1 CPU (MT8365)

MediaTek Genio 350 processor integrates multi-core ARM® Cortex-A53 MPCore equipped with the NEON engine offers processing power necessary to support the latest OpenOs along with its demanding applications such as web browsing, email, GPS navigation, and games.

The features of the Genio 350 processor (MT8365) include the following:

- Quad-Core ARM Cortex-A53 MPCore Operating at 2.0GHz
- 32KB L1 I-Cache and 32KB L1 D-Cache
- 512KB L2 Cache
- NEON Multimedia Processing Engine
- ARM TrustZone Security
- DVFS Technology with Adaptive Operating Voltage from 0.65V to 1.025V
- Tensilica VP6 Core inside
- VFGBA-633

2.2 Power Management IC (MT6357)

- MediaTek MT6357 power management IC is a programmable power management IC that integrates 5 buck converters and 29 LDOs to provide all power rails required by SoC and peripherals.
- MT6357 adopts the SPI interface and two SRCLKEN control pins to control buck converters, LDOs, and various drivers; it provides enhanced safety control and protocol for handshaking with the processor (MT8365).
- For system management, it provides the following features,
 - 5 Buck Converters
 - 29 LDOs
 - Support Software Shutdown or Hardware Power Off
 - 26MHz External Crystal for System Clock
 - 32.768KHz RTC Oscillator for System Timing
 - Watchdog Reset
 - Over-current and Thermal Overload Protection
 - OVP, UVLO Function
 - VFBGA-209 Package

2.3 DRAM (Micron MT53E768M32D4DT-053)

Genio 350-EVK is embedded a 3GB LPDDR4 memory with the following features,

- Dual Channels with 16-bit Data Bus Width
- Up to 3200MHz Memory Clock
- Supports self-refresh/ partial self-refresh mode
- Supports dual-rank memory device
- Advanced bandwidth arbitration control

2.4 eMMC Storage (SanDisk/Western Digital SDINBDA4_64G)

- A 32GB eMMC 5.0 SanDisk (Wester Digital) SDINBDA4_64G is used for code and data storage, via MSDC0 interface of the Genio 350 processor (MT8365) with 8-bit width data bus.

2.5 M.2 Wi-Fi/Bluetooth Module (AzureWave AW-CB451NF)

MediaTek MT7663 is in AzureWave AW-CB451NF M.2 Module. It supports following features.

- M.2 2230 WiFi Module with Key-E
- MediaTek MT7663 WiFi Chip
- SDIO 3.0 Interface
- WiFi 802.11 a/b/g/n/ac
- Dual Band 2T/2R MIMO
- Bluetooth 5.0
- Security WFA WPA/WPA2 Personal, WPS 2.0, WAPI
- Integrated LNA, PA and T/R Switch
- I2S Audio Interface

2.6 Optional On-Board WiFi Chip (MT6631)

An optional on-board MediaTek MT6631 is available in development stage, supports WiFi, Bluetooth, GPS and FM.

- Dual-Band (2.4 GHz and 5 GHz) Single Stream 802.11 a/b/g/n/ac RF, 20/40/80 MHz Bandwidth
- Supports Worldwide Wi-Fi 5G Channels including new band in US and China (5,925 MHz), and Bluetooth FDD Operation
- Bluetooth Specification V2.1+EDR, 3.0+HS and V4.1+HS Compliant
- Support FM Frequency 65 ~ 108 MHz with 50 kHz per Step
- Supports FM RDS/RBDS
- FM Digital Stereo Modulator/Demodulator
- GPS, Galileo, Glonass, and Beidou
- Simultaneous Reception of GPS + Glonass + Beidou/Galileo for More Accurate Positioning

3 Interface and Connectors

3.1 Genio 350-EVK I/O Connectors

DC Jack	CN1403	12V DC Input
System Power Indicator	D1206	Green
Reset Indicator	D1207	Green
System Power Indicator	D1001	Green
Charging Status Indicator	D1	Red
Power On Button	CON001	
Volume-Up Button	CON002	
Volume-Down Button	CON003	
Reset Button	CON004	
USB Device	CON1	ADB Debug Port
USB Host	CN1701	
UART0	CON461	CPU Log
UART1	CON462	DSP Log
Micro SD Card Slot	CN460	
DSI	J2321	LCM
I2C1	CN1709	Touch Pad
CSI0	CN301	Camera 0 Sub-Board
CSI1	CN170	Camera 1 Sub-Board
HDMI	CON3000	HDMI Type-A Connector
Ethernet	CN1502	10/100Base-T
M.2 Slot	J600	WiFi Module
IrDA Receiver	J1303	
Raspberry Pi like I/O	J2303	
JTAG	J2305	
Earphone Jack	J700	
Line Out	J2304	
Battery Connector	CON200	
Analog Microphone	U700	
Digital Microphone 0	U701	
Digital Microphone 1	U702	

Table 3-1 Main Board Connectors

3.2 System Power Paths

There are two power supply paths for the system. One is through a buck converter (Richtek RT6276A), which convert 12V (DC Jack) to 4.2V (VSYS). This path supports those applications without Li-Polymer batteries.

The other is through a battery charger IC (Richtek RT9466). This path supports those applications with Li-Polymer batteries.

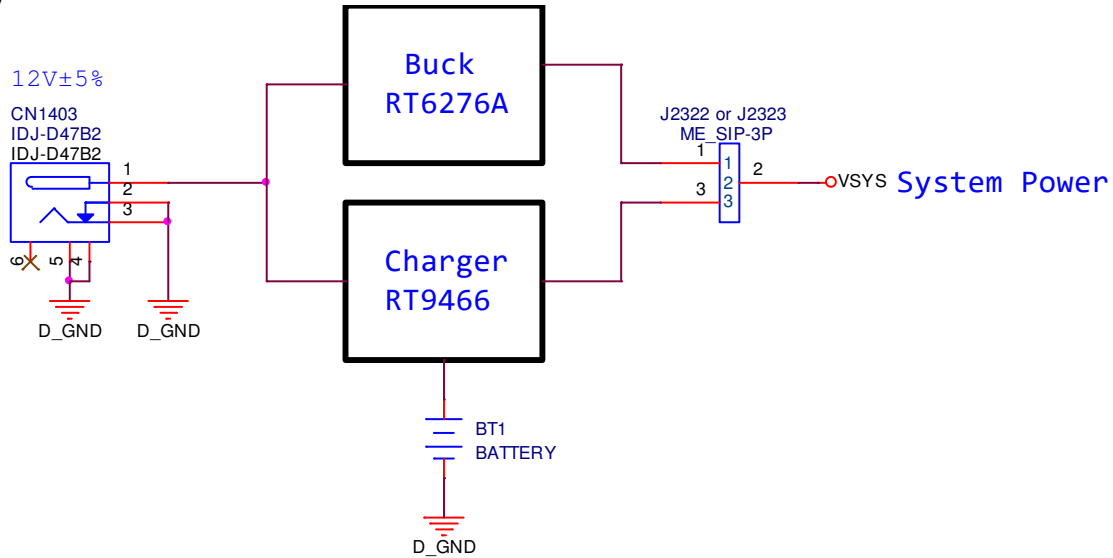

Figure 3-1 System Power Path

These two paths can be selected by J2322 and J2323. We provide two jumpers, 2 Ampere current rating for each. Usually, any one of them can meet the requirement for most cases.

Current Rating	System Power from Buck	System Power from Charger
2 Ampere	1-2 : Buck 2-3 : Charger	1-2 : Buck 2-3 : Charger
	Or	Or
	1-2 : Buck 2-3 : Charger	1-2 : Buck 2-3 : Charger

Current Rating	System Power from Buck	System Power from Charger
4 Ampere	<p>1-2 : Buck 2-3 : Charger</p> <p>J2323 J2322</p>	<p>1-2 : Buck 2-3 : Charger</p> <p>J2323 J2322</p>

Figure 3-2 Jumper Selection for System Power

3.3 I/O Interface

LED Indicators

There are three LED indicators.

LED Indicators	Location	Color	Note
System Power Indicator	D1206	Green	
Reset Indicator	D1207	Green	LED is off if reset signal is low.
System Power Indicator	D1001	Green	LED is on if system is on.
Charging Status Indicator	D1	Red	LED is on while charging.
System Power Indicator	D1206	Green	

Figure 3-3 Jumper Selection for System Power

UART

There are two UART (UART0 and UART1) consoles with USB to UART Bridge ICs on Genio 350-EVK. Users can use these consoles for debug purpose. The connectors are Micro USB type.

- Supports word Lengths from 5 to 8 bits with an optional parity bit and 1 or 2 stop bits
- Supports baud rates from 110 bps up to 961,200 bps
- FTDI USB to UART Bridge FT232RL

UART0	CON461 (Micro USB)	Core Processor Log
UART1	CON462 (Micro USB)	DSP Log
UART0	CON461 (Micro USB)	Core Processor Log

Table 3-4 UART Ports

I2C

- Four I2C buses (I2C0 to I2C3)
- Supports Master Mode Only
- Adjustable clock speed for LS/FS/FS+ mode operation
- Supports 7-bit address

I2C Bus	Purpose	Note	I2C Bus
I2C0	Battery Charger Raspberry Pi I/O	RichTek RT9466GQW	I2C0
I2C1	Capacitive Touch Controller HDMI Bridge IC	Goodix GS9271 ITE IT66121FN	I2C1
I2C2	Camera Sub-Board (MIPI CSI0) Raspberry Pi I/O		I2C2
I2C3	Camera Sub-Board (MIPI CSI1)		I2C3

Table 3-5 I2C Bus

SPI

- Support Master/Slave mode
- One chip select output.

PWM

- PWM supports Old mode and FIFO mode
- The frequency can be set from 0Hz to 39MHz

Raspberry Pi like I/O Interface

The pin definitions are as followings:

Pin #	Description	Note	Pin #	Description	Note
1	3.3V		2	5V	
3	SDA2	Camera 0 I2C	4	5V	
5	SCL2	Camera 0 I2C	6	GND	
7	IO124		8	TXD2	GPIO40
9	GND		10	RXD2	GPIO39
11	IO127		12	IO22	
13	IO33		14	GND	
15	IO109		16	IO136	
17	3V3		18	IO137	
19	SPI_MO	GPIO29	20	GND	
21	SPI_MI	GPIO28	22	IO140	
23	SPI_CLK	GPIO27	24	SPI_CS	GPIO26
25	GND		26	IO141	
27	SDA0	GPIO57	28	SCL0	GPIO58
29	IO25		30	GND	
31	IO142		32	PWM_A	GPIO19
33	PWM_C	IRRX	34	GND	
35	IO144		36	IO139	
37	IO138		38	IO34	
39	GND		40	IO32	

Table 3-6 Pin Assignments of the Raspberry Pi like I/O Connector

Note:

1. VDD_5V power can provide 5V/2A maximum but share with USB Host VBUS 5V output.
2. VGPIEXT_3V3 power can deliver 3.3V/300mA
3. Black words are ground pins.
4. Red words are power pins.
5. Green words are special function pins.
6. Blue words are GPIOs.
7. Pink words are pins, which multiplex with other function. Please check section 3.14 Pin Mux for Other Interfaces

3.4 MicroSD Slot

Genio 350-EVK has one MicroSD slot. It uses MT8365 MSDC1 interface and supports following features.

- Default Speed Mode
- High Speed Mode
- SDR12 Mode
- SDR25 Mode
- SDR50 Mode
- SDR104 Mode
- DDR50 Mode
- Support 1bit/4bit SD Bus Width

3.5 Power and Function Key Interface

12V power supplies to the system from a 2.0mm DC Jack. Power-on button and Reset button on the evaluation-board to turn on and reboot the system. Volume-Up and Volume-Down buttons make the operation easier.

3.6 USB Device

Genio 350-EVK has one USB Device port, which can be used for ADB debug port.

3.7 USB Host

Genio 350-EVK has one USB Host port for USB device connection, with USB Type-A connector.

3.8 Audio Interface (Earphone and Line Out)

Genio 350-EVK provides a 3.5mm earphone jack (with a microphone input) and another 3.5mm audio jack for Line Out (no audio amplifier is build-in).

3.9 Microphones

Genio 350-EVK provides one analog microphone (Merry MMA102-006) and two digital microphones (Merry MMD300-007).

Location	Type	Note
U700	Analog Microphone	To PMIC MT6357
U701	Digital Microphone 0	To Processor MT8365
U702	Digital Microphone 1	To Processor MT8365

Table 3-7 Microphone Input

3.10 MIPI DSI Interface

Genio 350-EVK provides one 4-lane MIPI DSI interface. A StarTek LCM (KD070FHFID015-C021A) with touch pad is provided in the box. The I2C capacitive touch controller is Goodix GT9271.

- Up to 1.2Gbps for 1-Data Lane
- Pixel format of RGB565/RGB666 or Loosely RGB666/RGB888
- Support peripheral TE and external TE signal detection

3.11 MIPI CSI Interface

Genio 350-EVK provides two 4-lane CSI interfaces, the CSI interface operates up to a maximum bit rate of 1.5Gbps per lane. Camera sub-boards are connected through SAS SFF-8087 cables.

3.12 Ethernet MII and RMII Interfaces

Ethernet MII/RMII interface shares some pins with HDMI interface. Some configurations should be done before booting up.

- Operate with an external Ethernet PHY (Realtek RTL8201F-VD-CG)
- Dynamically configurable to support 10/100M with MII/RMII
- CRC-32 checking with optional forwarding of the FCS field to the user application
- Optional magic packet detection
- EEE (Energy Efficient Ethernet) MII signaling according to the IEEE 802.3az specification
- RJ-45 Ethernet connector with transformer and LEDs in it.

The codes released are for RMII interface. Please select RMII interface via J2319 and J2320.

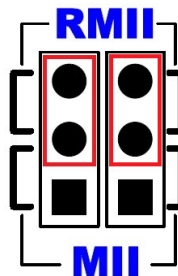

Figure 3-2 Genio 350-EVK Main Board Placement

3.13 How to Switch between HDMI and Ethernet Interfaces

DPI and Ethernet MII/RMII Interfaces share some GPIO pins. These two functions can not exist simultaneously. Reflash code and reboot system might be necessary when you switch between the interfaces. A mount of analog switch ICs (74LVC2G53) are used to switch these two interfaces. The work could be done via a DIP switch easily. The DPI interface will be converted to an HDMI output port through a bridge IC (ITE IT66121FN).

GPIO	Ethernet MII/RMII	HDMI
SW2101	Off	ON
GPIO0	EXT_TXD0	DPI_D0
GPIO1	EXT_TXD1	DPI_D12
GPIO2	EXT_TXD2	DPI_D2
GPIO3	EXT_TXD3	DPI_D3
GPIO4	EXT_TXC	DPI_D4
GPIO5	EXT_RXER	DPI_D5
GPIO6	EXT_RXC	DPI_D6
GPIO7	EXT_RXVD	DPI_D7
GPIO8	EXT_RXD0	DPI_D8
GPIO9	EXT_RXD1	DPI_D9
GPIO10	EXT_RXD2	DPI_D10
GPIO11	EXT_RXD3	DPI_D11
GPIO12	EXT_TXEN	DPI_DE
GPIO13	EXT_COL	DPI_VSYNC
GPIO14	EXT_MDIO	DPI_CK
GPIO15	EXT_MDC	DPI_HSYNC

Table 3-8 Pin Mux for HDMI and Ethernet MII/RMII Interface

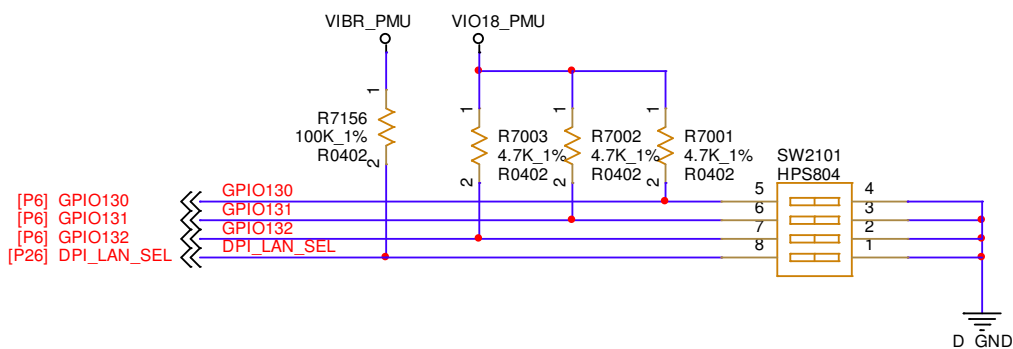

Figure 3-3 SW2102 Circuit



Figure 3-4 SW2102 DIP Switch

3.14 HDMI Port

Genio 350 EVK provides an HDMI port, users can connect external displays. Since HDMI signals come from the DPI interfaces of the processors (MT8365) through a bridge IC. The maximum resolution is constrained by DPI bandwidth. 1080p30 is the limitation. Unfortunately, most PC displays support 1080p60 only, but TVs support this resolution usually. So 720p60 is the recommendation, if you connect with a PC display.

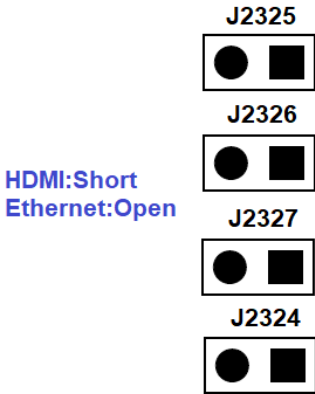

Figure 3-5 When using HDMI or Ethernet, pay attention to the following jumps

3.15 Pin Mux for Other Interfaces

There are some GPIOs shared with HDMI, M.2 slot (MT7663), on-board WiFi chip (MT6631), JTAG, IrDA Receiver and Raspberry Pi like I/O. You should pay attention on them when you use these functions.



Figure 3-6 Jumper J2318

J2318	Open	Short
GPIO	Raspberry Pi I/O	MT6631 / JTAG
GPIO32	RasPi_GPIO32	JTDI
GPIO33	RasPi_GPIO33	JTDO
GPIO34	RasPi_GPIO34	JTRST
GPIO136	RasPi_GPIO136	CONN_TOP_CLK
GPIO137	RasPi_GPIO137	CONN_TOP_DATA
GPIO138	RasPi_GPIO138	CONN_HRST_B
GPIO140	RasPi_GPIO140	CONN_BT_CLK
GPIO141	RasPi_GPIO141	CONN_BT_DATA
GPIO142	RasPi_GPIO142	CONN_WF_CTRL0
GPIO143	RasPi_GPIO143	CONN_WF_CTRL1
GPIO144	RasPi_GPIO144	CONN_WF_CTRL2
GPIO144	RasPi_GPIO139	CONN_WB_PTA

Table 3-9 Pin Mux Controlled by Jumper J2318

Location	Short Pin 1 and Pin 2	Use Pin 2 and Pin 3
J1303	RasPi_PWM_3V3	IRRX_3V3

Table 3-10 Pin Mux Controlled by Jumpers J1303

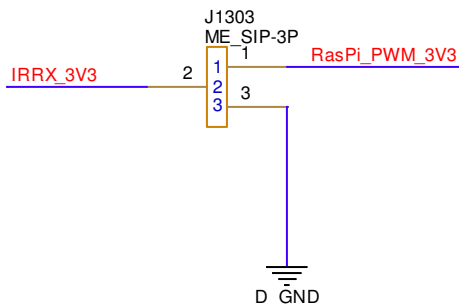

Figure 3-7 Circuit for Jumpers J1303

3.16 On-Board Antenna

Genio 350-EVK has three on-board antennas. Users can connect them via coaxial cables. These antennas are designed for AzueWave M.2 (MT7663) WiFi module, also can be used for MT6631 on-board WiFi chip.

Location	Band	Note
CON3303	2.4GHz / 5GHz	WiFi
CON3304	2.4GHz / 5GHz / 1.6GHz	WiFi / BT / GPS
CON3305	2.4GHz	BT

Table 3-11 On-Board Antennas

3.17 LCM FPC Installation

Please connect LCM FPC in this way.

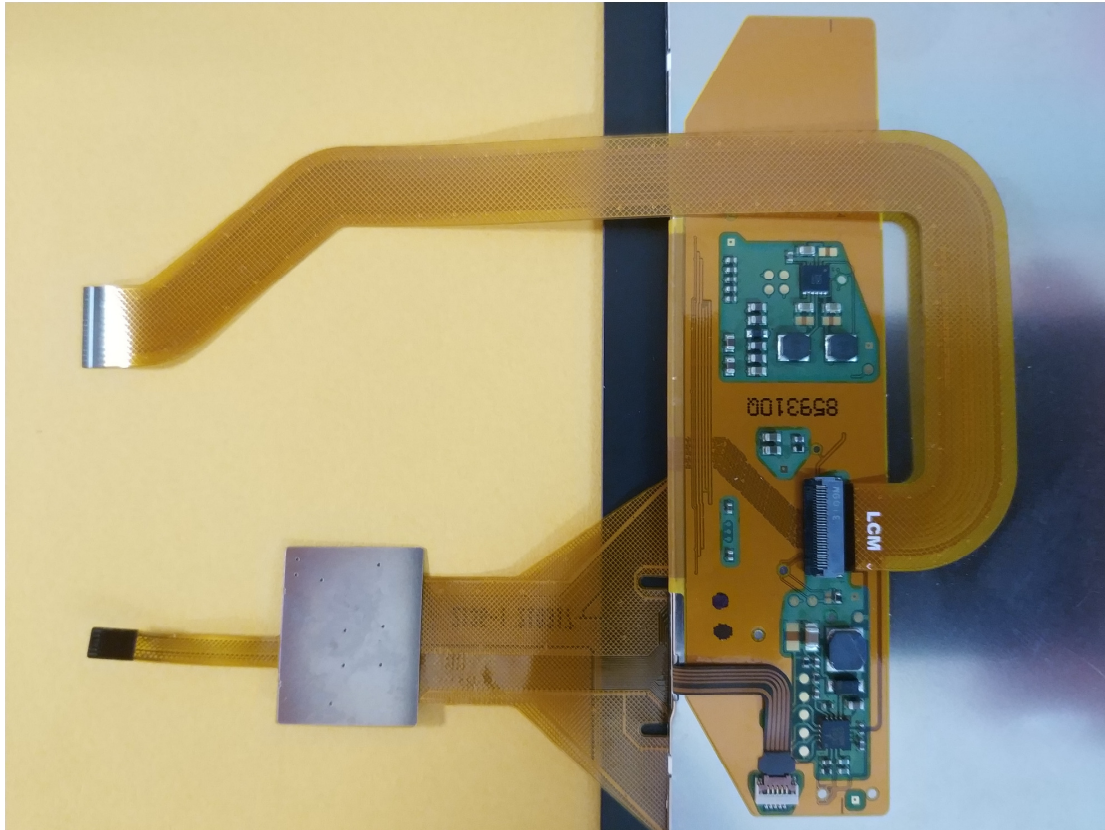

Figure 3-8 LCM FPC Installation

3.18 How to Power Up The System

You may power on Genio 350-EVK by following steps.

1. Connect UART0 to the computer via an USB cable. (If you want to see the logs.)
2. Plug in the DC 12V power cord.
3. You will see the boot-up picture on LCD display, or some trace logs come out from UART0.

3.19 How to flash Image to the Board

1. Download prebuilt board image:

<https://mediatek.gitlab.io/aiot/doc/aiot-dev-guide/sw/yocto/download.html#prebuilt-board-images>

2. How to reflash image, please see the documentation from website:

<https://mediatek.gitlab.io/aiot/doc/aiot-dev-guide/sw/yocto/get-started/flash/flash-Genio 350-evk.html>

3.20 Debug

- Micro USB output UART log
- Please install FT232RL driver for micro-USB

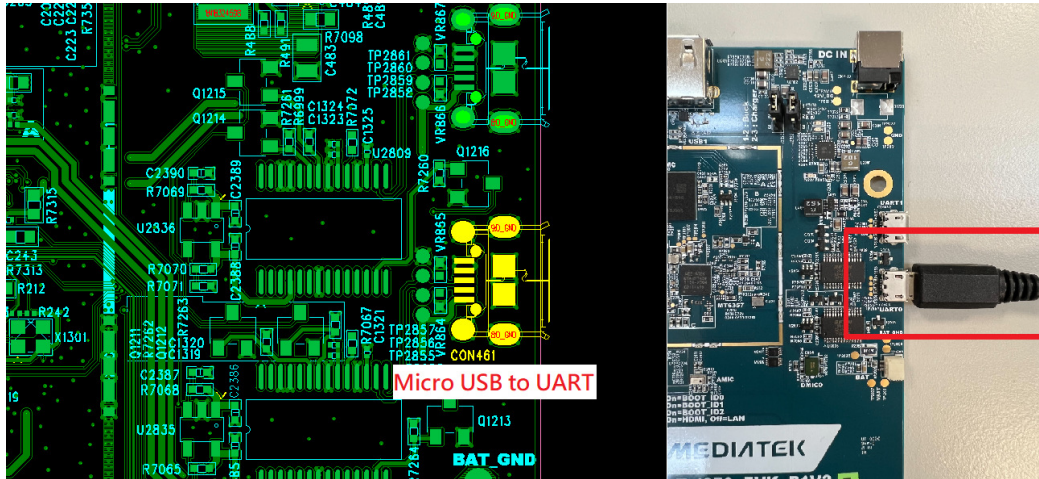

Figure 3-9 Debug Port

- Check PC USB port could be recognized the UART device
- Setting serial, speed to 921600 and press OPEN on putty for Log(Example on Putty)

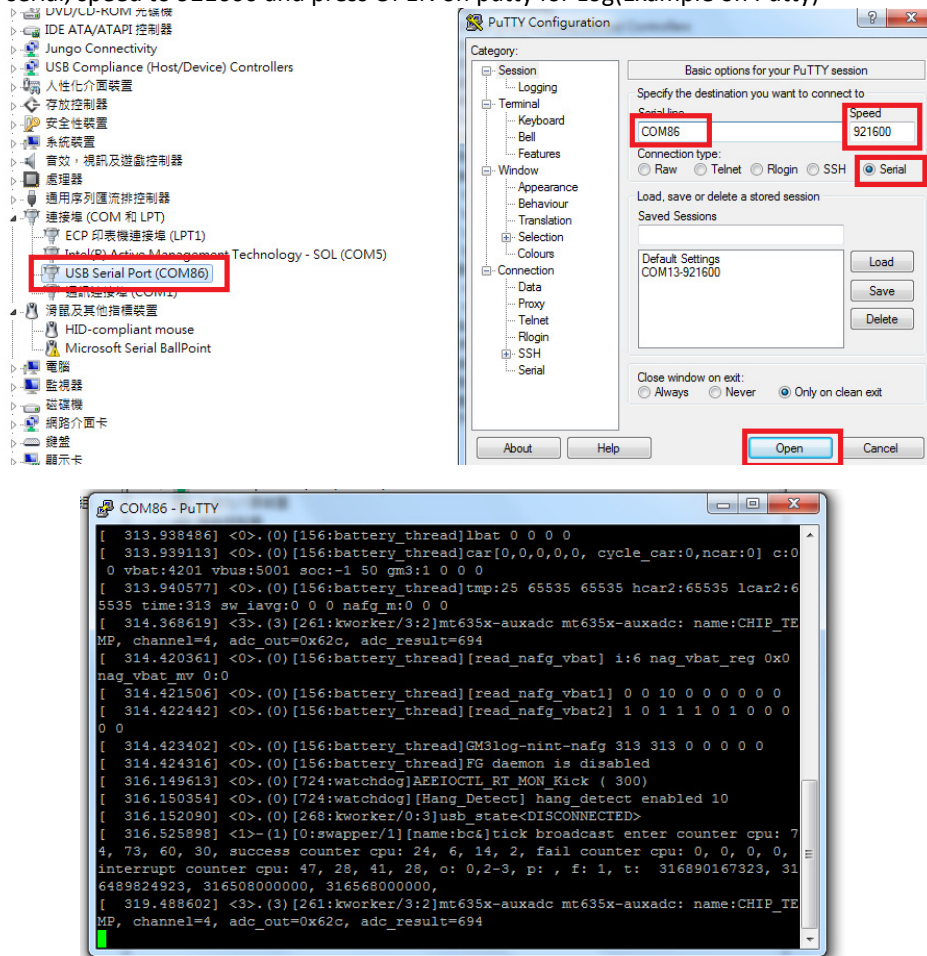

Figure 3-10 Log setting

4 Camera Sub-Board

The camera sub-board has two MIPI CSI paths, one connects with the processor (MT8365) on main board directly, the other connects with the main board through an ISP (On-Semiconductor AP1302CSSL00SMGA0-DR). These two MIPI paths are switched by a MIPI multiplexer (TI TS3DV642RUARQ1).

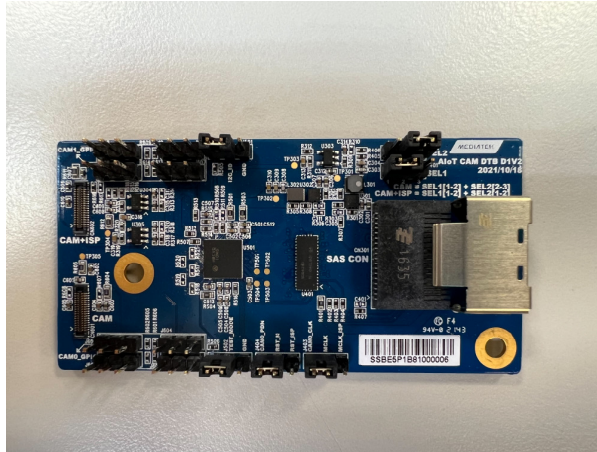

Figure 4-1 Camera Sub-Board

4.1 Feature

- 4-Lane MIPI CSI Interface
- Connects the main board with an SAS SFF-8087 cable.
- Supports camera module with/without ISP (On-Semiconductor AP1302CSSL00SMGA0-DR)
- Since main board has two CSI interfaces, there are two camera sub-board and two APPLETEC 4M pixel camera modules (AP-CM-54-4.0-70 with ON-Semiconductor CMOS image sensor AR0430) in the package.

4.2 Camera Sub-Board Block Diagram

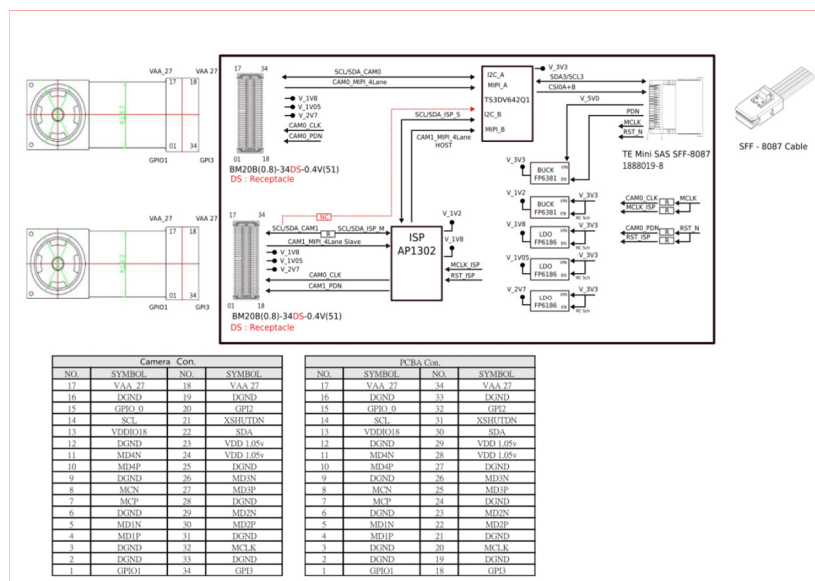

Figure 4-2 Block Diagram of Camera Sub-Board

4.3 How to Configure the MIPI CSI Path

Location	Note
J401	Select signal path
J402	Select signal path
J403	MCLK switch
J404	RST switch
J502	AP1302 test mode

Table 4-2 Jumper Selection for CAM or CAM+ISP

Setting	Direct to Main Board (CAM Only)	Through ISP (CAM + ISP)
Camera Module	Put camera module on CON601	Put camera module on CON602
Jumper	<ol style="list-style-type: none"> Put a shunt to short J401 pin 1 and pin 2. Put a shunt to short J402 pin 2 and pin 3. Put a shunt to short J403 pin 1 and pin 2. Put a shunt to short J404 pin 1 and pin 2. Put a shunt to short J502 pin 1 and pin 2 	<ol style="list-style-type: none"> Put a shunt to short J402 pin 1 and pin 2. Put a shunt to short J402 pin 1 and pin 2. Put a shunt to short J403 pin 2 and pin 3. Put a shunt to short J404 pin 2 and pin 3. Put a shunt to short J502 pin 2 and pin 3. 

Table 4-1 Block Diagram of Camera Sub-Board

5 Reference Documents

5.1 Contains in The Box

Item	Quantity	Note
Genio 350-EVK Main Board	1	
Genio 350-EVK Camera Sub-Board	2	
SAS FFS-8087 Cable (25 cm)	2	For Camera Sub-Board
12V DC Power Brick	1	

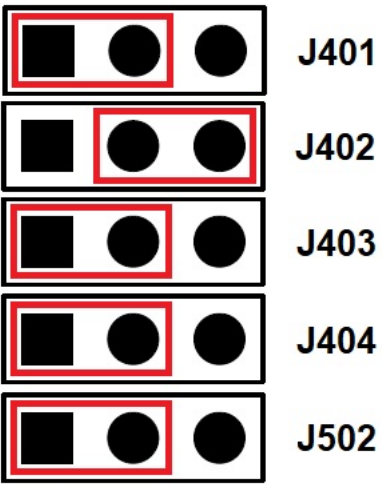
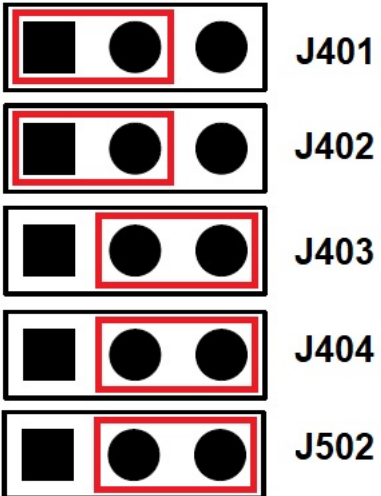
Figure 5-1 Contains in The Box

5.2 PCBA Version

PCBA	Name	Version
Main Board	Genio 350-EVK Main board	P1V3
Camera Board	Genio 350-EVK Camera	D1V2

Figure 5-2 MediaTek PCBA Naming Rule

5.3 Disclaimer

Genio 350-EVK are supplied “as is” and without warranties of any kind, express, implied, or statutory including, but not limited to, any implied warranty for a particular purpose. No license is granted by implication or otherwise under any patents or other intellectual property by application or use of evaluation boards. Information furnished by MediaTek is believed to be accurate and reliable. MediaTek reserves the right to change specifications or product description in this document at any time without notice.

Should Buyer purchase or use MediaTek’s products for any such unintended or unauthorized application, Buyer shall indemnify and hold MediaTek harmless against all claims and damages. MediaTek is the trademarks of MediaTek Mobile Technology Corp. Other trademarks and registered trademarks mentioned herein are the property of their respective owners.