



mSATA ArmourDrive™

86 Series

Product Brief

Product Description

The mSATA ArmourDrive™ family consists of high-reliability, industrial solid state drives (SSDs) in a wide selection of capacities and endurance specifications. To better address customer needs, the 86 Series is available with 1-bit-per-cell (SLC) or 3-bit-per-cell (TLC) 3D NAND configurations. ArmourDrive SSDs designed with Greenliant's EnduroSLC™ Technology can reach ultra-high write endurance of 300K program/erase (P/E) cycles. Operating at extreme temperatures, mSATA ArmourDrive is ideal for applications requiring removable data storage able to withstand the most demanding environments.

The 86 Series implements advanced NAND flash management technology to preserve data integrity and extend SSD lifespan. Built in the standard JEDEC MO-300 form factor and backed by Greenliant's technical support, mSATA ArmourDrive gives industrial, computing, security, video and networking customers added flexibility when selecting reliable solid state storage for space-constrained, embedded systems.



Key Features

Small Form Factor SATA SSD

- 29.85mm x 50.80mm x 4.80mm
- JEDEC MO-300, full length

Industry Standard Serial ATA Bus Interface

- Supports SATA 6Gb/s, 3Gb/s and 1.5Gb/s
- ATA/ATAPI-8 compliant
- Supports 48-bit address feature set

Energy Efficient

- 3.3V low power supply
- Standby Mode less than 335mW*
- Slumber Mode less than 15mW*

High Performance*

- Sequential Read / Write performance up to 550MB/s / 500MB/s
- Optimizes order of commands with Native Command Queuing (up to 32 commands)

*SATA 6Gb/s mSATA PX Series

Pre-programmed Firmware

- Configurable algorithms optimize wear leveling and data retention
- Embedded FFS enables seamless capacity upgrade with no change to host software

Advanced Flash Management

- Dynamic and static wear leveling algorithms maximize product lifespan
- Supports TRIM commands to remove invalid data which is no longer in use

Bad Block Management

- Replaces bad blocks with spare blocks in the NAND flash to prevent uncorrectable errors

Power Interrupt Data Protection

- Helps prevent data corruption when power is lost or unstable

Built-in ECC

- Advanced bit error detection and correction

High Reliability

- MTBF more than 2,000,000 hours

Data Security

- Secure Erase for quick data wipe/factory reset

SSD Lifespan Monitoring

- Enables SMART command-based alerts indicating the remaining useful product life

Wide Range of Capacities

- 8 GB - 32 GB (SATA 1.5Gb/s products)
- 4 GB - 1 TB (SATA 6Gb/s products)
- Available in different NAND configurations to meet various endurance requirements

Industrial and Commercial Temperatures

- Industrial operation: -40°C to +85°C
- Commercial operation: 0°C to +70°C

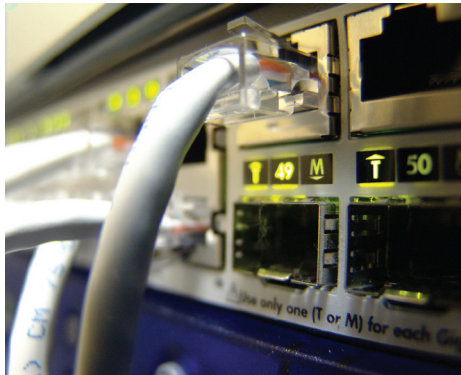

Applications

- Industrial PC
- Set-top box / Net-top box
- Medical equipment
- Transportation
- Digital signage
- Industrial automation & control
- Test & measurement
- Blade server
- Gateway / Switch
- Network firewall
- Surveillance
- Data recorder
- Video conferencing
- GPS and telematics
- In-vehicle infotainment
- Multi-function printer

Greenliant

3970 Freedom Circle, Suite 100
Santa Clara, CA 95054 USA
Tel: 1-408-200-8000
Fax: 1-408-200-8099

www.Greenliant.com

mSATA ArmourDrive Board Diagrams

29.85mm x 50.80mm x 4.85mm (max)
JEDEC MO-300, full length
Pb-free (RoHS compliant)

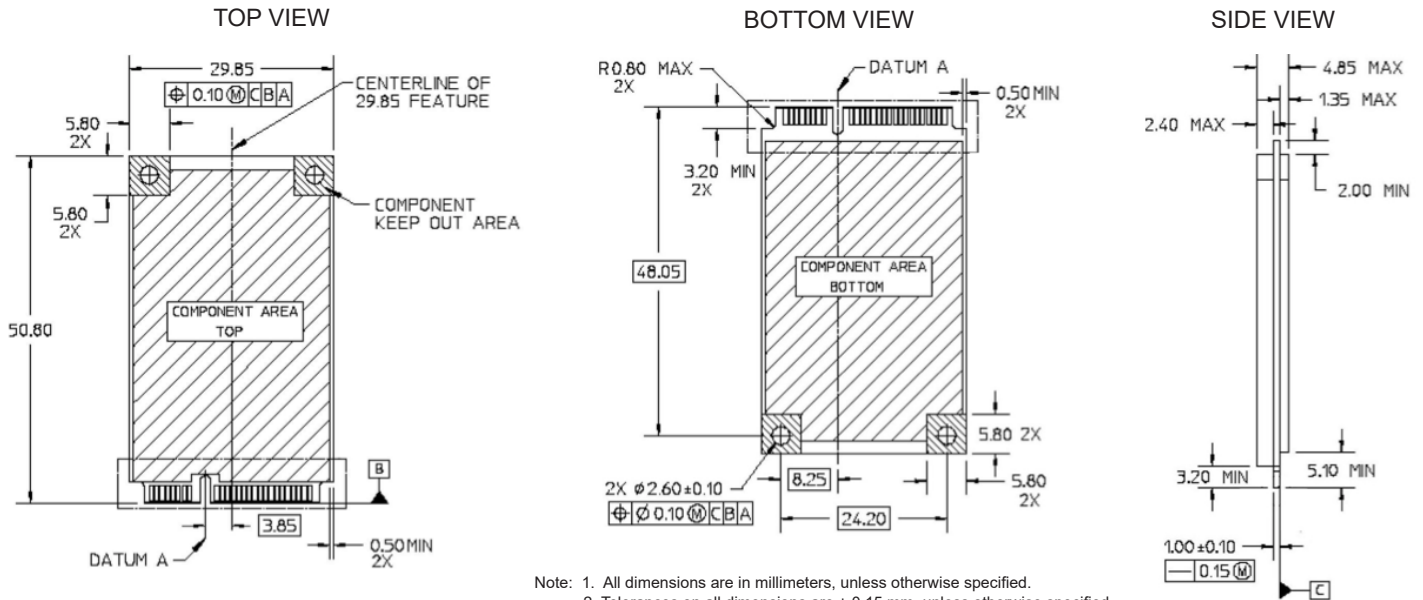

mSATA ArmourDrive Block Diagram

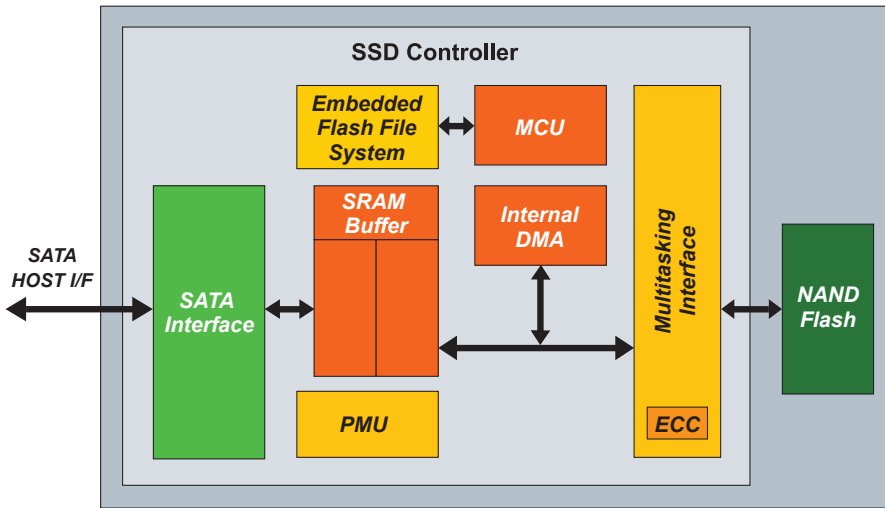

Product Lineup

| 86 Series mSATA ArmourDrive | | | |
|-----------------------------|------------------------------|---|--|
| SATA Interface | Product Series / Capacity | NAND Configuration / Endurance | Temperature Range |
| 1.5Gb/s | 8 GB – 32 GB | 1-bit-per-cell SLC NAND / 60K P/E cycles | Industrial -40°C to +85°C |
| 6Gb/s | EX 4 GB - 320 GB | 1-bit-per-cell SLC NAND / 60K, 120K, 300K P/E cycles* | |
| | PX 64 GB - 512 GB | 3-bit-per-cell TLC NAND / 5K P/E cycles | |
| | PX PX 32 GB - 1 TB | 3-bit-per-cell TLC NAND / 3K P/E cycles | Industrial -40°C to +85°C Commercial 0°C to +70°C |

*Designed with Greenliant's advanced EnduroSLC Technology 300K endurance offered up to 160GB **EnduroSLC™**

twitter.com/Greenliant
 linkedin.com/company/Greenliant
 facebook.com/Greenliant

ArmourDrive FAQs: www.greenliant.com/armourdrive-faqs

For more information, contact your Greenliant representative: www.greenliant.com/sales



© 2021 Greenliant
 Greenliant, the Greenliant logo, EnduroSLC and ArmourDrive are trademarks of Greenliant.
 These specifications are subject to change without notice. 11/2021