

## Features

- **Industry Standard SATA Host Interface**
  - SATA 1.5Gb/s, 3Gb/s and 6Gb/s
  - SATA Revision 3.2
  - ATA/ATAPI-8 compliant
  - Supports 48-bit address feature set
  - Native Command Queuing (NCQ) up to 32 commands
- **Performance**
  - Sequential data read: Up to 470 MB/s
  - Sequential data write: Up to 340 MB/s (measured using 128KB transfer size)
- **Power Management**
  - 3.3V power supply
- **Power Consumption**
  - Active mode:
    - 128GB: Up to 2180mW
    - 64GB: Up to 1800mW
    - 32GB: Up to 1980mW
    - 16GB: Up to 1540mW
    - 8GB: Up to 1200mW
    - 4GB: Up to 1200mW
  - Idle / Standby mode: <355mW
  - DevSleep mode: <70mW
- **Reliability**
  - Mean Time Between Failures (MTBF): 2 million hours
- **Expanded Data Protection**
  - Added data security through user-selectable protection zones
  - Secure erase / Data sanitization
- **20-Byte Serial Number**
  - Factory pre-programmed unique ID
  - User-programmable 10-Byte ID
- **Supports TRIM and SMART Commands**
- **Robust Built-in ECC**
- **Thermal Throttling**
- **NAND Configuration**
  - 1 bit per cell (SLC)
  - Designed with Greenliant's advanced EnduroSLC™ Technology
- **High Endurance**
  - GLS86FCxxxG1: 50K P/E cycles; Up to 5,000 TBW
  - GLS86FCxxxG8: 100K P/E cycles; Up to 10,000 TBW (P/E = program/erase; TBW = TeraBytes Written)
- **Operating Temperature Range**
  - Industrial: -40°C to 85°C
- **JEDEC standard MO-300 mSATA form factor**
  - 29.85 mm x 50.80 mm x 4.85 mm
- **All Devices are RoHS Compliant**

## Product Description

The GLS86FC004G1 / 008G1 / 016G1 / 032G1 / 064G1 / 128G1 / 008G8 / 016G8 / 032G8 / 064G8 / 128G8 Industrial Grade miniSATA (mSATA) ArmourDrive™ EX Series modules (referred to as “mSATA ArmourDrive” in this factsheet) are high-endurance, high-reliability solid state drives. They include a 4, 8, 16, 32, 64 or 128 GByte SATA NANDrive™ on a printed circuit board (PCB).

mSATA ArmourDrive is ideal for applications that require removable form factor and more reliable data storage. mSATA solid state storage technology is widely used in industrial computers, set-top boxes, test and measurement instrumentation, multi-functional printers, medical equipment, security and surveillance systems, network servers and digital signage. These removable solid state drives (SSDs) surpass traditional hard disk drives (HDDs) in their small size, security, reliability, ruggedness and low power consumption.

The NAND flash controller with built-in advanced NAND management firmware communicates with the host through the standard SATA protocol. It does not

require any additional or proprietary software such as the Flash File System (FFS) and Memory Technology Driver (MTD). The firmware effectively optimizes the use of NAND flash memory's program/erase (P/E) cycles and minimizes write amplification.

mSATA ArmourDrive is pre-programmed with a 10-Byte unique serial ID and has the option of programming an additional 10-Byte serial ID for even greater system security.

mSATA ArmourDrive's advanced NAND management technology improves endurance, enhances data security and helps prevent data corruption during unexpected power failure events. This innovative technology combines robust NAND flash controller hardware error correction capabilities with advanced wear-leveling algorithms and bad block management to improve data reliability and significantly extend the life of the product.

mSATA ArmourDrive is available in a standard JEDEC 52-pin PCB module form factor.

## 1.0 GENERAL DESCRIPTION

Each mSATA ArmourDrive module contains a NANDrive multi-chip package, which integrates a SATA NAND flash controller with discrete NAND flash die. Refer to Figure 2-1 for the mSATA ArmourDrive block diagram.

### 1.1 Optimized mSATA ArmourDrive

The heart of mSATA ArmourDrive is the SATA NAND flash controller, which translates standard SATA signals into flash media data and control signals. The following components contribute to mSATA ArmourDrive's operation.

#### 1.1.1 Microcontroller Unit (MCU)

The MCU translates SATA commands into data and control signals required for flash media operation.

#### 1.1.2 Internal Direct Memory Access (DMA)

mSATA ArmourDrive uses internal DMA allowing instant data transfer from/to buffer to/from flash media. This implementation eliminates microcontroller overhead associated with the traditional, firmware-based approach, thereby increasing the data transfer rate.

#### 1.1.3 Power Management Unit (PMU)

The PMU controls the power consumption of mSATA ArmourDrive. The PMU dramatically reduces the power consumption of mSATA ArmourDrive by putting the part of the circuitry that is not in operation into sleep mode.

The Flash File System handles inadvertent power interrupts and has auto-recovery capability to ensure mSATA ArmourDrive firmware integrity. For regular power management, the host must send an IDLE\_IMMEDIATE command and wait for command ready before powering down mSATA ArmourDrive.

#### 1.1.4 Embedded Flash File System

The embedded flash file system is an integral part of mSATA ArmourDrive. It is integrated in the controller's firmware that performs the following tasks:

1. Manages and optimizes the data access of flash media
2. Provides flash media wear leveling to spread the flash writes across all memory address space to increase the longevity of flash media
3. Keeps track of data file structures

#### 1.1.5 Error Correction Code (ECC)

The ECC technology uses advanced algorithms to detect and correct errors, ensuring data integrity and extending the SSD lifespan.

#### 1.1.6 Multi-tasking Interface

The multi-tasking interface enables fast, sequential write performance by allowing concurrent Read, Program and Erase operations to multiple flash media.

## 1.2 EnduroSLC™ Technology

EnduroSLC™ is a proprietary 3D NAND management technology developed by Greenliant for high reliability applications requiring ultra-high endurance and superior data retention. Using 1-bit-per-cell (SLC) NAND configuration, EnduroSLC enabled SSDs are ideal for write-intensive applications used in extreme temperature, high stress environments. EnduroSLC enabled solid state drives offer a high reliability flash storage solution with ultra-high write endurance that exceeds capabilities of legacy, planar SLC NAND based products.

## 1.3 Advanced NAND Management

mSATA ArmourDrive's controller uses advanced wear-leveling algorithms to substantially increase the longevity of NAND flash media. Wear caused by data writes is evenly distributed in all or select blocks in the device that prevents "hot spots" in locations that are programmed and erased extensively. This effective wear-leveling technique results in optimized device endurance, enhanced data retention and higher reliability required by long-life applications.

## 2.0 FUNCTIONAL BLOCKS

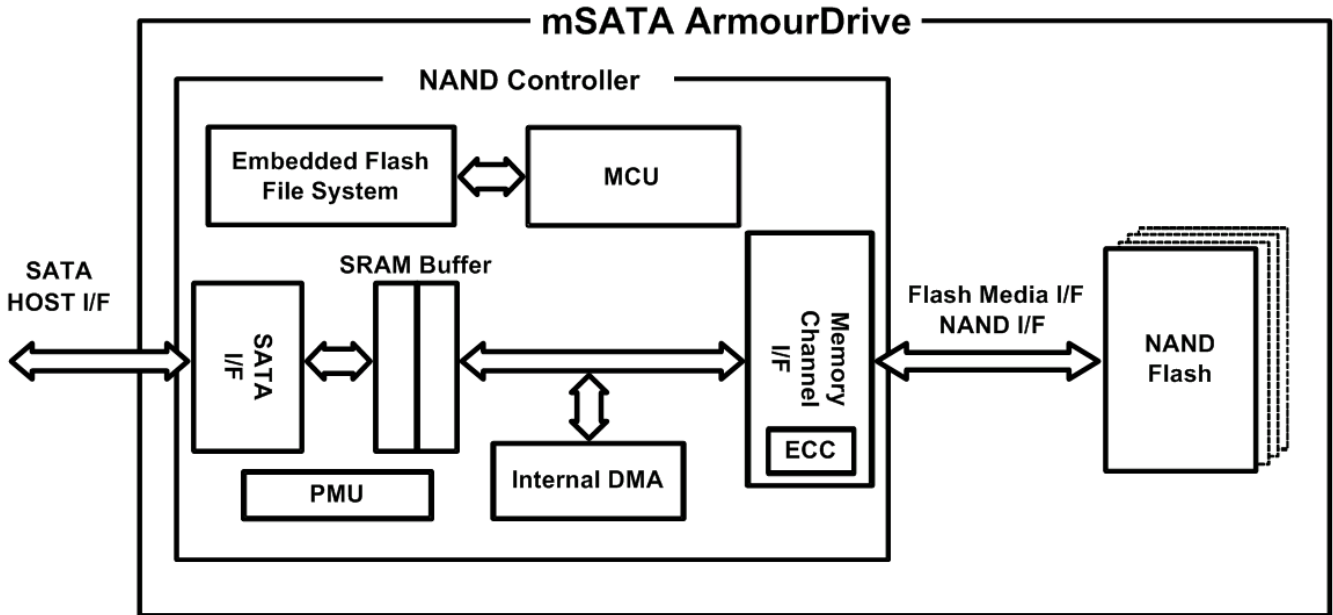
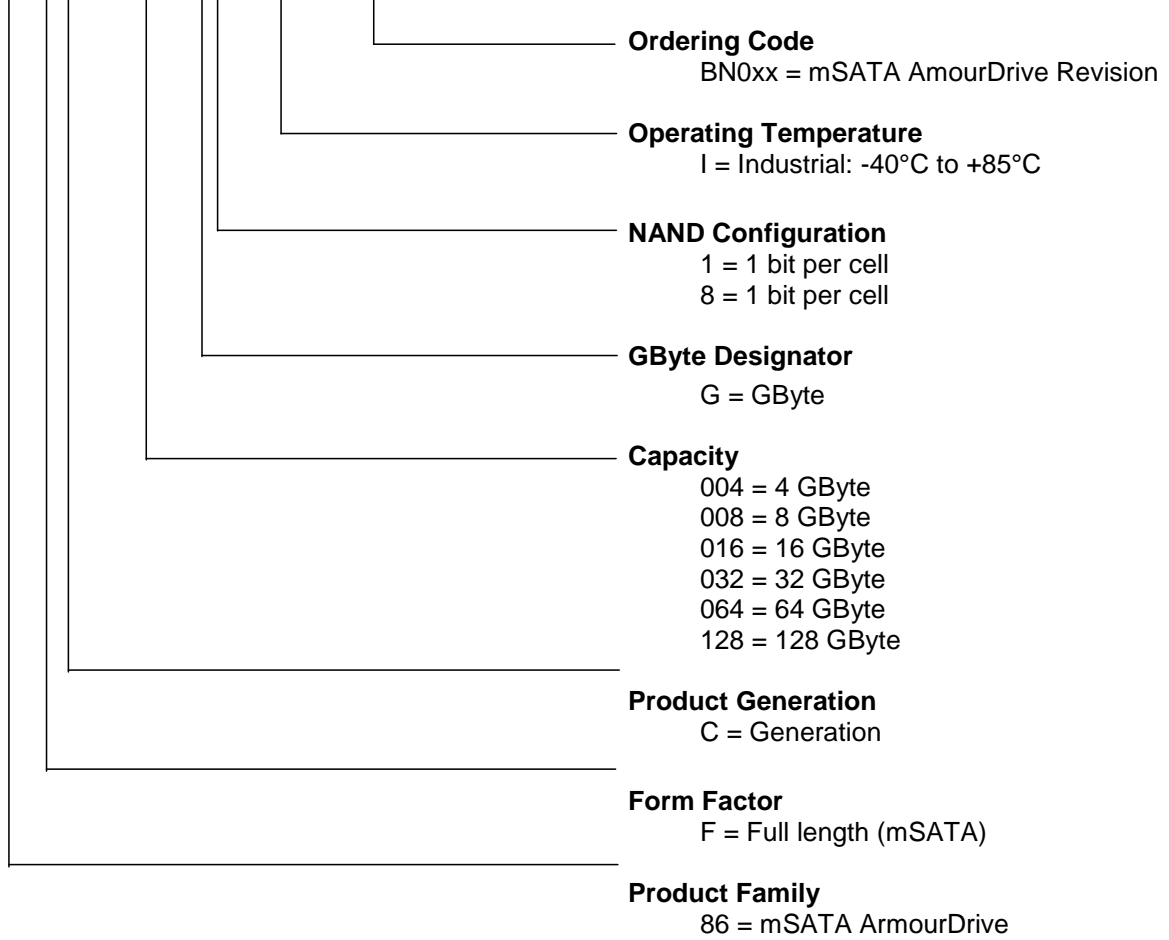

Figure 2-1: mSATA ArmourDrive Block Diagram

### 3.0 APPENDIX

#### 3.1 Product Ordering Information

GLS 86 FC xxx Gx - I - BN0xx  
 XX XX XXX XX - X - XXXXX



**Valid Combinations**

Valid product combinations are those that are in the mass production or will be in the mass production. Consult your Greenliant sales representative to confirm availability of the valid combinations and to determine availability of new product combinations.

**Table 3-1:**

Capacity	Operating Temperature	Part Number	Form Factor
4GB	Industrial (-40°C to 85°C)	GLS86FC004G1-I-BN007	JEDEC MO-300 (full length)
		GLS86FC004G1-I-BN011	
8GB	Industrial (-40°C to 85°C)	GLS86FC008G1-I-BN007	JEDEC MO-300 (full length)
		GLS86FC008G1-I-BN011	
		GLS86FC008G8-I-BN008	
		GLS86FC008G8-I-BN012	
16GB	Industrial (-40°C to 85°C)	GLS86FC016G1-I-BN007	JEDEC MO-300 (full length)
		GLS86FC016G1-I-BN011	
		GLS86FC016G8-I-BN008	
		GLS86FC016G8-I-BN012	
32GB	Industrial (-40°C to 85°C)	GLS86FC032G1-I-BN007	JEDEC MO-300 (full length)
		GLS86FC032G1-I-BN011	
		GLS86FC032G8-I-BN008	
		GLS86FC032G8-I-BN012	
64GB	Industrial (-40°C to 85°C)	GLS86FC064G1-I-BN007	JEDEC MO-300 (full length)
		GLS86FC064G1-I-BN011	
		GLS86FC064G8-I-BN008	
		GLS86FC064G8-I-BN012	
128GB	Industrial (-40°C to 85°C)	GLS86FC128G1-I-BN007	JEDEC MO-300 (full length)
		GLS86FC128G1-I-BN011	
		GLS86FC128G8-I-BN008	
		GLS86FC128G8-I-BN012	

### 3.2 Board Diagrams

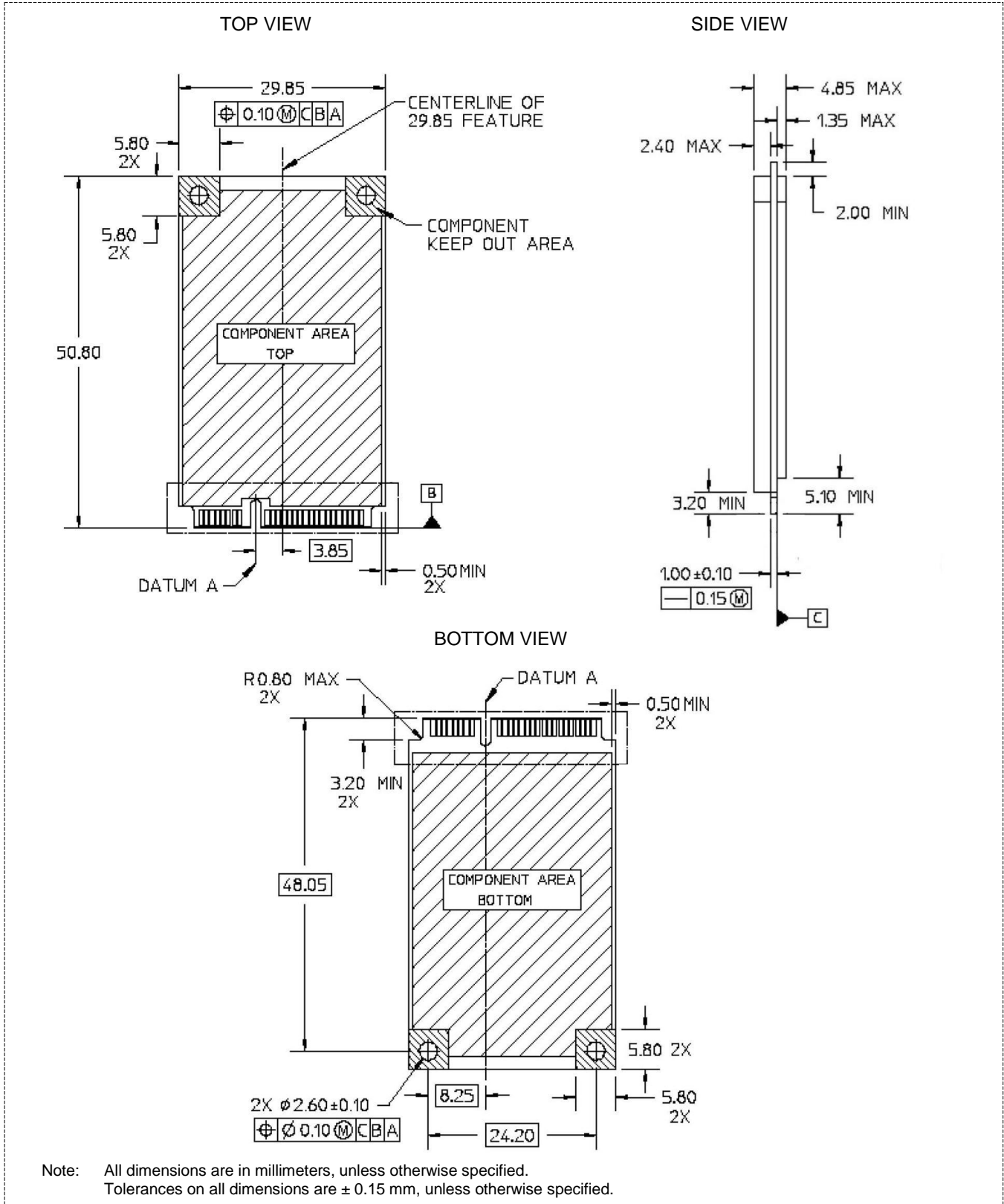

Figure 3-1: mSATA ArmourDrive Dimensions