



SATA 2.5" ArmourDrive™

89 Series

Product Brief

Product Description

The SATA 2.5" ArmourDrive™ family consists of high-reliability, industrial solid state drives (SSDs) in a wide selection of capacities. To better address customer needs, the 89 Series is available in commercial and industrial temperature ranges, and offers both DRAM and DRAM-less SSDs. Operating at extreme temperatures, and tested for shock and vibration, SATA 2.5" ArmourDrive is ideal for applications requiring removable data storage able to withstand the most demanding environments.

The 89 Series implements advanced NAND flash management technology to preserve data integrity and extend SSD lifespan. Built in the standard 2.5" form factor and backed by Greenliant's technical support, SATA 2.5" ArmourDrive gives industrial, computing, security, video and networking customers added flexibility when selecting reliable, hot-swappable solid state storage for embedded systems.



Key Features

2.5" Form Factor SATA SSD

- 100mm x 69.85mm x 7.00mm
- SATA 6Gb/s, 3Gb/s and 1.5Gb/s
- Compliant with SATA Revision 3.2
- Supports 48-bit address feature set

High Performance

- Sequential Read / Write performance up to 550MB/s / 530MB/s
- Native Command Queuing up to 32 commands
- DRAM for better sustained performance (select models)

Data Security

- Secure Erase for quick data wipe/factory reset
- AES-256 / TCG OPAL hardware encryption (select models)

Pre-programmed Firmware

- Field-upgradeable firmware to add new features and enhance device performance
- Configurable algorithms optimize data retention based on the usage model
- Embedded FFS enables seamless capacity upgrade with no change to host software

Advanced Flash Management

- Dynamic and static wear leveling algorithms maximize product lifespan
- Supports TRIM commands to remove invalid data which is no longer in use

Bad Block Management

- Replaces bad blocks with spare blocks in the NAND flash to prevent uncorrectable errors

SSD Lifespan Monitoring

- Supports SMART command-based alerts indicating the remaining useful product life

Built-in ECC

- Uses advanced bit error detection and correction optimized for 3D NAND

Power Interrupt Data Protection

- Helps prevent data loss during unexpected power failure events

Wide Range of Capacities

- 32 GB - 1 TB
- 128 GB - 3.84 TB (with DRAM)

Industrial and Commercial Temperatures

- Industrial operation: -40°C to +85°C
- Commercial operation: 0°C to +70°C

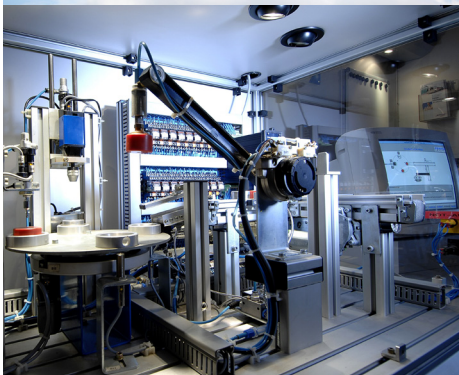
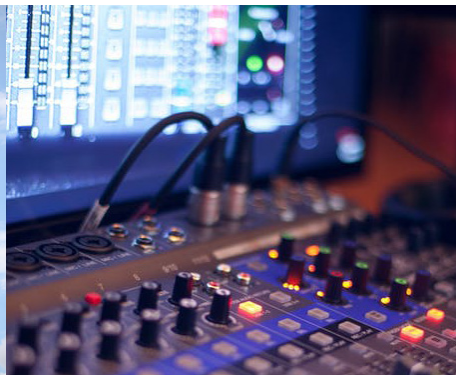

Applications

- Blade server
- Gateway / Switch
- Multi-function printer
- Aviation
- Base station
- Industrial automation & control
- Broadcasting
- Infotainment
- Navigation
- Digital signage
- Transportation
- Security / Surveillance
- Network-attached storage
- Data logger
- Healthcare
- Test & measurement

Greenliant

3970 Freedom Circle, Suite 100

Santa Clara, CA 95054 USA

Tel: 1-408-200-8000

Fax: 1-408-200-8099

www.Greenliant.com

SATA 2.5" ArmourDrive Board Diagrams

100mm x 69.85mm x 7.00mm
Pb-free (RoHS compliant)

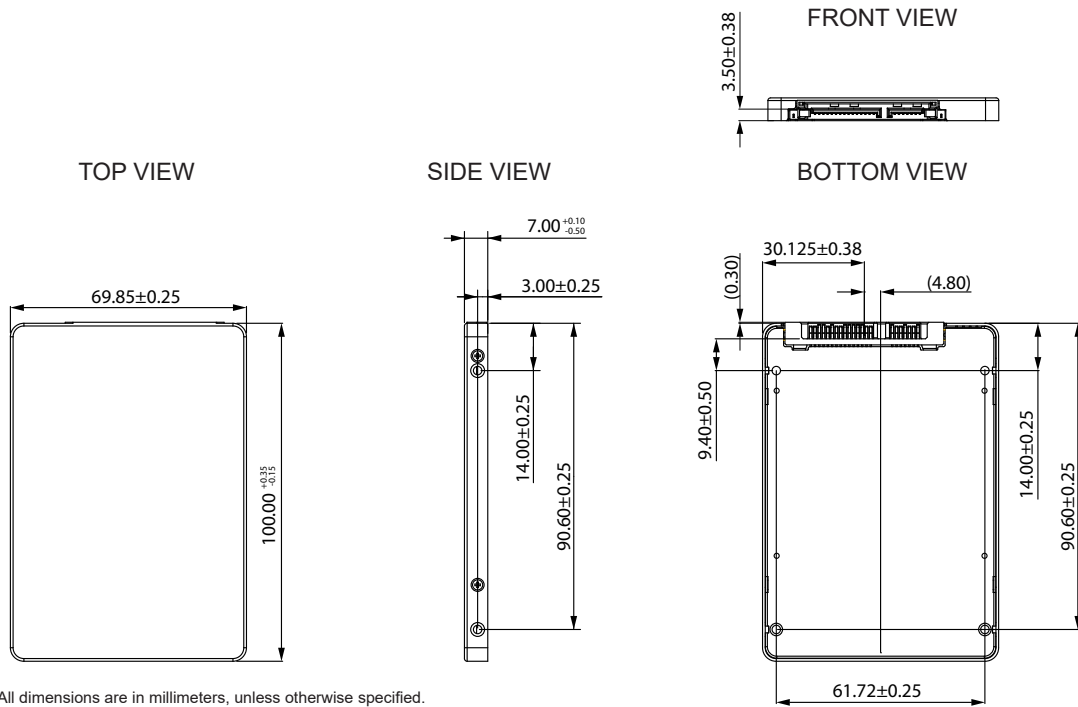

SATA 2.5" ArmourDrive Block Diagram

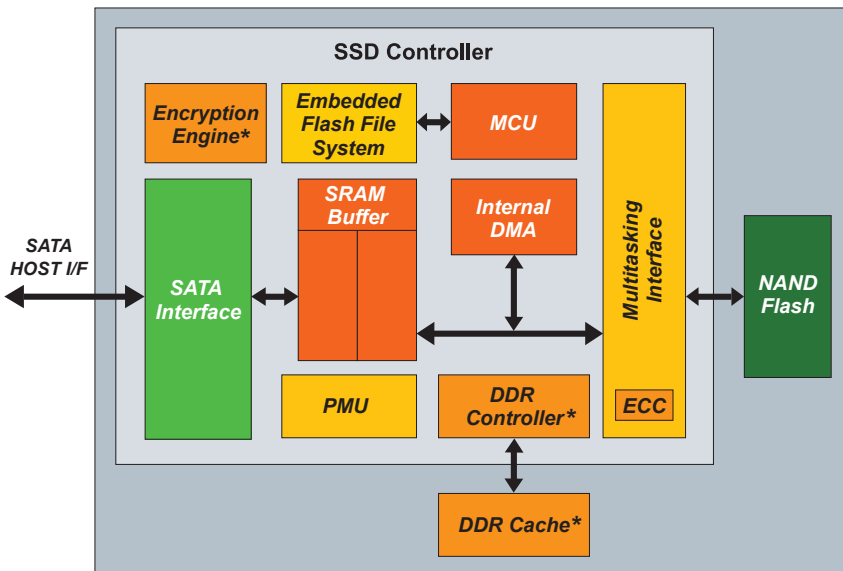

Product Lineup

89 Series SATA 2.5" ArmourDrive			
Product Series / Capacity	DRAM	NAND Configuration / Endurance	Temperature Range
PX 32 GB - 1 TB	No		Industrial -40°C to +85°C
PX 240 GB - 3.84 TB	Yes	3-bit-per-cell TLC NAND / 3K P/E cycles	
PX 128 GB - 2 TB			Commercial 0°C to +70°C

twitter.com/Greenliant
linkedin.com/company/Greenliant
facebook.com/Greenliant

ArmourDrive FAQs: www.greenliant.com/armourdrive-faqs

For more information, contact your Greenliant representative: www.greenliant.com/sales



© 2021 Greenliant
Greenliant, the Greenliant logo and ArmourDrive are trademarks of Greenliant.
These specifications are subject to change without notice. 10/2021