

Product Description

The CFast ArmourDrive™ family consists of high-reliability, industrial flash memory cards that offer low power consumption and hot-swap flexibility. Providing multiple capacities in a small form factor, the 91 Series offers high performance with SATA 6Gb/s support and an easy upgrade path from legacy PATA-interface CompactFlash cards. Operating at extreme temperatures, and tested for shock and vibration, CFast ArmourDrive is ideal for applications requiring removable data storage able to withstand demanding environments.

The 91 Series implements advanced NAND flash management technology to preserve data integrity and extend memory card lifespan. Built in the standard CFast form factor and backed by Greenliant's technical support, CFast ArmourDrive gives industrial, medical, gaming, video and imaging customers added flexibility when selecting reliable, hot-swappable solid state storage for space-constrained, embedded systems.



Key Features

Form Factor and Interface

- 36.40mm x 42.85mm x 3.60mm
- Supports SATA 6Gb/s, 3Gb/s and 1.5Gb/s
- Compliant with SATA Revision 3.2

High Performance

- Sequential Read / Write performance up to 550MB/s / 490MB/s
- Optimizes order of commands with NCQ up to 32 commands

Energy Efficient

- 3.3V low power supply
- Active Mode less than 1,440mW
- Standby Mode less than 325mW
- Sleep Mode less than 15mW
- DevSleep Mode less than 5mW

Pre-programmed Firmware

- Field-upgradeable firmware to add new features and enhance device performance
- Configurable algorithms optimize data retention based on the usage model
- Embedded FFS enables seamless capacity upgrade with no change to host software

Advanced Flash Management

- Dynamic and static wear leveling algorithms maximize product lifespan
- Supports TRIM commands to remove invalid data which is no longer in use

Bad Block Management

- Replaces bad blocks with spare blocks in the NAND flash to prevent uncorrectable errors

Built-in ECC

- Uses advanced LDPC bit error detection and correction optimized for 3D NAND

SSD Lifespan Monitoring

- Supports SMART command-based alerts indicating the remaining useful product life

High Reliability

- MTBF more than 2,000,000 hours

Power Interrupt Data Protection

- Helps prevent data loss during unexpected power failure events

Data Security

- Secure Erase for quick data wipe/factory reset

Full I-temp Capability

- Industrial operation: -40°C to +85°C

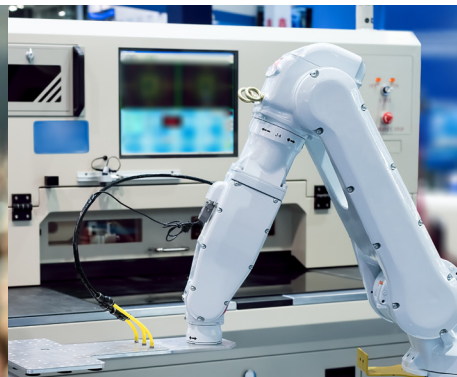

Applications

- Transportation
- Vending machine
- Gaming
- Industrial PC
- Navigation
- Infotainment
- Digital signage
- Point-of-sales
- Security / Surveillance
- Industrial automation & control
- Data logger
- Healthcare
- Test & measurement
- Video conferencing
- Set-top box
- Professional video / photo

Greenliant

3970 Freedom Circle, Suite 100
 Santa Clara, CA 95054 USA
 Tel: 1-408-200-8000
 Fax: 1-408-200-8099

www.Greenliant.com

CFast ArmourDrive Board Diagrams

36.40mm x 42.80mm x 3.60mm
Pb-free (RoHS compliant)

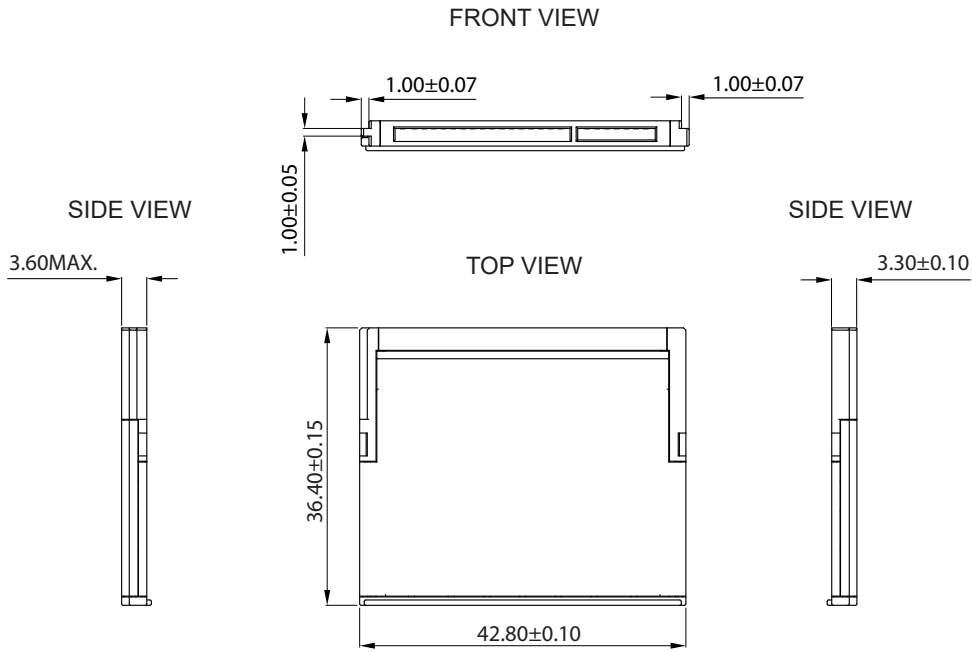

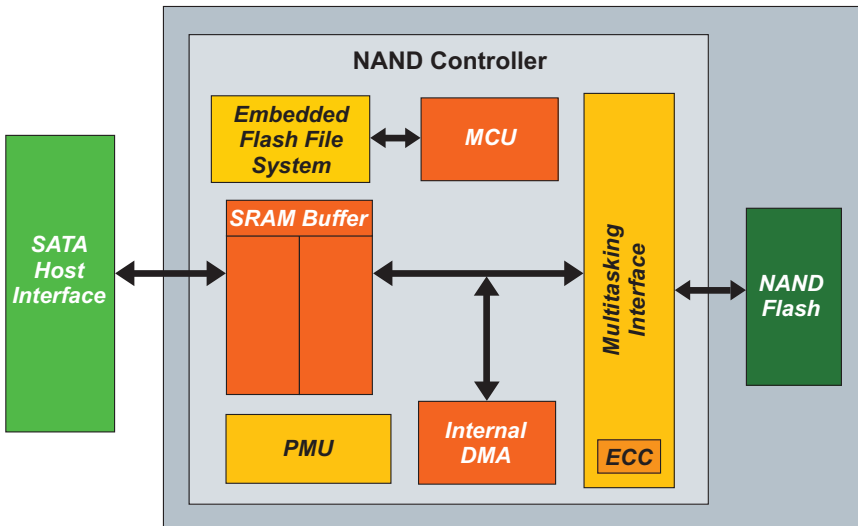

Note: All dimensions are in millimeters, unless otherwise specified.

CFast ArmourDrive Block Diagram



Product Lineup

91 Series CFast ArmourDrive		
Product Series / Capacity	NAND Configuration / Endurance	Temperature Range
PX 64 GB - 256 GB	3-bit-per-cell TLC NAND / 3K P/E cycles	Industrial -40°C to +85°C

 twitter.com/Greenliant
 linkedin.com/company/Greenliant-Systems
 facebook.com/Greenliant

ArmourDrive FAQs: www.greenliant.com/armourdrive-faqs

For more information, contact your Greenliant representative: www.greenliant.com/sales



© 2021 Greenliant
Greenliant, the Greenliant logo and ArmourDrive are trademarks of Greenliant.
These specifications are subject to change without notice. 10/2021