

# GP1S173LCS2F

Gap : 5.0mm Slit : 0.5mm  
Phototransistor Output,  
Compact Transmissive  
Photointerrupter with connector

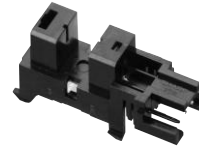

## ■Description

**GP1S173LCS2F** is a standard, phototransistor output, transmissive photointerrupter with opposing emitter and detector in a case, providing non-contact sensing. For this family of devices, the emitter and detector are inserted in a case, and a 3-pin connector is included to allow remote-mount or off-board designs.

## ■Agency approvals/Compliance

1. Compliant with RoHS directive (2002/95/EC)

## ■Applications

1. General purpose detection of object presence or motion.  
Example : PPC, FAX, Printer

## ■Features

1. Transmissive with phototransistor output
2. Highlights :
  - Special position hooks compatible with 3 different Plate thicknesses (1.0, 1.2, 1.6mm)
  - Snap insertion
3. Key Parameters :
  - Gap Width : 5mm
  - Slit Width (detector side) : 0.5mm
  - Package : 17 × 12.8 × 8mm (without connector and hooks)
  - Connector : Tyco Electronics JAPAN G.K. (173977-3 and 179228-3)
4. RoHS directive compliant

Notice The content of data sheet is subject to change without prior notice.  
In the absence of confirmation by device specification sheets, SHARP takes no responsibility for any defects that may occur in equipment using any SHARP devices shown in catalogs, data books, etc. Contact SHARP in order to obtain the latest device specification sheets before using any SHARP device.

Sheet No.: OP13014EN

■ Internal Connection Diagram

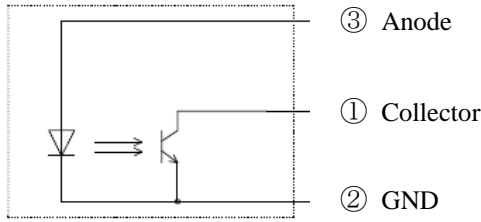

■ Outline

Drawing No. CY14032i02A

Scale : 2/1 Unit : 1/1 mm

- Note) 1. Unspecified tolerance shall be followed the list below.  
 2. Dimensions in parenthesis are shown for reference.  
 3. Coupling and contact : CT receptacle connector (173977-3 and 179228-3) by Tyco Electronics Japan G.K.  
 4. Date code  
 Y : Year (2012 : 2) Number of the end of the Christian era  
 M : Month (1-9, X, Y, Z)  
 D : Date (1-9, Please refer to a right list other than it.)

Date	10	11	12	13	14
Code	A	B	C	D	E
Date	15	16	17	18	19
Code	F	G	H	J	K
Date	20	21	22	23	24
Code	M	N	O	P	R
Date	25	26	27	28	29
Code	S	T	U	W	X
Date	30	31			
Code	Y	Z			

Dimension	Tolerance
less than 5.0	±0.15
5.0 or more less than 15.0	±0.2
15.0 or more	±0.3

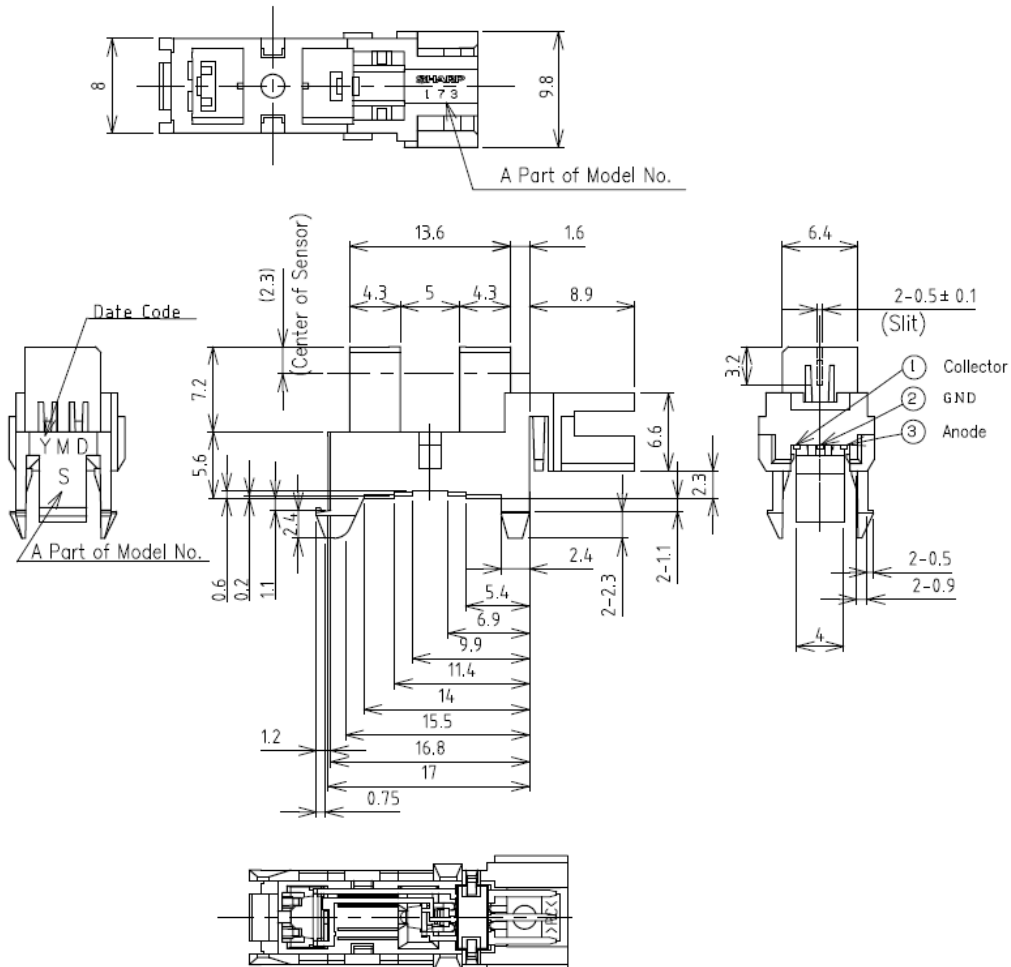

■ **Absolute maximum ratings**

Ta=25°C

Parameter		Symbol	Rating	Unit
Input	*1 Forward current	$I_F$	50	mA
	*1, 2 Peak forward current	$I_{FM}$	1	A
	Reverse voltage	$V_R$	5	V
	Power dissipation	P	75	mW
Output	Collector-emitter voltage	$V_{CEO}$	35	V
	Emitter-collector voltage	$V_{ECO}$	6	V
	Collector current	$I_c$	20	mA
	*1 Collector power dissipation	$P_c$	75	mW
*3 Operating temperature		Topr	-30 to +95	°C
Storage temperature		Tstg	-40 to +100	°C

\*1 The derating factors of absolute maximum ratings due to ambient temperature are shown in Fig. 1, 2, 3.

\*2 Pulse width  $\leq 100\mu s$ , Duty ratio : 0.01

\*3 Connector attachment and release shall be done at normal temperature.

■ **Electro-optical Characteristics**

Ta=25°C

Parameter		Symbol	Conditions	MIN.	TYP.	MAX.	Unit
Input	Forward voltage	$V_F$	$I_F=20mA$	-	1.2	1.4	V
	Peak forward voltage	$V_{FM}$	$I_{FM}=0.5A$	-	2	3	V
	Reverse current	$I_R$	$V_R=3V$	-	-	5	$\mu A$
Output	Dark current	$I_{CEO}$	$V_{CE}=20V$	-	-	100	nA
Transfer characteristics	Collector current	$I_c$	$V_{CE}=5V, I_F=20mA$	0.5	-	15	mA
	Collector-emitter saturation voltage	$V_{CE(sat)}$	$I_F=40mA, I_c=0.5mA$	-	-	0.4	V
	Response time	(Rise)	tr	$V_{CE}=2V, I_c=2mA$ $R_L=100\Omega$	-	3	15
(Fall)		tf	-		4	20	$\mu s$

(Test circuit for response time)

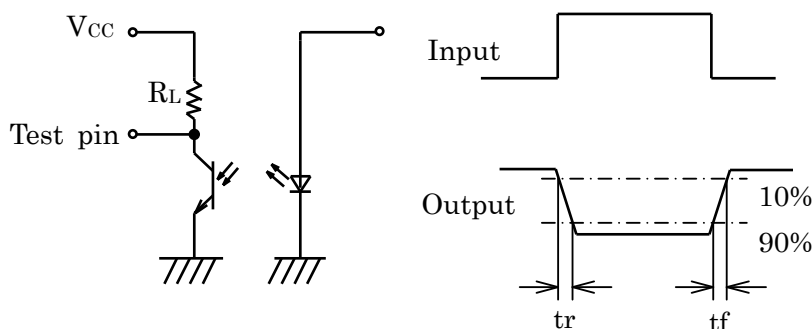

Fig.1 Forward current vs. ambient temperature

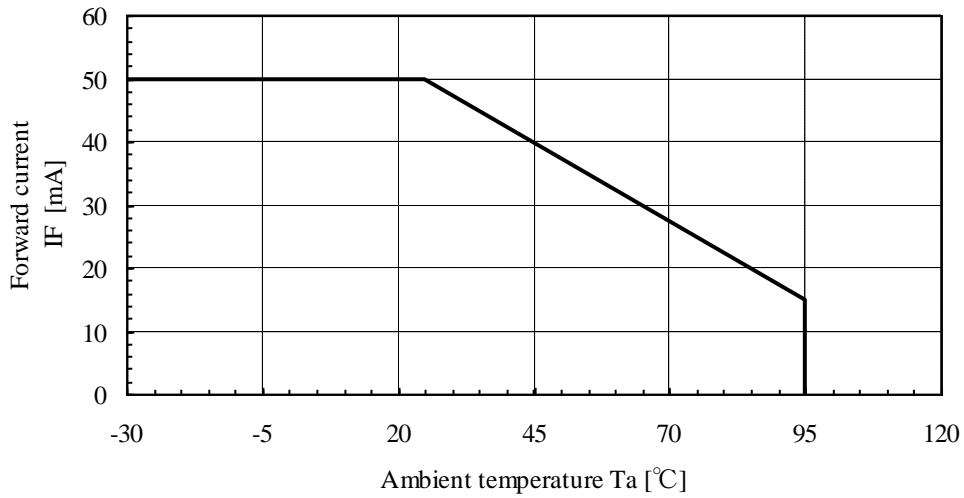

Fig.2 Collector power dissipation vs. ambient temperature

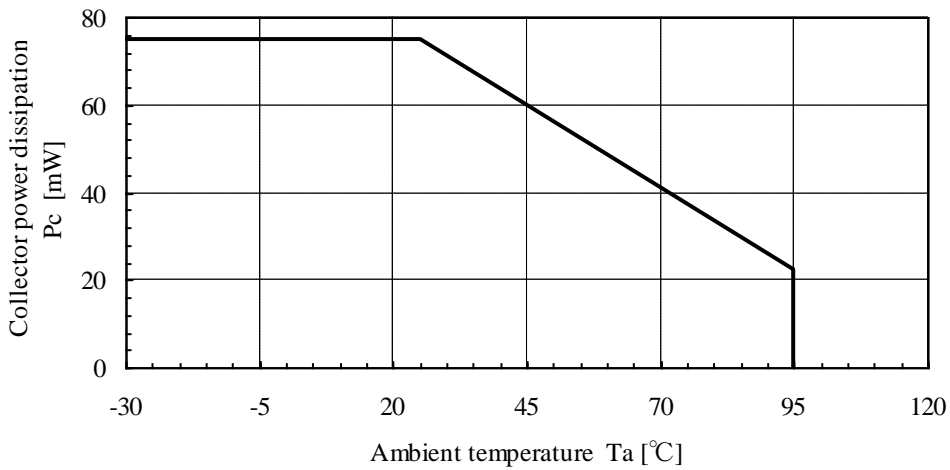
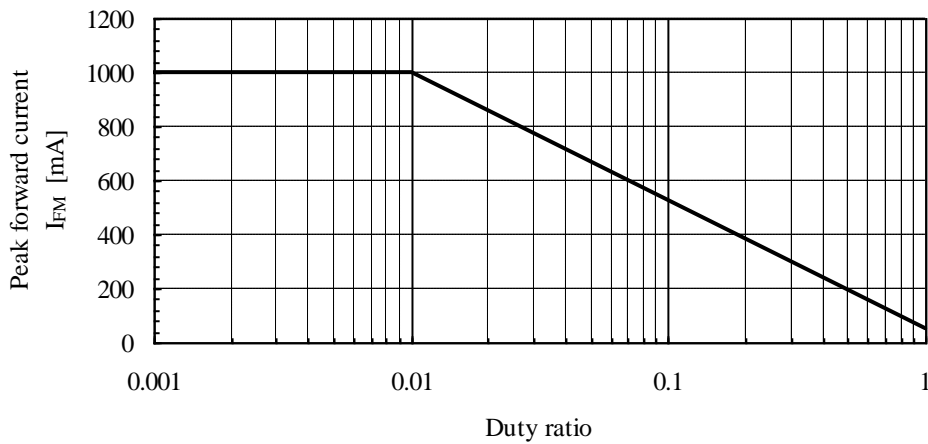

Fig.3 Peak forward current vs. duty ratio

Pulse width  $\leq 100\mu s$  Ta=25°C



■ **Supplements**

● ODS materials

This product shall not contain the following materials.

Also, the following materials shall not be used in the production process for this product.

Materials for ODS : CFCs, Halon, Carbon tetrachloride 1.1.1-Trichloroethane (Methyl chloroform)

● Specified brominated flame retardants

Specified brominated flame retardants (PBB and PBDE) are not used in this device at all.

● Country of origin : Philippine or China

● Product mass : Approx. 1.0g

● Compliance with each regulation

1) The RoHS directive(2002/95/EC)

This product complies with the RoHS directive(2002/95/EC).

Object substances: mercury, lead, cadmium, hexavalent chromium, polybrominated biphenyls (PBB) and polybrominated diphenyl ethers (PBDE)

2) Content of six substances specified in Management Methods for Control of Pollution Caused by Electronic Information Products Regulation (Chinese : 电子信息产品污染控制管理办法).

Category	Toxic and hazardous substances					
	Lead (Pb)	Mercury (Hg)	Cadmium (Cd)	Hexavalent chromium (Cr <sup>6+</sup> )	Polybrominated biphenyls (PBB)	Polybrominated diphenyl ethers (PBDE)
Photointerrupter	✓	✓	✓	✓	✓	✓

✓ : indicates that the content of the toxic and hazardous substance in all the homogeneous materials of the part is below the concentration limit requirement as described in SJ/T 11363-2006 standard.

**■Notes**

## ●Circuit design

In circuit designing, make allowance for the degradation of the light emitting diode output that results from long continuous operation. (50% degradation/5 years)

## ●Position of opaque board

Opaque board shall be installed at place 4mm or more from the top of elements.

(Example)

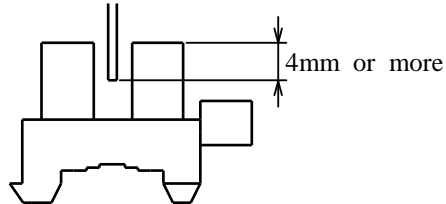

In case opaque board is the material with an low light blocking effect, There is a possibility of malfunctioning because the light of LED transmits the opaque board. When you design the opaque board, please note transmittance of infrared rays wave length (940nm) and the thickness of the opaque board.

And, please adjust the amount of transmitted light to 0.1% or less.

## ●Cleaning

Please don't carry out immersion cleaning or ultrasonic cleaning to avoid keeping solvent inside case of this device.

## ●Washing material

Dust and stain shall clean by air blow, or shall clean by soft cloth soaked in washing materials.

And washing material to clean shall be used the below materials only.

Ethyl alcohol, Methyl alcohol, Isopropyl alcohol

## ●Connector connection

For the electrical connection to the connector terminal, please certainly use the connector specified in this specifications.

Please avoid the connection by the soldering or welding which may damage the main body of the device, and also avoid the contact by the clip and so on which may cause the malfunction by the contact failure.

Please avoid the use condition that it always occurs the vibration in the spot where the connector fits in by the resonance of the sensor and the harness.

It may cause the malfunction of the contact failure.

## ●Put-in and pull-out of connector

The connection other than to the correct connection direction, forcing-into, and the pulling-out diagonally (if being not put-in and pulled-out straight) may deform or break the connector terminal and/or housing, which may cause the unusable state of the device.

**Recommended Installation Hole drawing**

Scale : 2/1 Unit : 1/1mm

(Drawing No. CY14033i06)

- \*1 We recommend to fix GP1S173LCS2F at punching side on the fixing plate (metal plate).
- \*2 Please decide the final dimensions at your side after confirmation by the actual applications, Because mounting efficiency and mounted stabilization are dependent on mounting plate corner-R and punched state.
- \*3 Tolerance shall be  $\pm 0.1$ mm
- \*4 Please don't hold connector area but sensor area when fitting in or putting out on the metal plate.

Normal mounting type

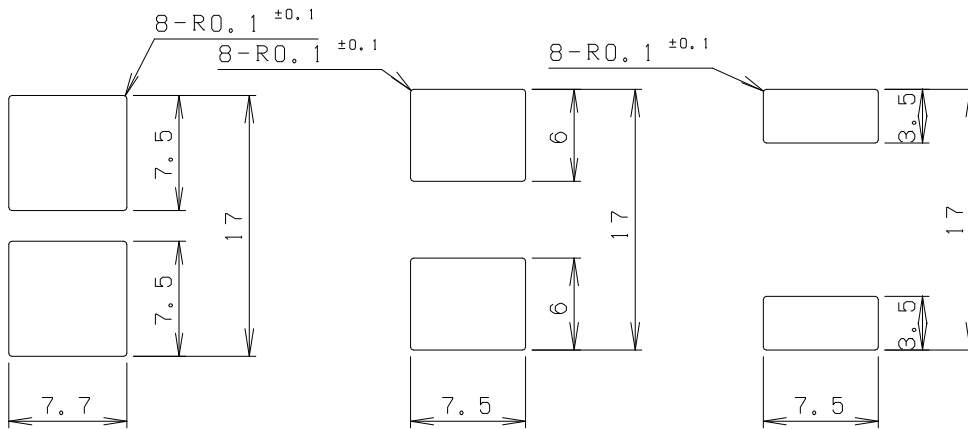

Thickness of plate for 1.6mm

Thickness of plate for 1.2mm

Thickness of plate for 1.0mm

Irregular mounting protection type

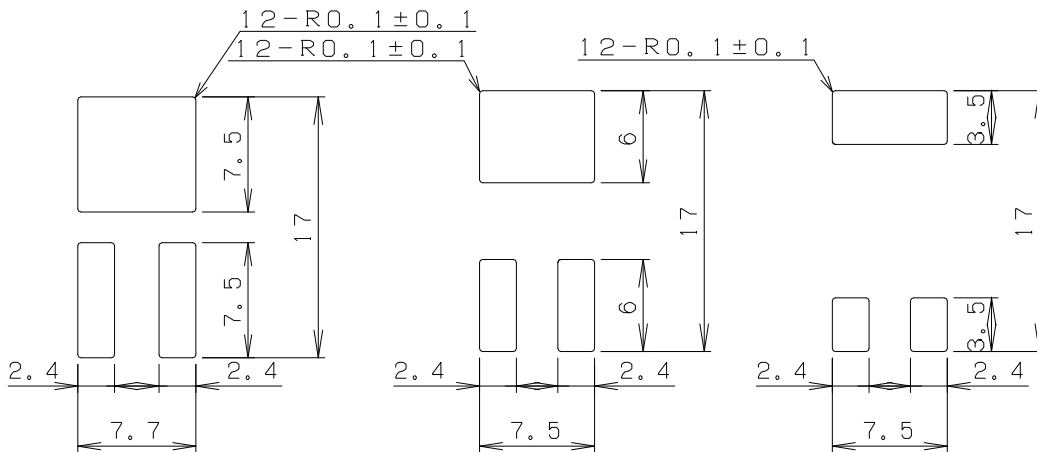

Thickness of plate for 1.6mm

Thickness of plate for 1.2mm

Thickness of plate for 1.0mm

■ **Parts**

This product uses the following parts.

● Light detector (Quantity : 1)

Type	Material	Maximum sensitivity wavelength (nm)	Sensitivity wavelength (nm)	Response time (μs)
Phototransistor	Silicon (Si)	930	400 to 1200	3

● Light emitter (Quantity : 1)

Type	Material	Maximum light emitting wavelength (nm)	I/O Frequency (MHz)
Infrared light emitting diode (non-coherent)	GaAs	940	0.3

● Material

Case	Lead flame
Black polycarbonate resin (UL 94V-0)	Copper Alloy (With plating)

● Others

- This product shall not be radiation flux proof.
- The laser oscillator is not equipped on this product.
- The terminals are covered with Tin Plating (more than 99.99%).



■ Packing specification

● Package

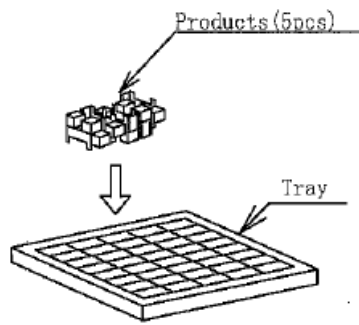

<Fig 1>

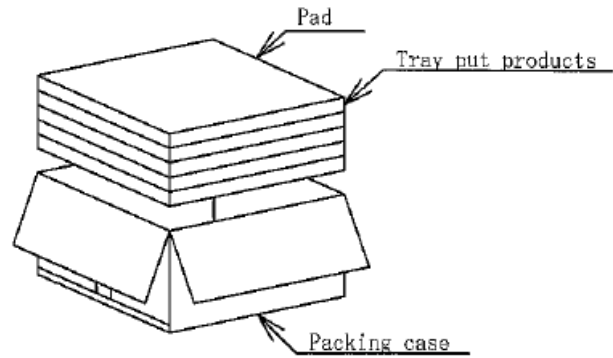

<Fig 2>

No.	Name	Material	Quantity
1	Packing case	Corrugated cardboard	1/1000
2	Pad	Corrugated cardboard	6/1000
3	Tray	Polystyrene	1/200
4	Kraft tape		-

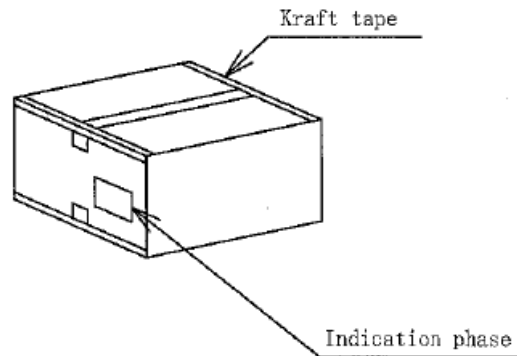

<Fig 3>

● Packing method

- 1) 5 products are put in 1 pocket.  
The longer direction of the product is arranged in the arbitrary direction.  
200 products are put in the tray. <Fig.1>
- 2) The pads are attached at the top and the bottom of the trays and also inserted between the trays. <Fig.2>
- 3) Seal packing case with Kraft tape. <Fig.3>
- 4) Indication phase items  
The contents of the carton indication conforms to EIAJ C-3 and the following items are indicated.  
Model No., Internal production control name, Quantity, Packing date, Corporate name,  
Country of origin <Fig.3>  
(1000pcs. / packing case)  
(Approximately 2.26kg / packing mass)