



Product Description

GRF2100 is a high-gain, low-current LNA tunable over 100 to 3800 MHz. It exhibits outstanding gain and NF with I_{DDQ} levels as low as 8 mA.

The device is operated from a supply voltage (V_{DD}) of 1.8 to 5.0 V with a selectable I_{DDQ} range of 8 to 30 mA for optimal efficiency and linearity.

Consult with the GRF applications engineering team for custom tuning/evaluation board data and device s-parameters.

Features

Reference: 3.3V/15mA/2500 MHz

- EVB NF: 0.80 dB
- Gain: 16.5 dB
- OP1dB: 10.0 dBm
- OIP3: 19.0
- Flexible Bias Voltage and Current
- Process: GaAs pHEMT

Applications

- ISM LNA
- 2.4 GHz Drones
- Small Cells and Cellular Repeaters
- Distributed Antenna Systems

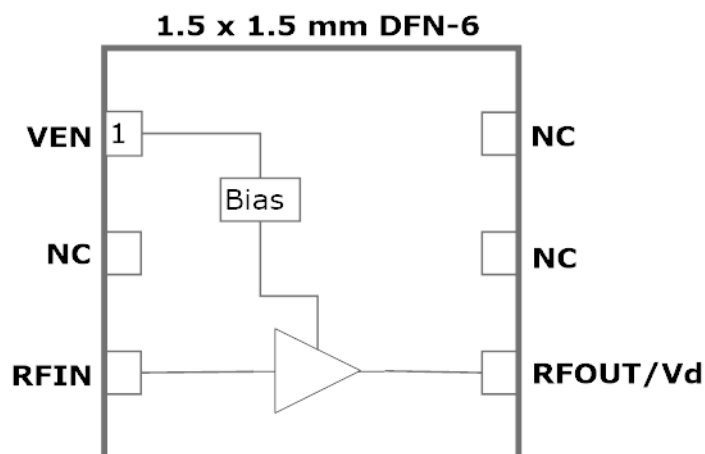

Absolute Ratings:

Parameter	Symbol	Min.	Max.	Unit
Supply Voltage	V _{DD}	0	5.5	V
RF Input Power: (Load VSWR < 2:1; V _D : 5.0 volts)	P _{IN MAX}		15	dBm
Operating Temperature (Package Heat Sink)	T _{AMB}	-40	105	°C
Maximum Channel Temperature (MTF > 10 ⁶ Hours)	T _{MAX}		170	°C
Maximum Dissipated Power	P _{DISS MAX}		150	mW
Electrostatic Discharge:				
Charged Device Model:	CDM	1500		V
Human Body Model:	HBM	250		V
Storage:				
Storage Temperature	T _{STG}	-65	150	°C
Moisture Sensitivity Level	MSL		1	--



Caution! ESD Sensitive Device



Exceeding Absolute Maximum Rating conditions may cause permanent damage to the device.

Note: For manufacturing information, see the Guerrilla-RF.com website for the following document located on the GRF2100 landing page: **Manufacturing Note—MN-001 Product Tape and Reel, Solderability and Package Outline Specification.**

[Link to manufacturing note](#)

Pin Out (Top View)



Pin Assignments:

Pin	Name	Description	Note
1	V_{ENABLE}	Enable Voltage Input	V _{ENABLE} and series resistor set I _{DDQ} . V _{ENABLE} < =0.2 volts disables device. On -die pull-down resistor will turn the part off if this node is allowed to float.
2	NC	No Connect or Ground	No internal connection to die
3	RF_In	LNA RF input	An external DC blocking cap must be used
4	RF_Out	LNA RF output	V _{DD} must be applied through a choke to this pin
5	NC	No Connect or Ground	No internal connection to die
6	NC	No Connect or Ground	No internal connection to die
PKG BASE	GND	Ground	Provides DC and RF ground for LNA, as well as thermal heat sink. Recommend multiple 8 mil vias beneath the package for optimal RF and thermal performance. Refer to evaluation board top layer graphic on schematic page.



Released

GRF2100

Low-current LNA
0.1–3.8 GHz

Nominal Operating Parameters:

Parameter	Symbol	Specification			Unit	Condition
		Min.	Typ.	Max.		
Test Frequency	F _{TEST}		2500		MHz	V _{DD} = 3.3 V, T _A = 25 °C
Gain	S ₂₁	15.0	16.5		dB	
Evaluation Board Noise Figure	NF		0.80	1.0	dB	
Output 3rd Order Intercept	OIP ₃		19.0		dBm	-5.0 dBm P _{OUT} per tone at 2 MHz Spacing (2499 and 2501 MHz)
Output 1dB Compression Point	OP _{1dB}	8.0	10.0		dBm	
Switching Rise Time	T _{RISE}		800		ns	
Switching Fall Time	T _{FALL}		200		ns	
Supply Current	I _{DD}		15	21	mA	V _{DD} = V _{ENABLE} = 3.3 V; R _{bias} : 6.0k Ω
Enable Current	I _{ENABLE}		0.5		mA	
Disabled Mode						
Leakage Current	I _{LEAKAGE}		<1		uA	V _{DD} : 3.3V; V _{ENABLE} : 0.0V
Thermal Data						
Thermal Resistance: (Estimated)	Θ _{JC}		300		°C/W	On standard Evaluation Board
Channel Temperature @ +85 C Reference (Package heat sink)	T _{CHANNEL}		100 (See note)		°C	V _{DD} : 3.3V; I _{DDQ} : 15 mA; No RF; P _{DISS} : 50 mW

Note: MTTF >10⁶ hours for T_{CHANNEL} < =170 degrees C.

GRF2100 Evaluation Board Measured Data; (3.3V/15mA)

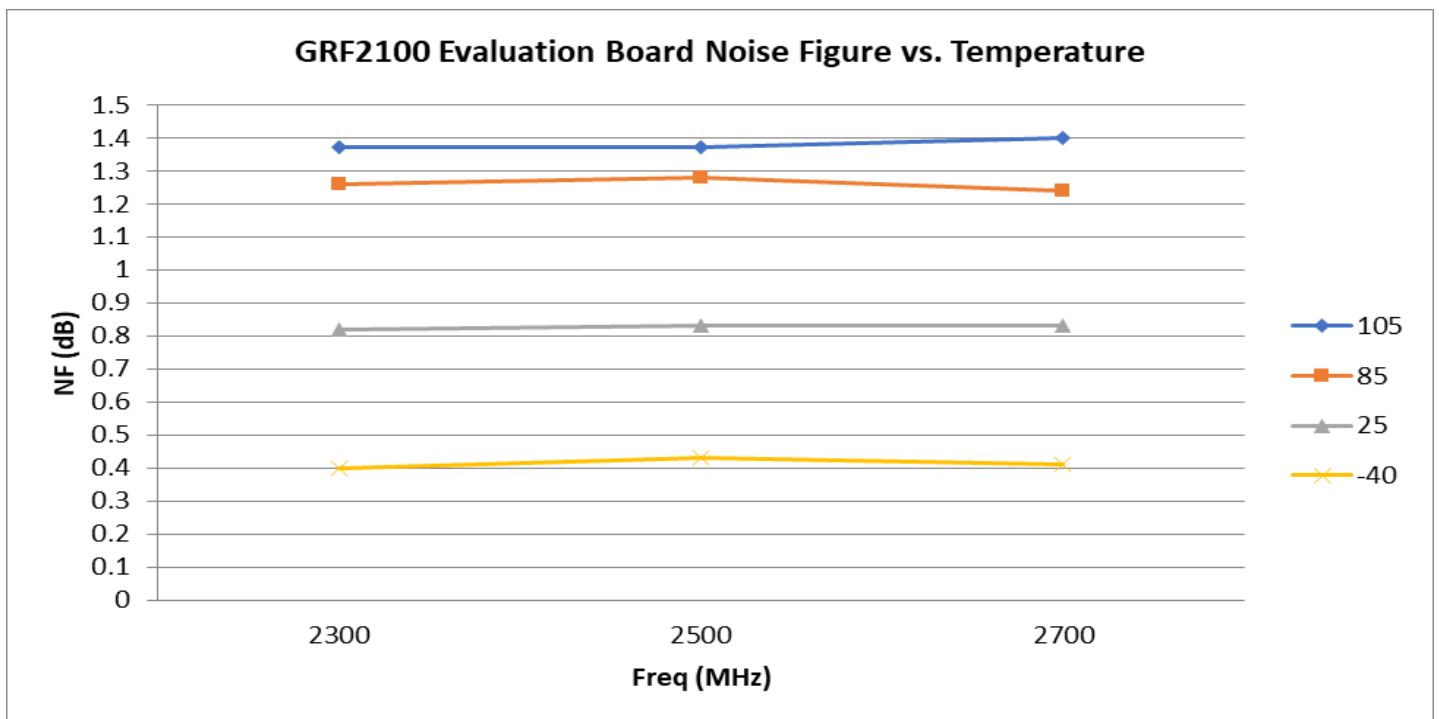
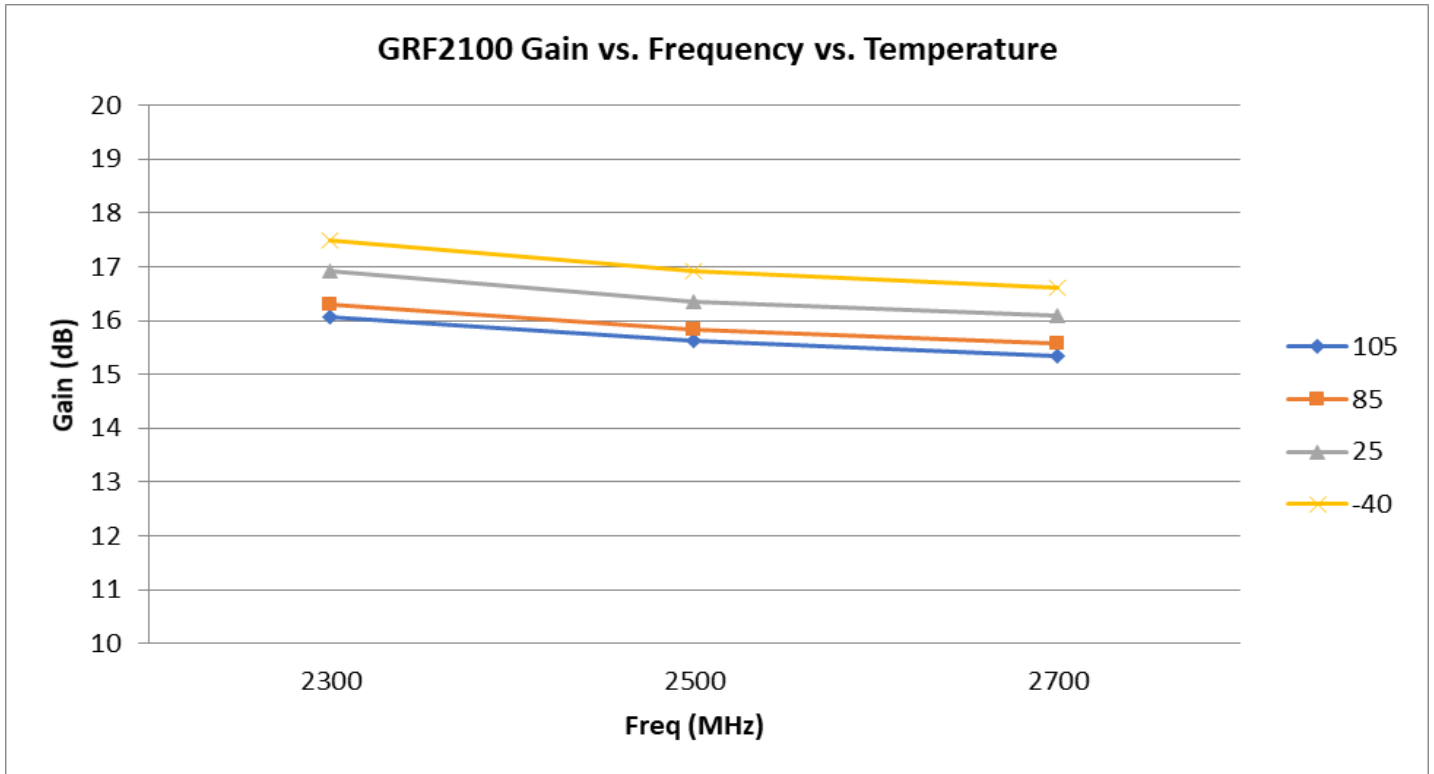

GRF2100 Evaluation Board Measured Data; (3.3V/15mA)

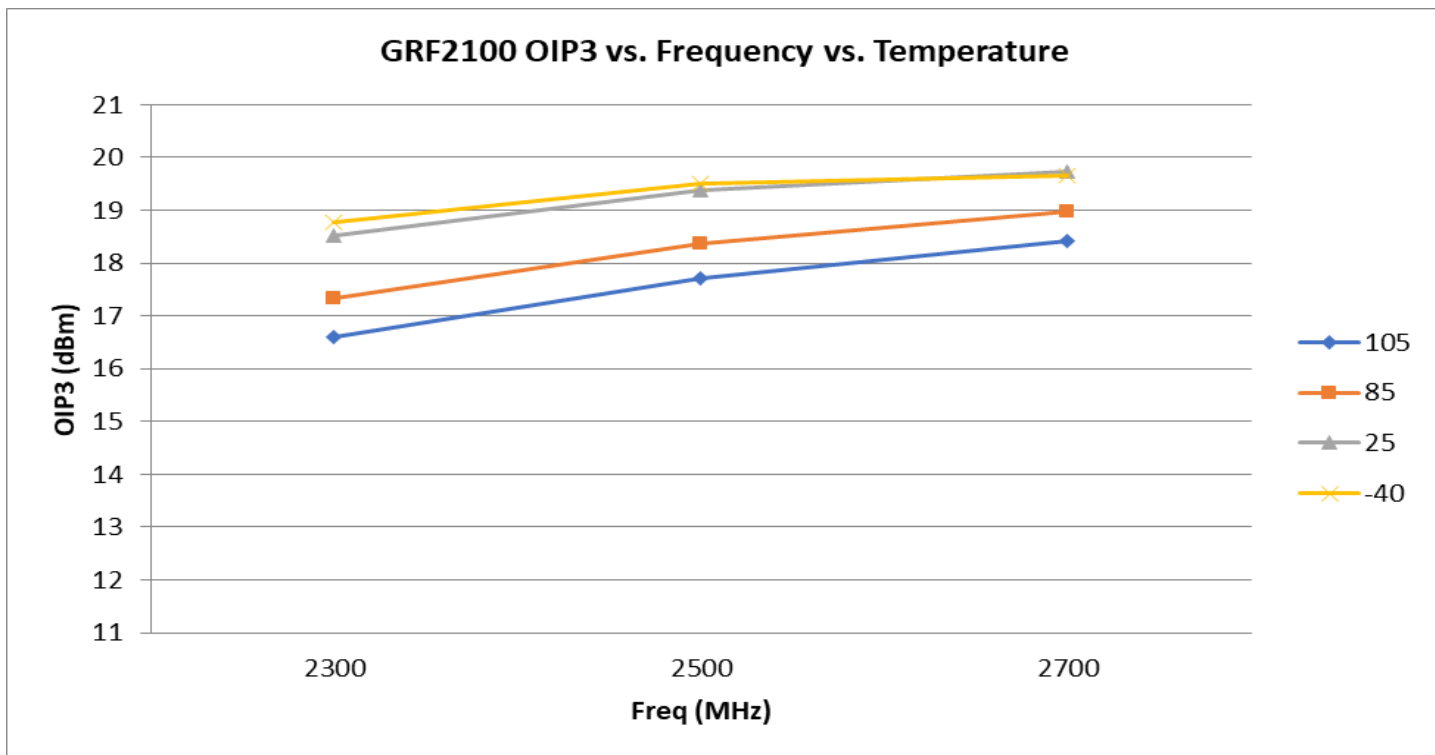
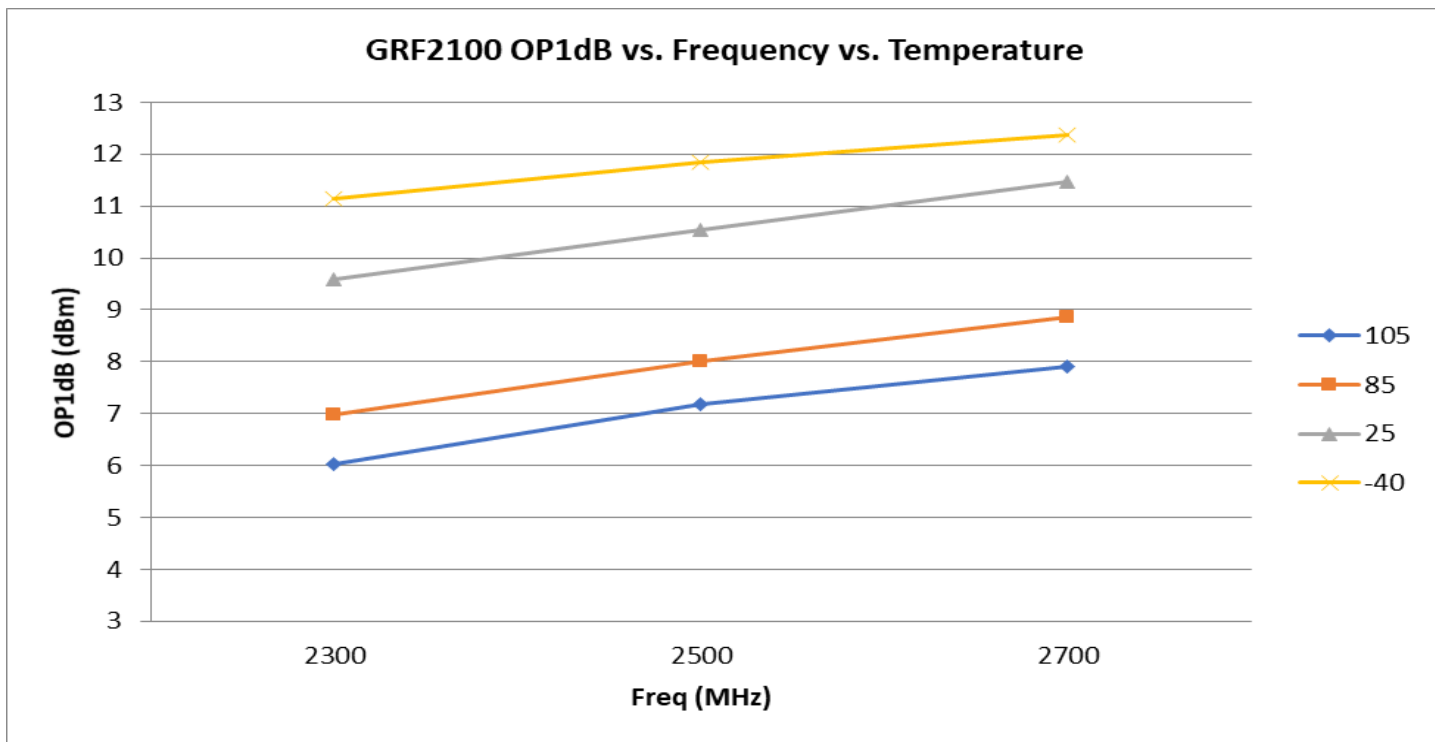

GRF2100 Evaluation Board S-Pars and Stability Mu Factor: (2.4 to 2.7 GHz Match)

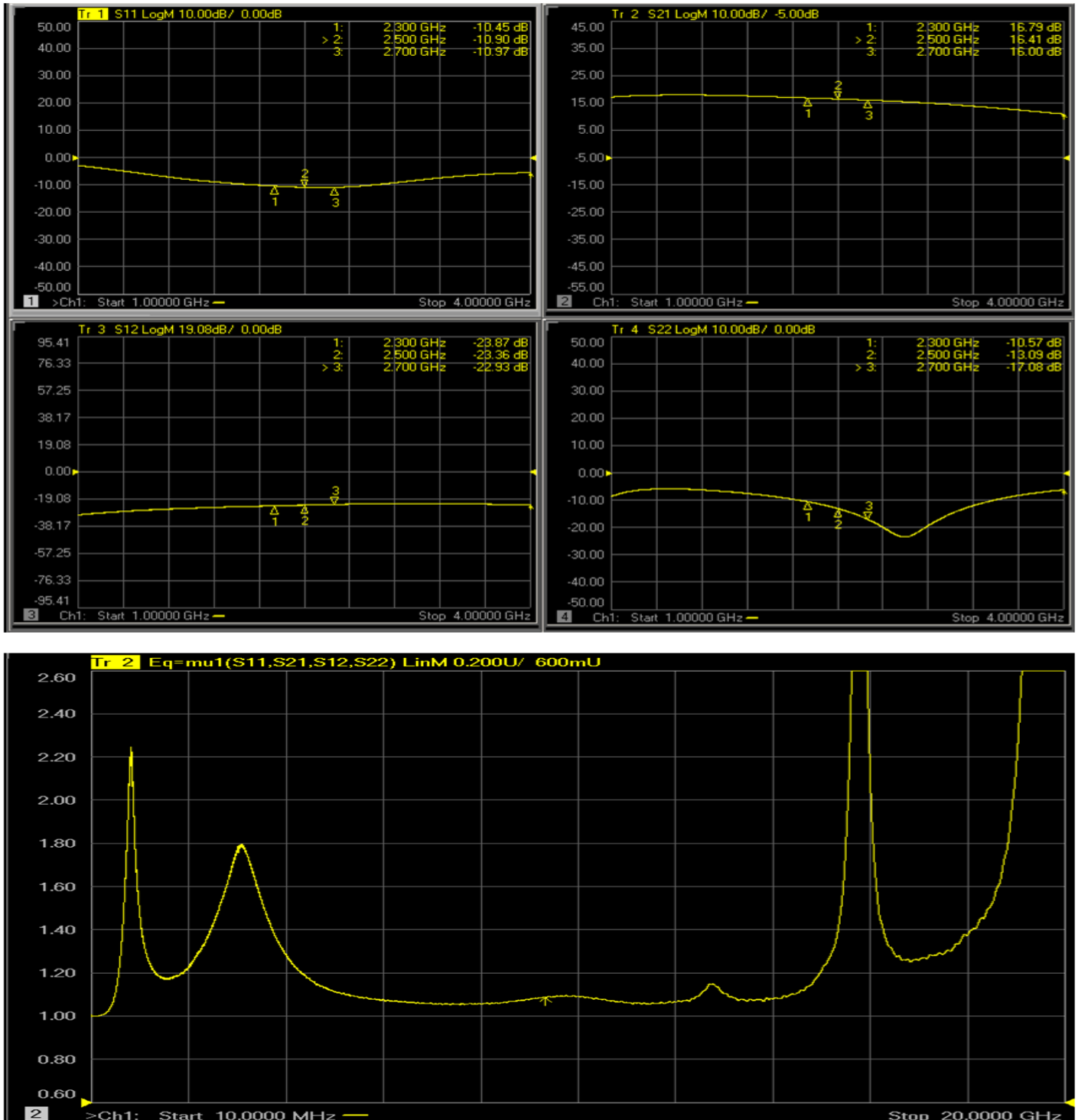

Note: Mu factor ≥ 1.0 implies unconditional stability.

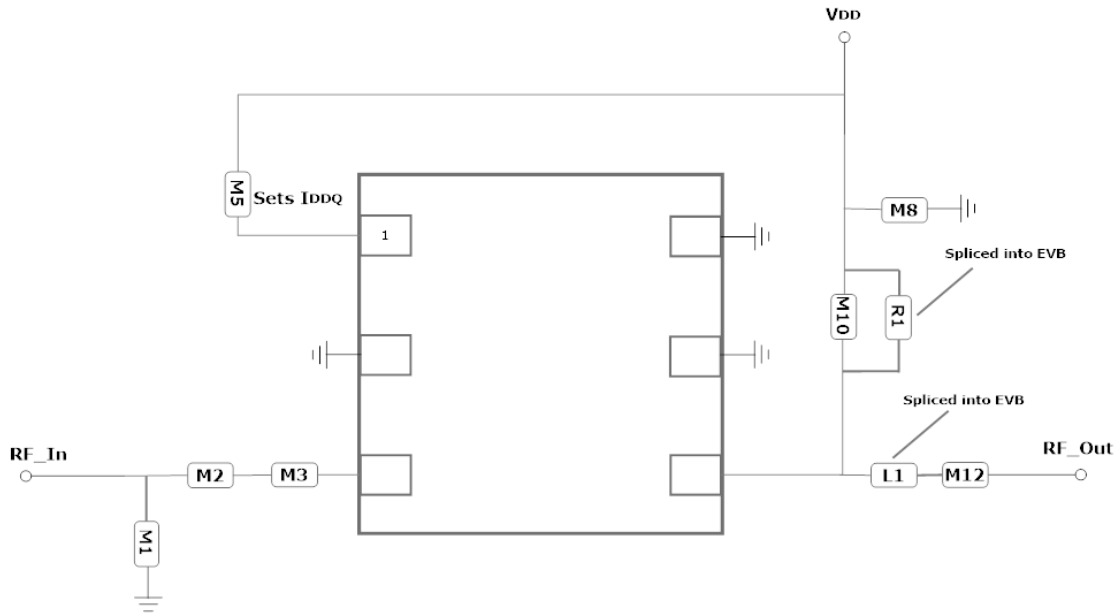

GRF2100 Application Schematic

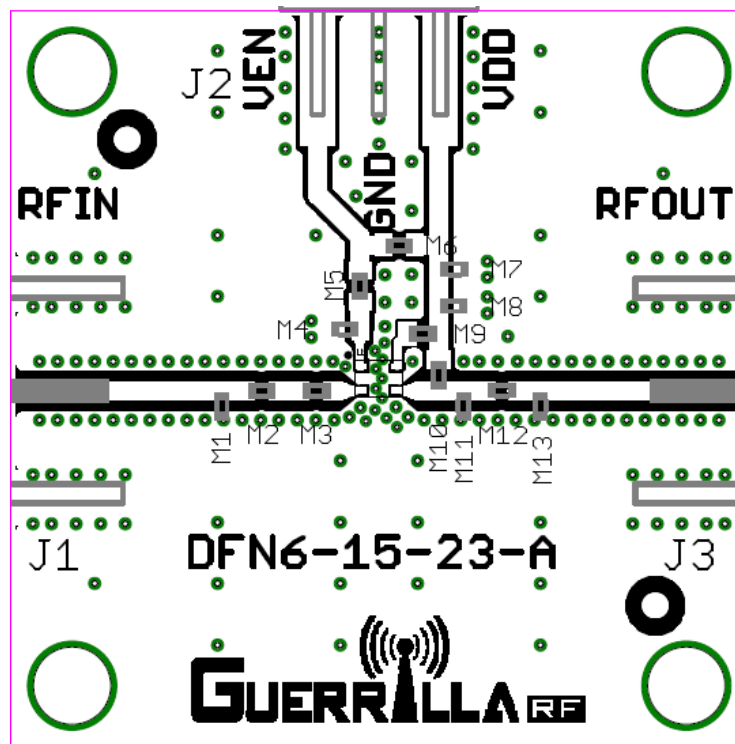

GRF2100 Evaluation Board Assembly Diagram



Released

GRF2100

Low-current LNA
0.1–3.8 GHz

GRF2100 Standard Evaluation Board BOM: (2.4 to 2.7 GHz Tune; $V_{dd} = V_{enable} = 3.3V$; $I_{ddq} = 15\text{ mA}$)

Component	Type	Manufacturer	Family	Value	Package Size	Substitution
M1	Inductor	Murata	LQP	6.2nH	0402	Ok
M2	Capacitor	Murata	GJM	8.2 pF	0402	Ok
M3	Inductor	Murata	LQP	2.0 nH	0402	Ok
M5 (Sets I_{ddq})	Resistor	Various	5%	6.0k ohms	0402	Ok
M8	Capacitor	Murata	GRM	0.1 uF	0402	Ok
M10	Inductor	Murata	LQG	10 nH	0402	Ok
R1	Resistor	Various	5%	370 ohms	0402	Ok
L1	Inductor	Murata	LQP	3.0 nH	0402	Ok
M12	Capacitor	Murata	GJM/GRM	2.7 pF	0402	Ok
Evaluation Board	DFN6-15-23-A (modified for inclusion of L1 and R1)	—	—	—	—	—

GRF2100 w/ $V_{dd} = 3.3V$: Required Bias R @ V_{enable} vs. I_{ddq}

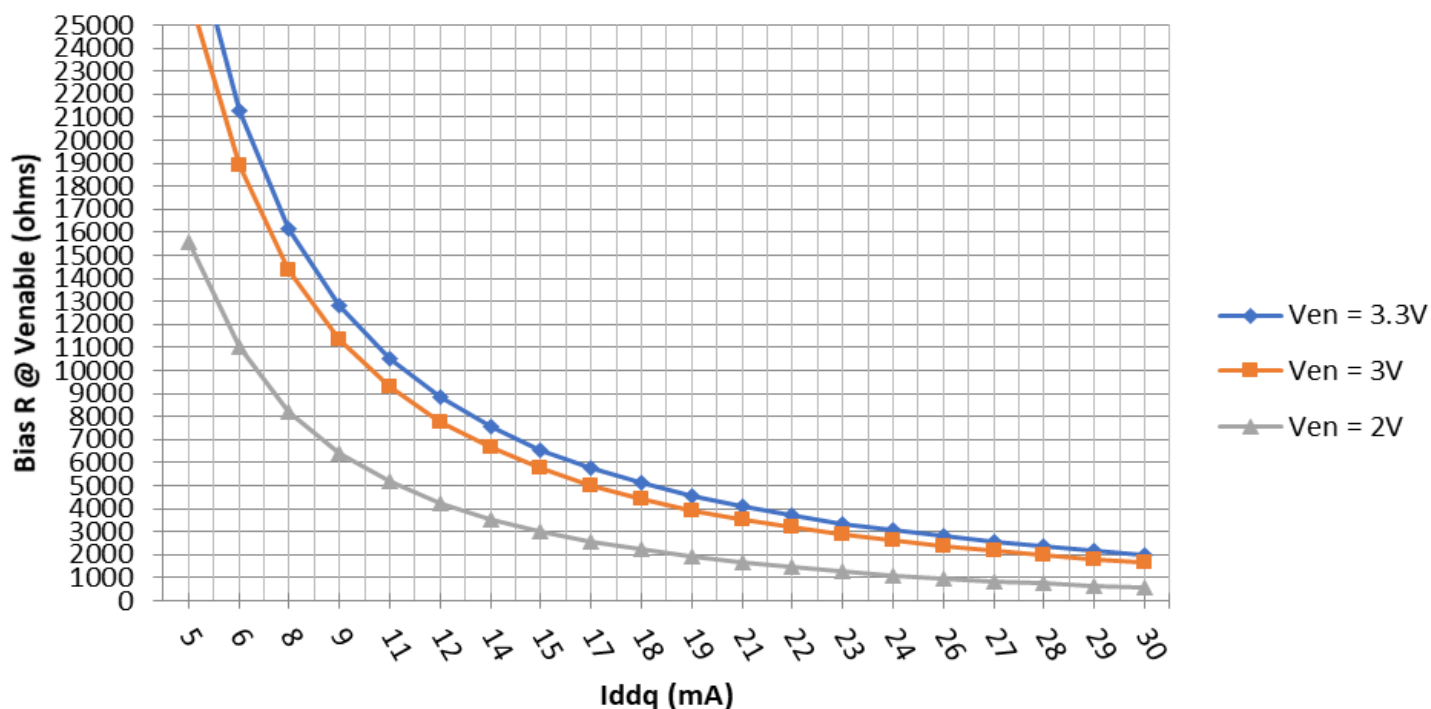

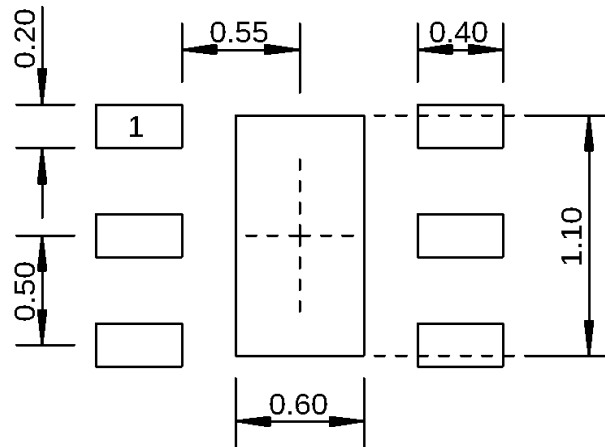

Dimensions in millimeters

1.5 mm DFN-6 Suggested PCB Footprint (Top View)

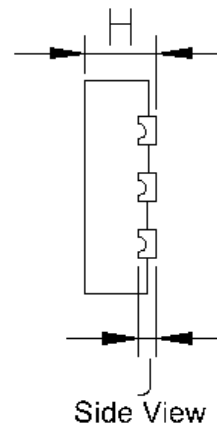
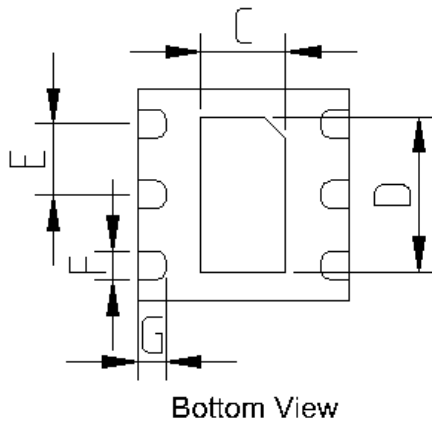
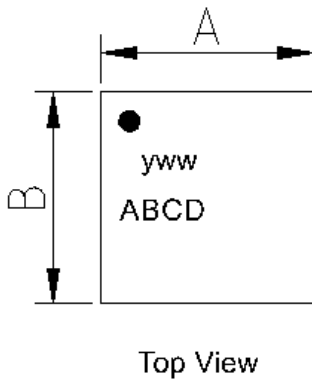

Dimensions (MM)	
A	1.5 +/- 0.050
B	1.5 +/- 0.050
C	.6 +/- 0.050
D	1.1 +/- 0.050
E	.5 Bsc
F	.2 +/- 0.050
G	.2 +/- 0.050
H	.45 +/- 0.050
J	.12 Ref.

1.5 mm DFN-6 Package Dimensions

Tape and Reel Information:

Guerrilla RF’s Tape and Reel specification complies with the Electronics Industries Association (EIA) standards for ‘Embossed Carrier Tape of Surface Mount Components for Automatic Handling’. Reference EIA-481. See the table on the following page for Tape and Reel specifications along with units per reel.

Devices are loaded with pins down into the carrier pocket with protective cover tape, wound into a plastic reel. Each reel will be packaged in a cardboard box. There will be product labels on the reel, the protective ESD bag and the outside surface of the box.

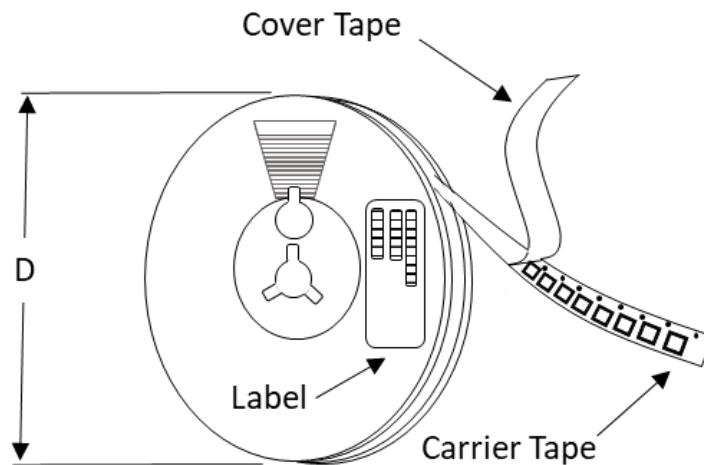

Tape and Reel Packaging with Reel Diameter Noted (D)

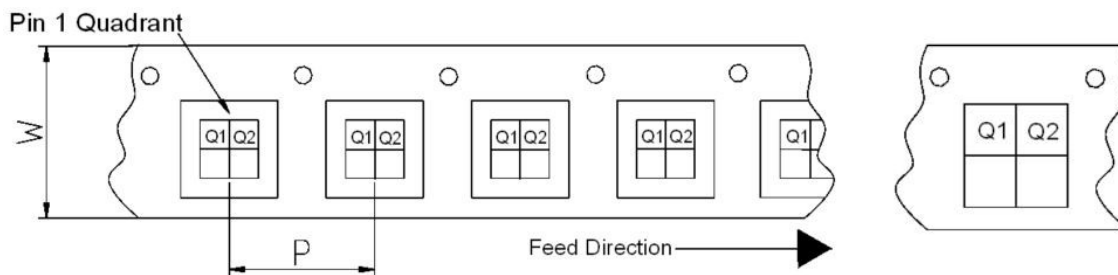

Carrier Tape Width (W), Pitch (P), Feed Direction and Pin 1 Quadrant Information



Released

GRF2100

Low-current LNA
0.1–3.8 GHz

Tape and Reel Specification and Device Package Information Table

Package				Carrier Tape			Reel	
Type	Dimensions (mm)	Leads	Weight (mg)	Width (W) (mm)	Pocket Pitch (P) (mm)	Pin 1 Quadrant	Diameter (D) (inches)	Units per Reel
QFN	2.0 x 2.0 x 0.50	12	7	8	4	Q1	7	2500
QFN	3.0 x 3.0 x 0.85	16	24	12	8	Q1	7	1500
DFN	1.5 x 1.5 x 0.45	6	4	8	4	Q1	7	2500
DFN	2.0 x 2.0 x 0.75	8	12	8	4	Q1	7	2500
LFM	3.5 x 3.5 x 0.75	See	TBD	12	8	Q2	7	1500
LFM	4.0 x 4.0 x 0.75	See note	TBD	12	8	Q2	7	1500

Note: Lead count may vary. Reference applicable product data sheet