



Product Description

GRF2101 is an ultra-low noise amplifier (LNA) designed for IEEE 802.11a/n/ac/p applications (5.1 GHz to 5.925 GHz). Over this band, the device exhibits outstanding evaluation board noise figure (NF) of 0.90 dB. The high gain, superior NF and directivity of its design allows designers to create receiver architectures with outstanding cascaded NF and unconditional stability.

The device can also be tuned up to 10 GHz delivering high gain and low NF.

The LNA is operated from a single positive supply of 2.7 to 5.0 V with a typical bias condition of 3.3 V and 18 mA.

Consult with the GRF applications engineering team for custom tuning/evaluation board data and device s-parameters.

Features

Reference: 3.3V/18mA/5.5 GHz

- Evaluation Board NF: 0.90 dB
- Gain: 18.0 dB
- OP1dB: 10.0 dBm
- OIP3: 22.0 dBm

- Flexible Bias Voltage and Current
- Process: GaAs pHEMT

Applications

- WiFi Access Points
- Mobile WiFi Devices
- 802.11p Vehicle Communications
- Microwave Backhaul

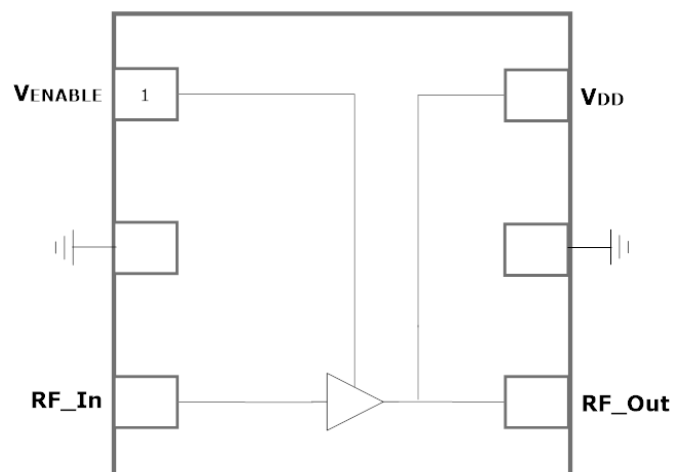

Absolute Ratings:

Parameter	Symbol	Min.	Max.	Unit
Supply Voltage	V _{DD}	0	6.0	V
RF Input Power: (Load VSWR < 2:1; V _D : 5.0 volts)	P _{IN MAX}		20	dBm
Operating Temperature (Package Heat Sink)	T _{AMB}	-40	105	°C
Maximum Channel Temperature (MTTF > 10 ⁶ Hours)	T _{MAX}		170	°C
Maximum Dissipated Power	P _{DISS MAX}		200	mW
Electrostatic Discharge:				
Charged Device Model:	CDM	TBD		V
Human Body Model:	HBM	TBD		V
Storage:				
Storage Temperature	T _{STG}	-65	150	°C
Moisture Sensitivity Level	MSL		1	--

Caution! ESD Sensitive Device



Exceeding Absolute Maximum Rating conditions may cause permanent damage to the device.

Note: For manufacturing information, see the Guerrilla-RF.com website for the following document located on the GRF2101 landing page: Manufacturing Note—MN-001 Product Tape and Reel, Solderability and Package Outline Specification.

[Link to manufacturing note](#)

Pin Out (Top View)

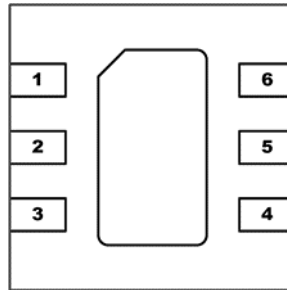

Pin Assignments:

Pin	Name	Description	Note
1	V_{ENABLE}	LNA Enable Input	V _{ENABLE} and series resistor set I _{DDQ} . V _{ENABLE} < 0.2 volts disables device. On -die pull-down resistor will turn the part off if this node is allowed to float.
2	NC	No Connect or Ground	No internal connection to die
3	RF_In	RF input	Must provide external DC block to this node
4	RF_Out	RF output	Internally DC blocked. Do not apply DC voltage > 0.2 volts to this node
5	NC	No Connect or Ground	No internal connection to die
6	V_{DD}	Supply Voltage for the LNA	Distance of cap at M7 to pin 6 strongly influences the device match. Consult evaluation board Gerber files for an effective method of placing this cap that allows tuning flexibility. The value of this cap also affects the gain notch at 2.45 GHz.
PKG BASE	GND	Ground	Provides DC and RF ground for LNA, as well as thermal heat sink. Recommend multiple 8 mil vias beneath the package for optimal RF and thermal performance. Refer to evaluation board top layer graphic on schematic page.

V_{ENABLE} Truth Table:

V _{DD}	V _{ENABLE}	Mode
High	>=1.8 V	LNA On
High	<0.2 V	LNA Off



Released

GRF2101

High Gain, Ultra-LNA
Tuning Range: 4.0 to 10.0 GHz

Nominal Operating Parameters:

Parameter	Symbol	Specification			Unit	Condition
		Min.	Typ.	Max.		
High Gain Mode						$V_{DD} = 3.3\text{ V}; T_A = 25^\circ\text{ C}$
Test Frequency	F_{TEST}		5500		MHz	
Gain	S_{21}	16.0	17.5		dB	
Evaluation Board Noise Figure	NF		0.90	1.1	dB	
Output 1dB Compression	OP1dB	7.5	10.0		dBm	
Output Third Order Intercept	OIP3		22.0		dBm	-5.0 dBm P_{OUT} per tone at 2 MHz Spacing (5499 and 5501 MHz)
Switching Rise Time	T_{RISE}		500		ns	
Switching Fall Time	T_{FALL}		200		ns	
Supply Current (Quiescent)	I_{DD}		18.0		mA	
Enable Current	I_{ENABLE}		2.0		mA	
Disabled Mode						$V_{DD} = 3.3\text{ V}, V_{ENABLE} = 0.0\text{ V}$
Supply Current (Leakage)	I_{DD}		250		μA	
Thermal Data						
Thermal Resistance (Infra-Red Scan)	Θ_{jc}		100		$^\circ\text{C/W}$	
Channel Temperature @ +85 C reference (Package heat sink)	$T_{CHANNEL}$		91 (See note)		$^\circ\text{C}$	$V_{DD}: 3.3\text{ V}; I_{DDQ}: 18\text{ mA}; \text{No RF}$ $P_{DISS}: 60\text{ mW}$

Note: MTTF $>10^6$ hours for $T_{CHANNEL} \leq 170$ degrees C.



Released

GRF2101

High Gain, Ultra-LNA
Tuning Range: 4.0 to 10.0 GHz

GRF2101 Evaluation Board Data:

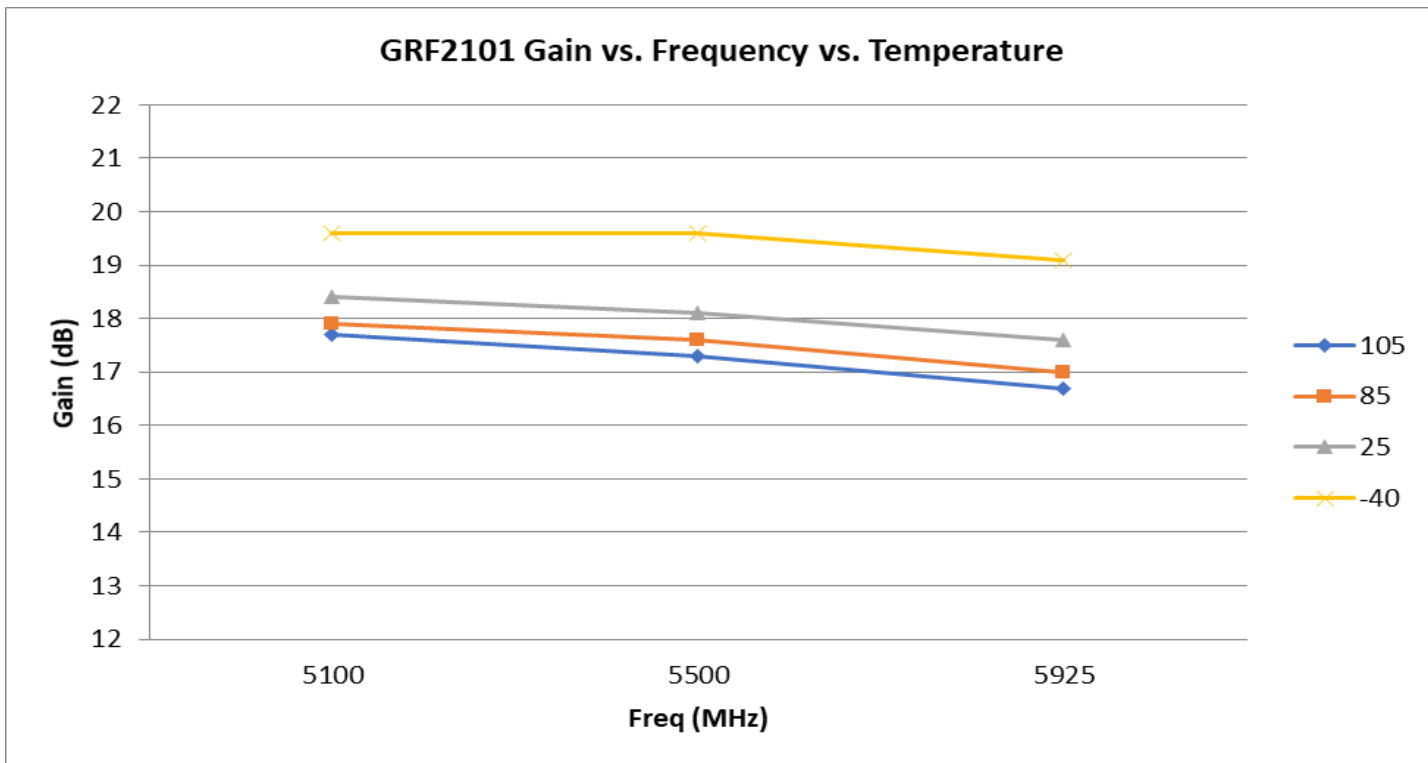
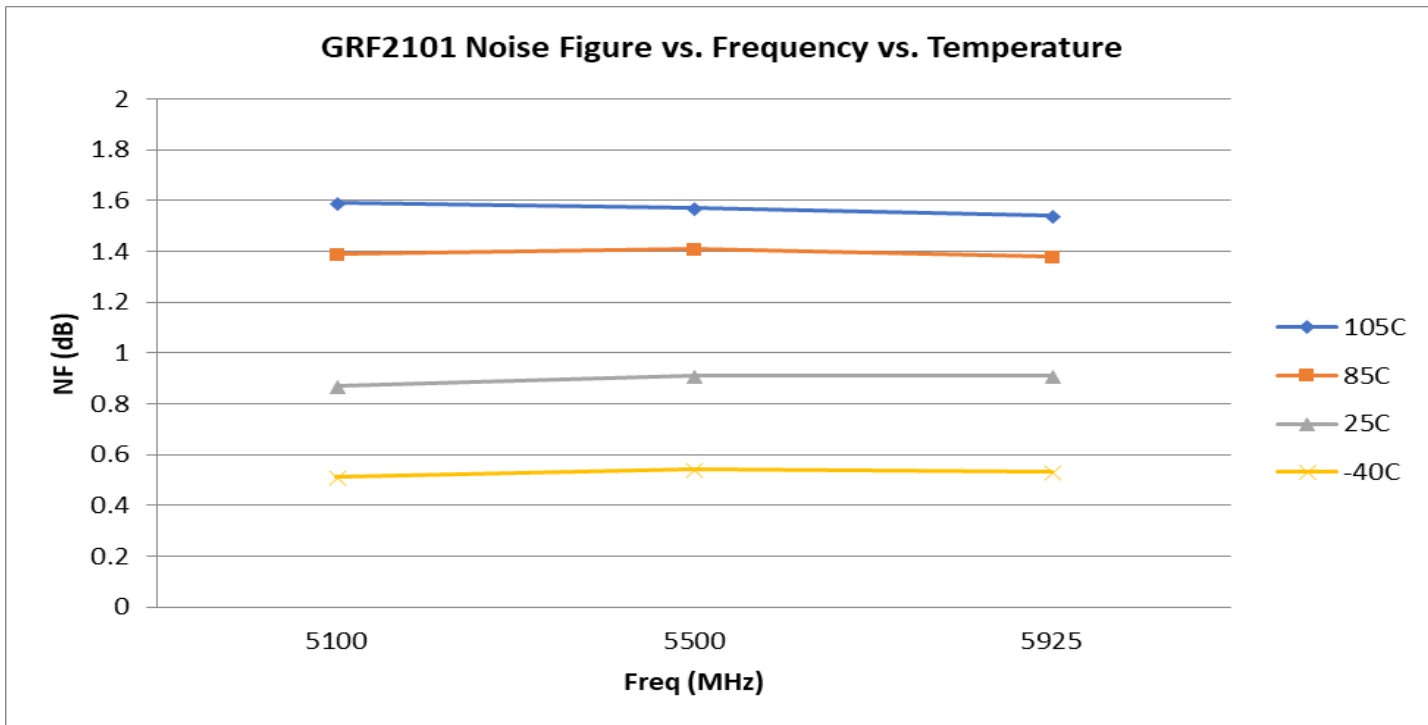

GRF2101 Evaluation Board Data:

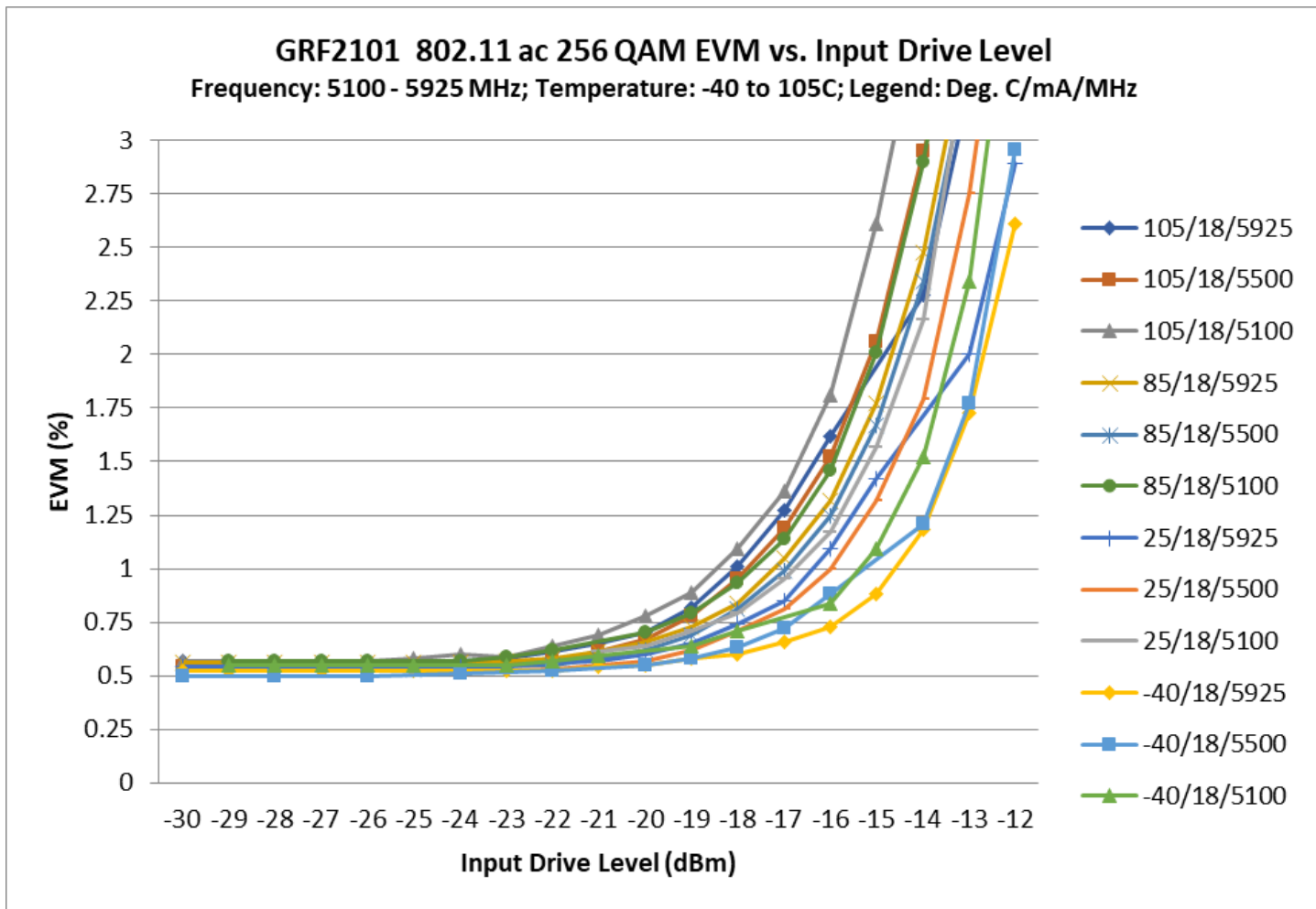



Released

GRF2101

High Gain, Ultra-LNA
Tuning Range: 4.0 to 10.0 GHz

GRF2101 Evaluation Board Data:

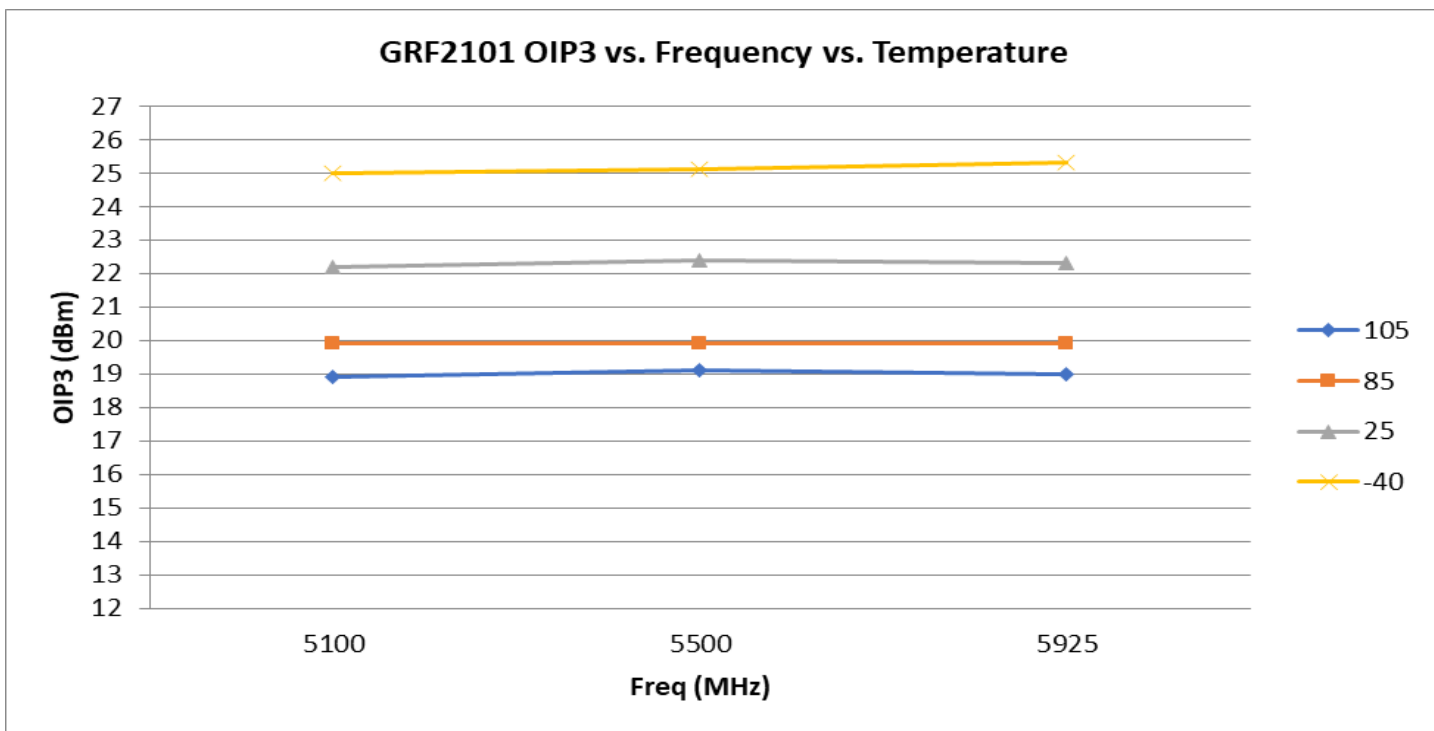
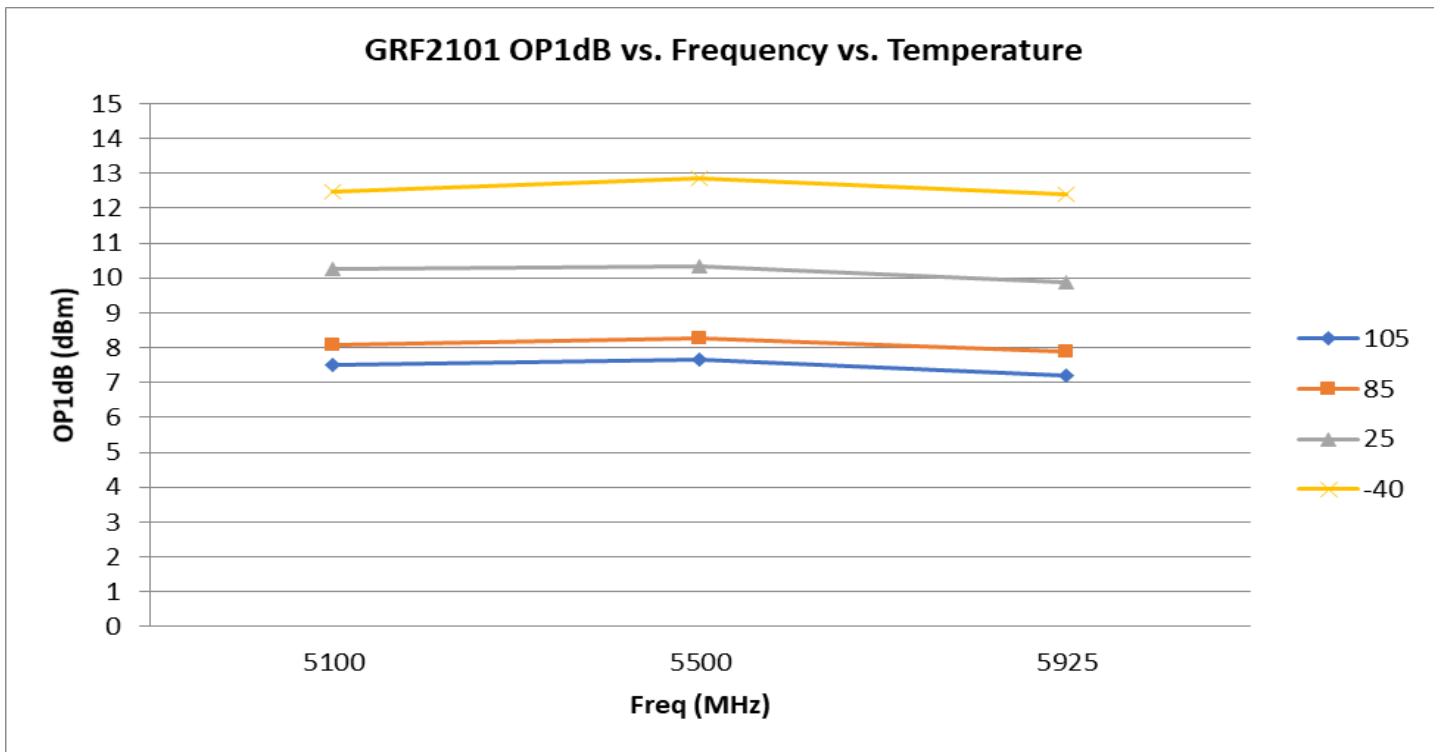



Released

GRF2101

High Gain, Ultra-LNA
Tuning Range: 4.0 to 10.0 GHz

GRF2101 Evaluation Board S-Params:

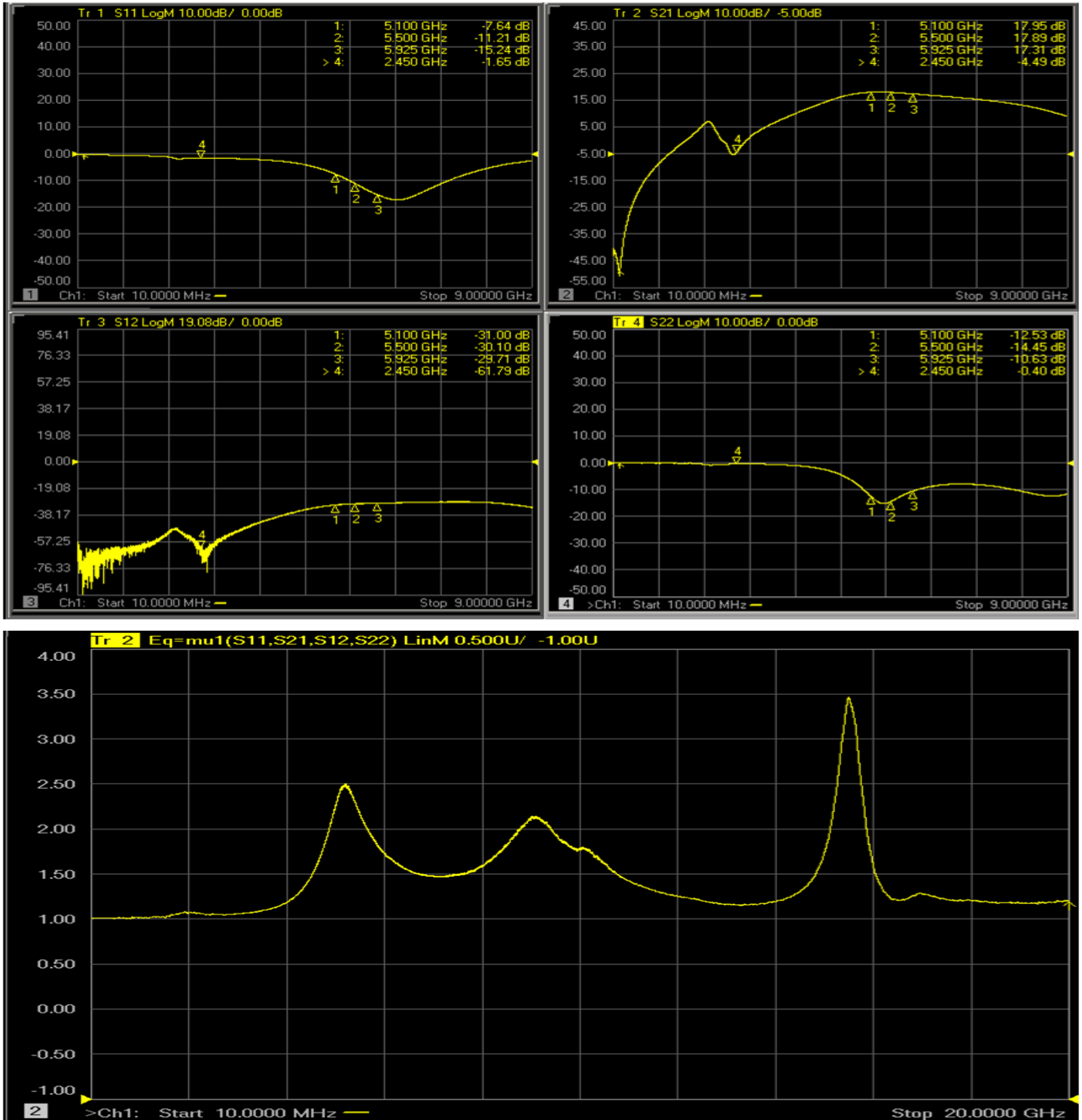

Note: $\mu \geq 1.0$ implies unconditional stability

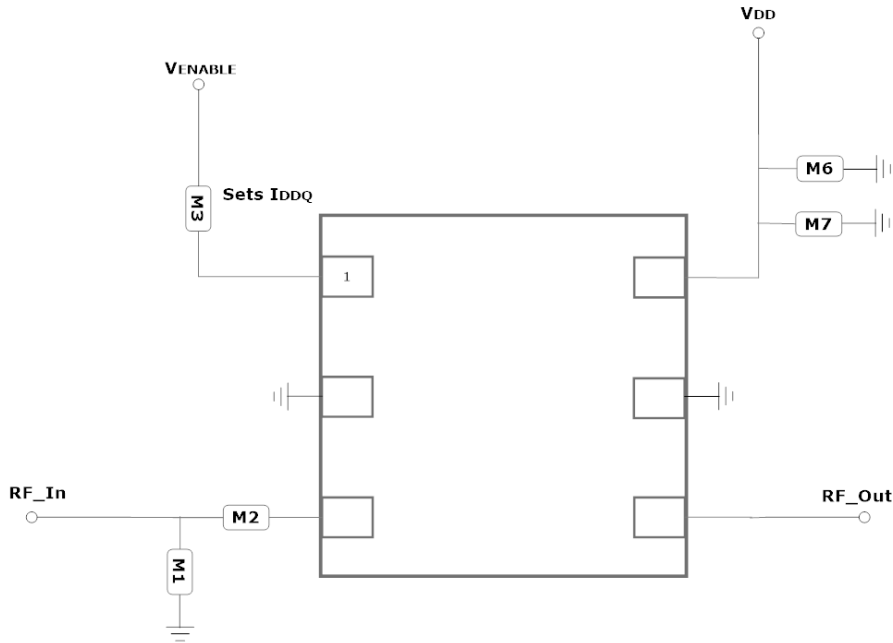

GRF2101 Application Schematic

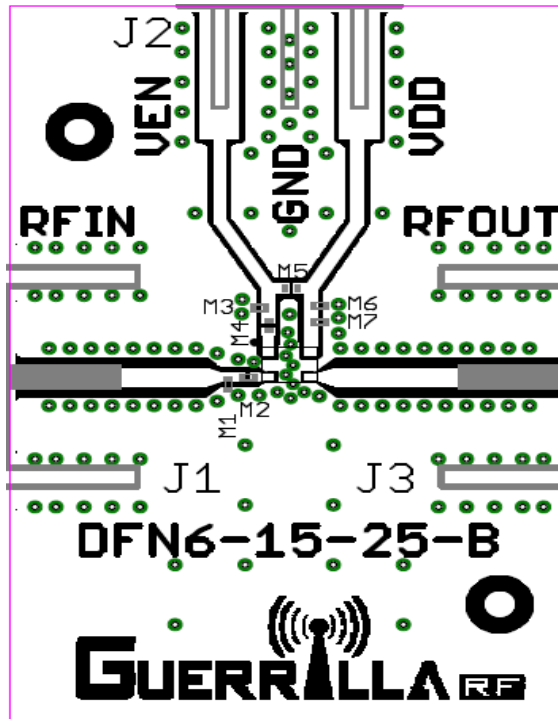

GRF2101 Evaluation Board Assembly Diagram



Released

GRF2101

High Gain, Ultra-LNA
Tuning Range: 4.0 to 10.0 GHz

GRF2101 Standard Evaluation Board BOM: (5.1 to 5.9 GHz Tune)

Component	Type	Manufacturer	Family	Value	Package Size	Substitution
M1	Capacitor	Murata	GJM	0.5 pF	0201	Ok (High Q)
M2	Capacitor	Murata	GJM	22 pF	0201	Ok (High Q)
M4 (see curves)	Resistor: 5%	Various	—	—	0201	ok
M6	Capacitor	Murata	GRM	0.1 uF	0201	ok
M7 (See note)	Capacitor	Murata	GJM	8.2 pF	0201	ok
Evaluation Board:	DFN6-15-25-B					

Note: Distance of M7 from pin 6 is critical for in-band matching. The value of M7 influences the location of the gain notch around 2.4 GHz. Recommend that customer application boards allow for some flexibility in the placement of M7 to optimize tuning the device.

Iddq vs. Bias Resistor:

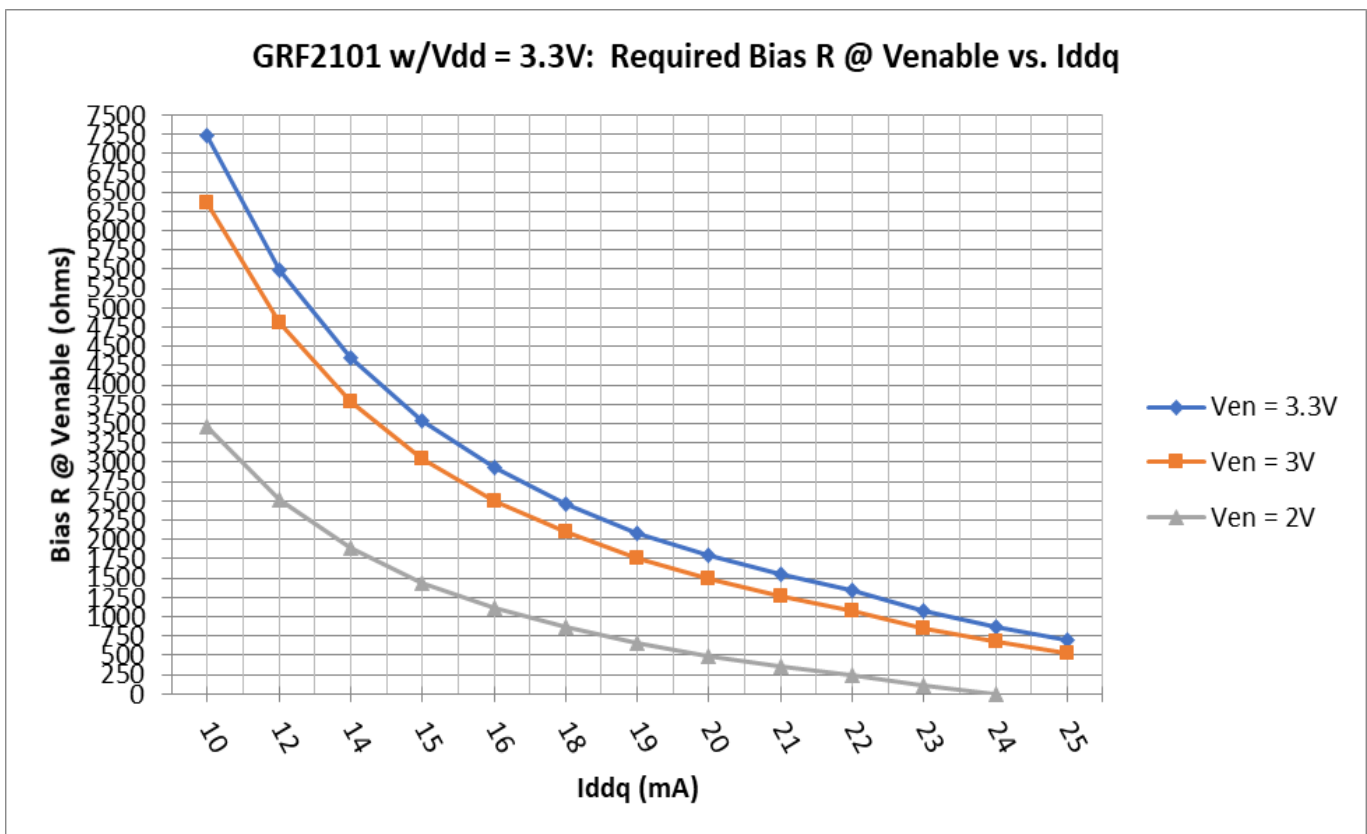

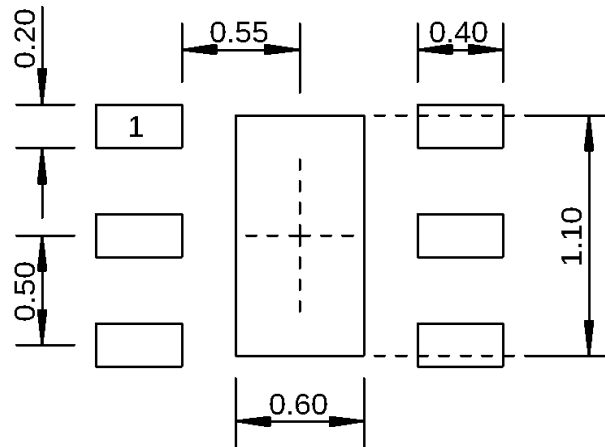

Dimensions in millimeters

1.5 mm DFN-6 Suggested PCB Footprint (Top View)

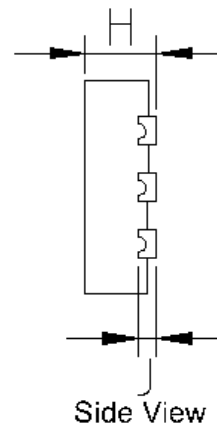
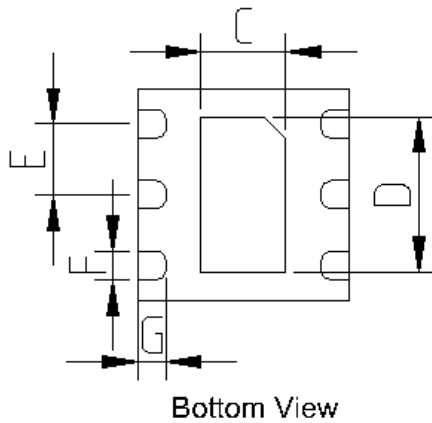
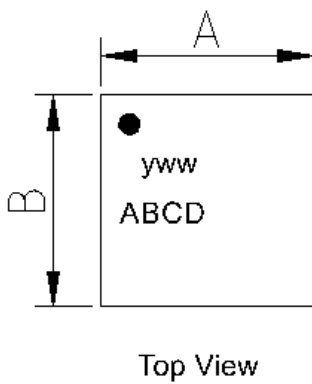

Dimensions (MM)	
A	1.5 +/- 0.050
B	1.5 +/- 0.050
C	.6 +/- 0.050
D	1.1 +/- 0.050
E	.5 Bsc
F	.2 +/- 0.050
G	.2 +/- 0.050
H	.45 +/- 0.050
J	.12 Ref.

1.5 mm DFN-6 Package Dimensions

Tape and Reel Information:

Guerrilla RF's Tape and Reel specification complies with the Electronics Industries Association (EIA) standards for 'Embossed Carrier Tape of Surface Mount Components for Automatic Handling'. Reference EIA-481. See the table on the following page for Tape and Reel specifications along with units per reel.

Devices are loaded with pins down into the carrier pocket with protective cover tape, wound into a plastic reel. Each reel will be packaged in a cardboard box. There will be product labels on the reel, the protective ESD bag and the outside surface of the box.

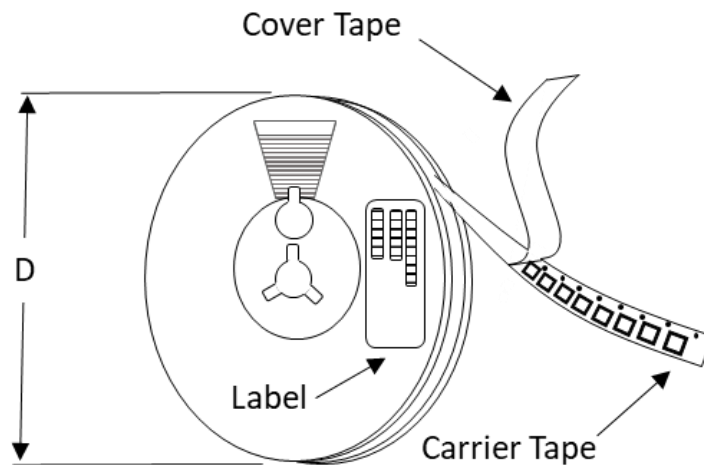

Tape and Reel Packaging with Reel Diameter Noted (D)

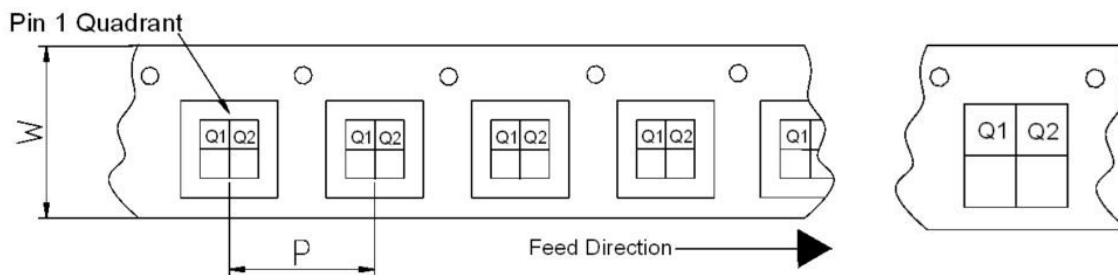

Carrier Tape Width (W), Pitch (P), Feed Direction and Pin 1 Quadrant Information



Released

GRF2101

High Gain, Ultra-LNA
Tuning Range: 4.0 to 10.0 GHz

Tape and Reel Specification and Device Package Information Table

Package				Carrier Tape			Reel	
Type	Dimensions (mm)	Leads	Weight (mg)	Width (W) (mm)	Pocket Pitch (P) (mm)	Pin 1 Quadrant	Diameter (D) (inches)	Units per Reel
QFN	2.0 x 2.0 x 0.50	12	7	8	4	Q1	7	2500
QFN	3.0 x 3.0 x 0.85	16	24	12	8	Q1	7	1500
DFN	1.5 x 1.5 x 0.45	6	4	8	4	Q1	7	2500
DFN	2.0 x 2.0 x 0.75	8	12	8	4	Q1	7	2500
LFM	3.5 x 3.5 x 0.75	See	TBD	12	8	Q2	7	1500
LFM	4.0 x 4.0 x 0.75	See note	TBD	12	8	Q2	7	1500

Note: Lead count may vary. Reference applicable product data sheet