



## Product Description

GRF2105 is a broadband, ultra-low noise linear amplifier designed for small cell, wireless infrastructure and other high performance RF applications. The standard tune exhibits outstanding NF and linearity, return losses and enhanced gain flatness over 0.4 to 3.8 GHz.

The device is operated from a supply voltage (Vdd) range of 2.7 to 6.0 V with a typical bias condition of 5 volts and 70 mA for optimal efficiency and linearity.

Consult with the GRF applications engineering team for custom tuning/evaluation board data and device s-parameters.

## Features

Reference: 5V/70mA/2.5 GHz

- Gain: 20.5 dB
- Eval Board NF: 0.77 dB
- OP1dB: 21.0 dBm
- OIP3: 37.0 dBm
- Flexible bias voltage and Current
- Process: GaAs pHEMT

## Applications

- Broadband LNA
- Linear Driver Amplifier
- Small Cells and Cellular Repeaters
- Wireless Backhaul
- C-Band Amplifier to 5.0 GHz
- 3.5 GHz CBRS
- TDD-LTE

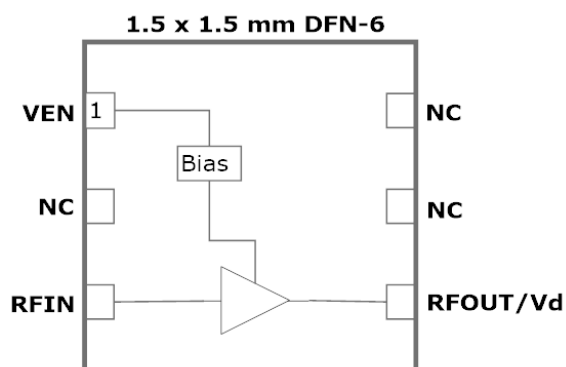

## Absolute Ratings:

Parameter	Symbol	Min.	Max.	Unit
Supply Voltage	V <sub>DD</sub>	0	6.0	V
RF Input Power: (Load VSWR < 2:1; V <sub>D</sub> : 5.0 volts)	P <sub>IN MAX</sub>		20	dBm
Operating Temperature (Package Heat Sink)	T <sub>AMB</sub>	-40	105	°C
Maximum Channel Temperature (MTTF > 10 <sup>6</sup> Hours)	T <sub>MAX</sub>		170	°C
Maximum Dissipated Power	P <sub>DISS MAX</sub>		0.6	W
<b>Electrostatic Discharge:</b>				
Charged Device Model:	CDM	1500		V
Human Body Model:	HBM	250		V
<b>Storage:</b>				
Storage Temperature	T <sub>STG</sub>	-65	150	°C
Moisture Sensitivity Level	MSL		1	--



**Caution!** ESD Sensitive Device



Exceeding Absolute Maximum Rating conditions may cause permanent damage to the device.

**Note:** For manufacturing information, see the [Guerrilla-RF.com](http://Guerrilla-RF.com) website for the following document located on the GRF2105 landing page: Manufacturing Note—MN-001 Product Tape and Reel, Solderability and Package Outline Specification:

[Link to manufacturing note:](#)

### Pin Out (Top View)

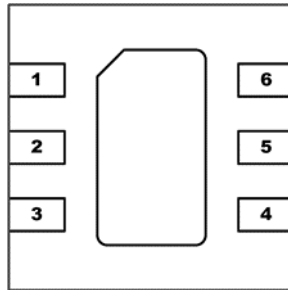

### Pin Assignments:

Pin	Name	Description	Note
1	V <sub>ENABLE</sub>	Enable Voltage Input	V <sub>ENABLE</sub> and series resistor set I <sub>DDQ</sub> . V <sub>ENABLE</sub> < =0.2 volts disables device. On -die pull-down resistor will turn the part off if this node is allowed to float.
2	NC	No Connect or Ground	No internal connection to die
3	RF_In	LNA RF input	Internally matched 50Ω. An external DC blocking cap must be used.
4	RF_Out	LNA RF output	Internally matched 50Ω. V <sub>DD</sub> must be applied through a choke to this pin
5	NC	No Connect or Ground	No internal connection to die
6	NC	No Connect or Ground	No internal connection to die
PKG BASE	GND	Ground	Provides DC and RF ground for LNA, as well as thermal heat sink. Recommend multiple 8 mil vias beneath the package for optimal RF and thermal performance. Refer to evaluation board top layer graphic on schematic page.



Released

# GRF2105

Enhanced Gain Flatness LNA  
0.4 to 5.0 GHz

## Nominal Operating Parameters:

Parameter	Symbol	Specification			Unit	Condition
		Min.	Typ.	Max.		
Test Frequency	$F_{TEST}$		2.5		GHz	$V_{DD} = 5.0\text{ V}$ , $T_A = 25^\circ\text{C}$
Gain	S21	19.0	20.5		dB	
Evaluation Board Noise Figure	NF		0.77		dB	
Output 1dB Compression Power	OP1dB	19.0	21.0		dBm	
Output 3rd Order Intercept	OIP3		37.0		dBm	2.0 dBm $P_{OUT}$ per tone (2499 and 2501 MHz)
Switching Rise Time	$T_{RISE}$		1200		ns	
Switching Fall Time	$T_{FALL}$		400		ns	
Supply Current	$I_{DD}$		70		mA	
Enable Current	$I_{ENABLE}$		1.5		mA	
<b>Disabled Mode</b>						
Leakage Current	$I_{LEAKAGE}$		270		$\mu\text{A}$	$V_{DD}: 5.0\text{V}$ ; $V_{ENABLE}: 0.0\text{V}$
<b>Thermal Data</b>						
Thermal Resistance: (Infra-Red Scan)	$\theta_{jc}$		55		$^\circ\text{C/W}$	On standard Evaluation Board
Channel Temperature @ +85 C Reference (Package heat sink)	$T_{CHANNEL}$		104 (See note)		$^\circ\text{C}$	$V_{DD}: 5.0\text{ V}$ ; $I_{DDQ}: 70\text{ mA}$ ; No RF; $P_{DISS}: 350\text{ mW}$

Note: MTTF >10<sup>6</sup> hours for  $T_{CHANNEL} < =170$  degrees C.

GRF2105 Evaluation Board Measured Data: (0.4 to 3.8 GHz Tune)

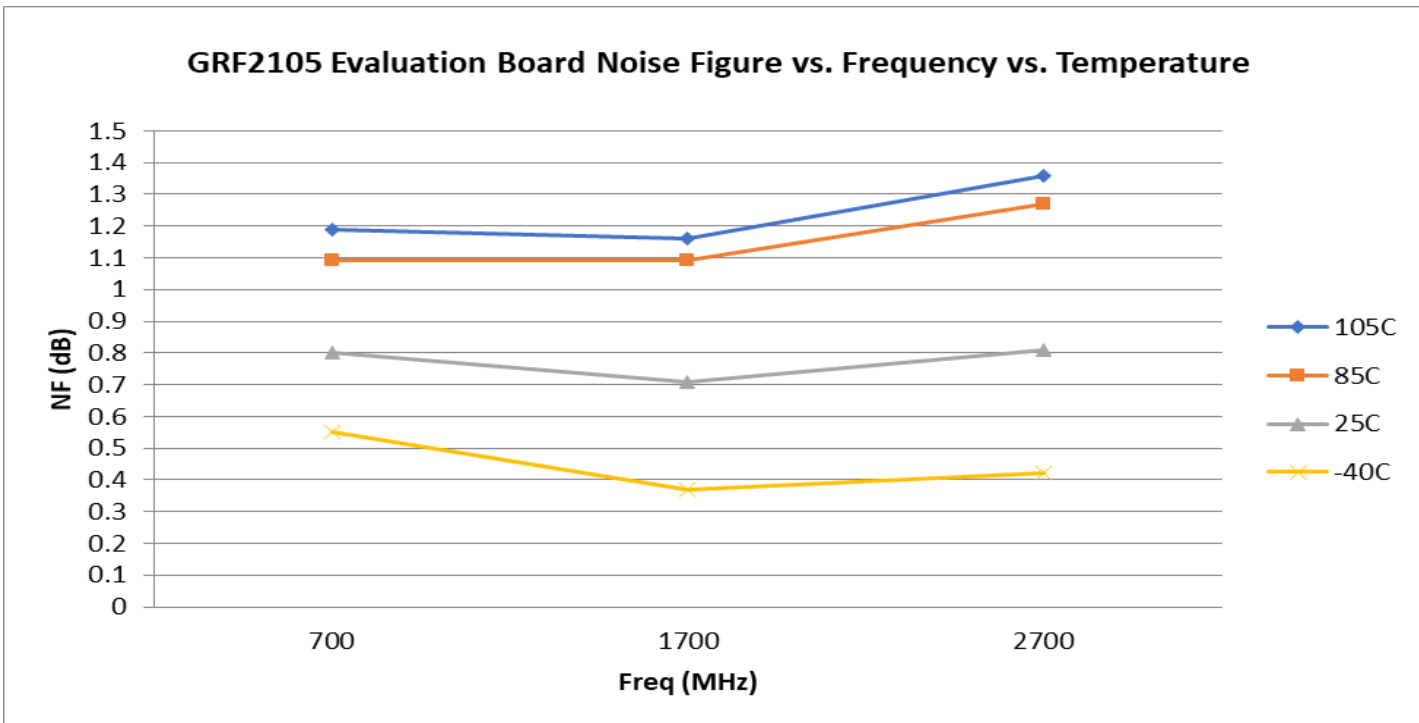
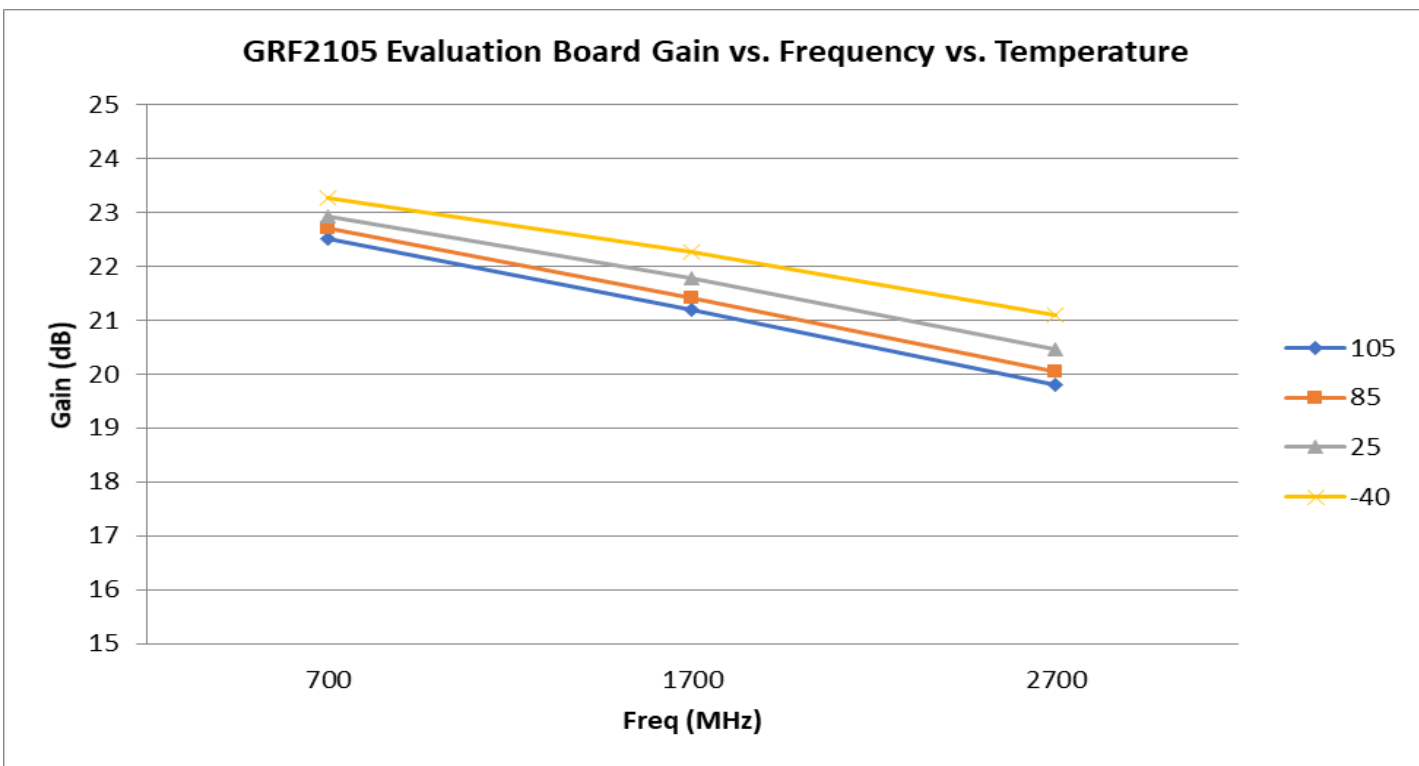

GRF2105 Evaluation Board Data: (0.4 to 3.8 GHz Tune)

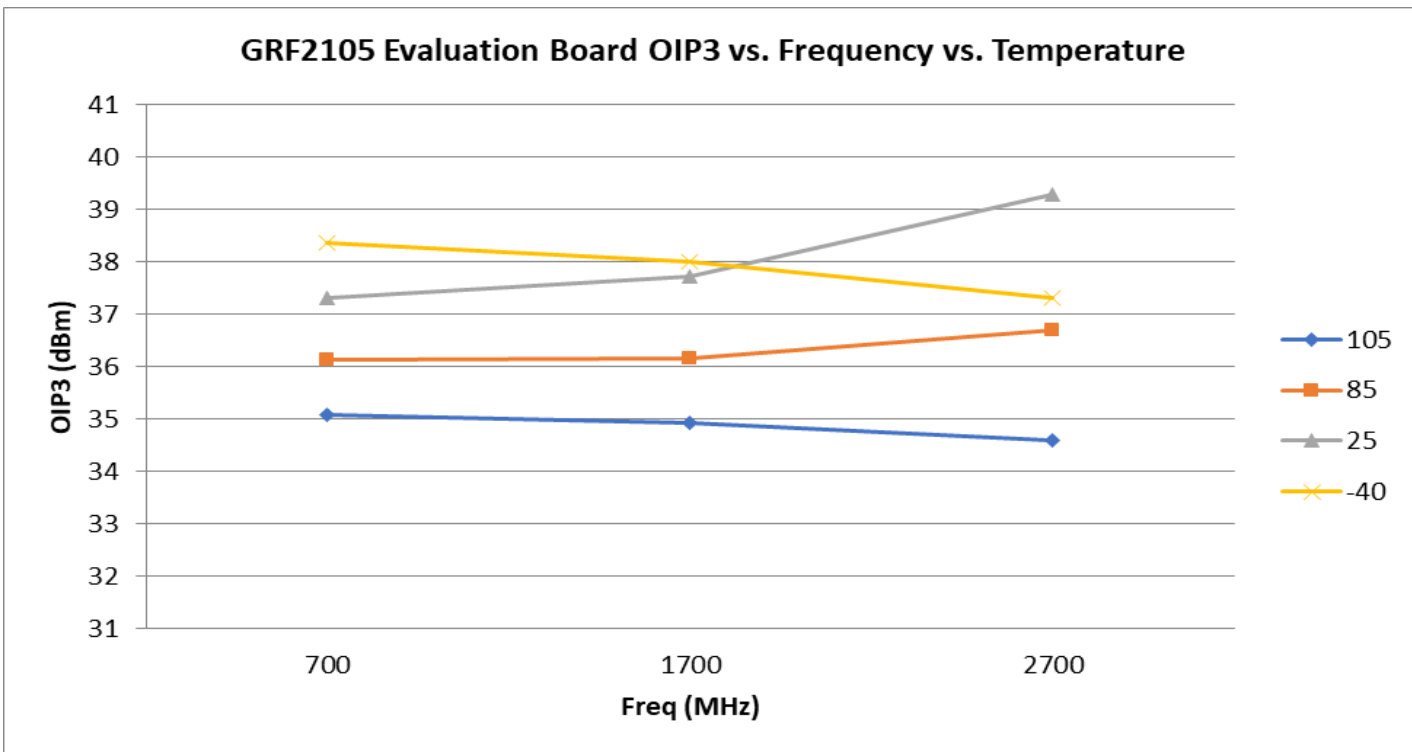
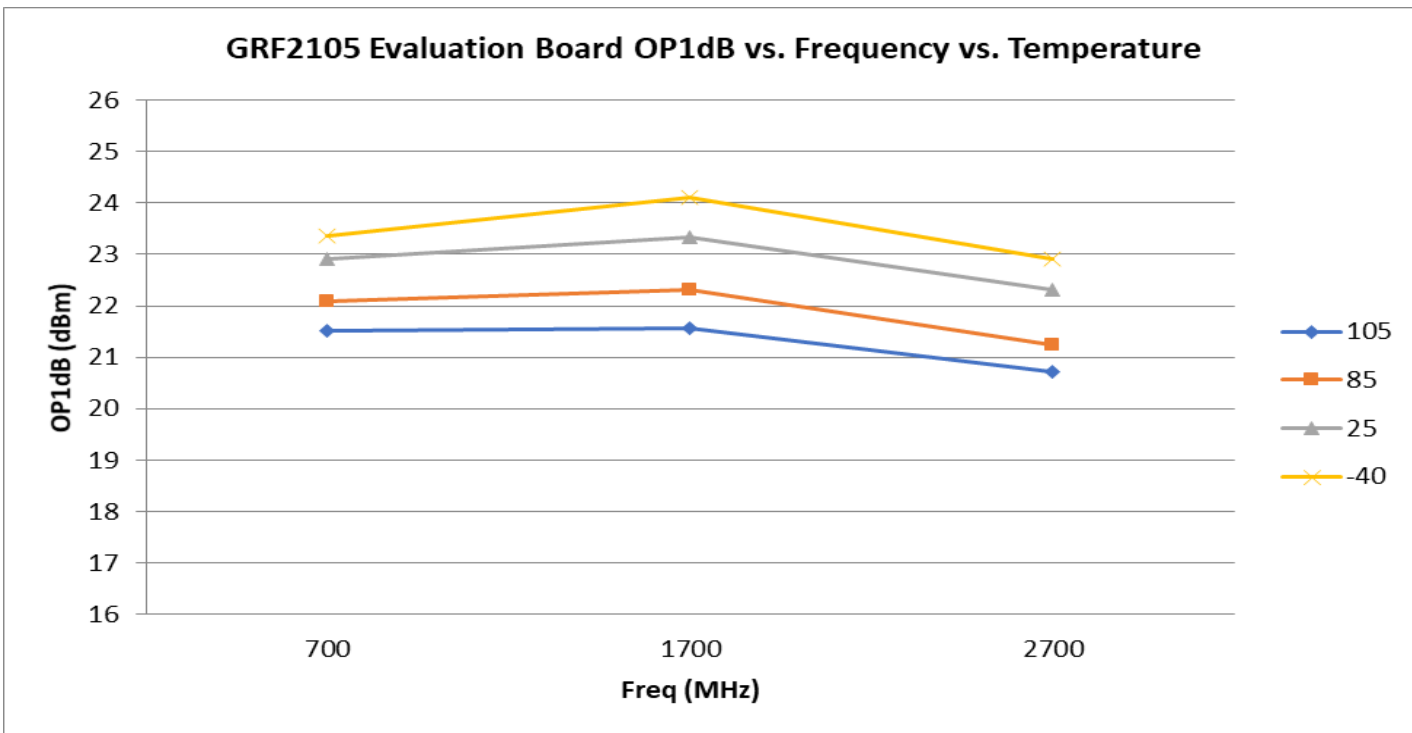

GRF2105 Evaluation Board Data: (0.4 to 3.8 GHz Tune)

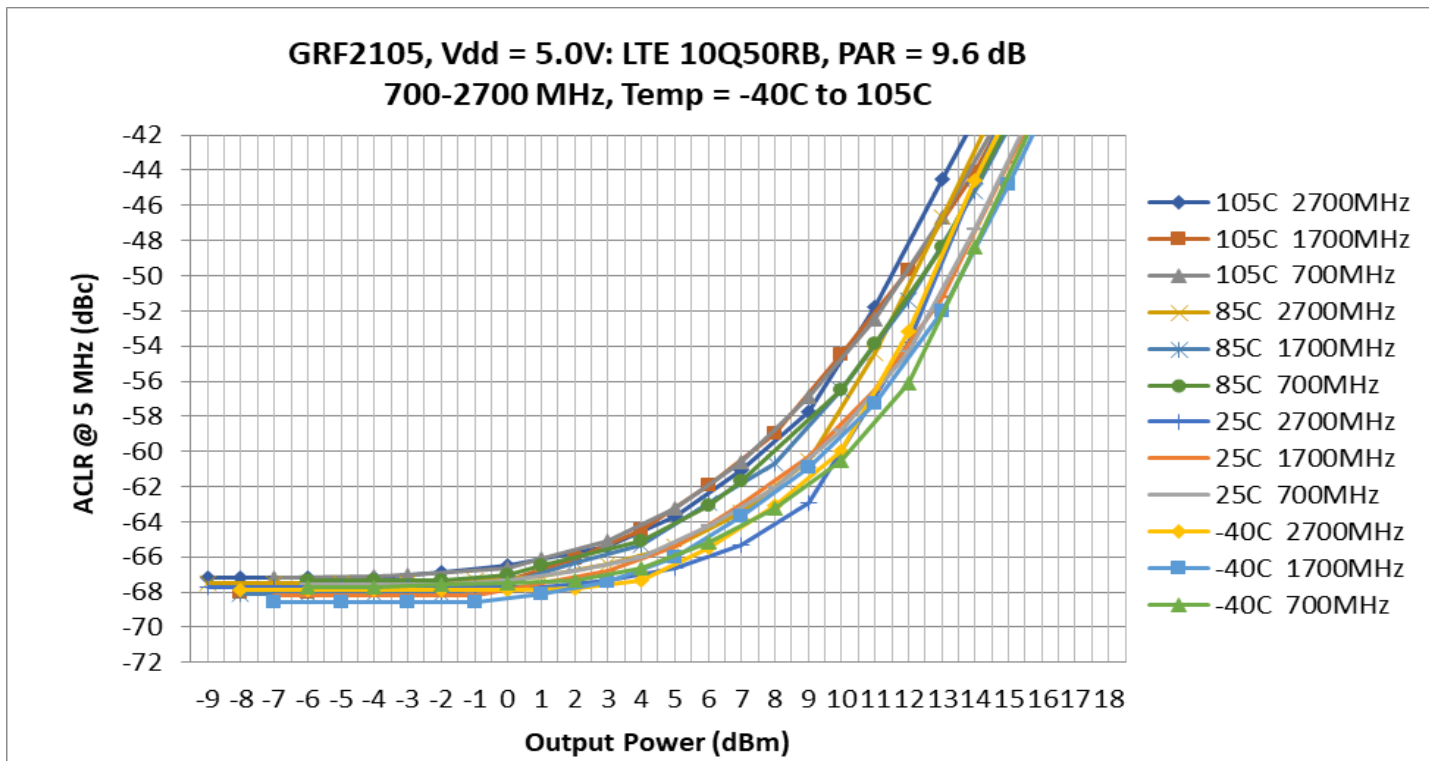



Released

# GRF2105

Enhanced Gain Flatness LNA  
0.4 to 5.0 GHz

## GRF2105 Evaluation Board S-Pars and Stability Mu Factor: (0.4 to 3.8 GHz Tune)

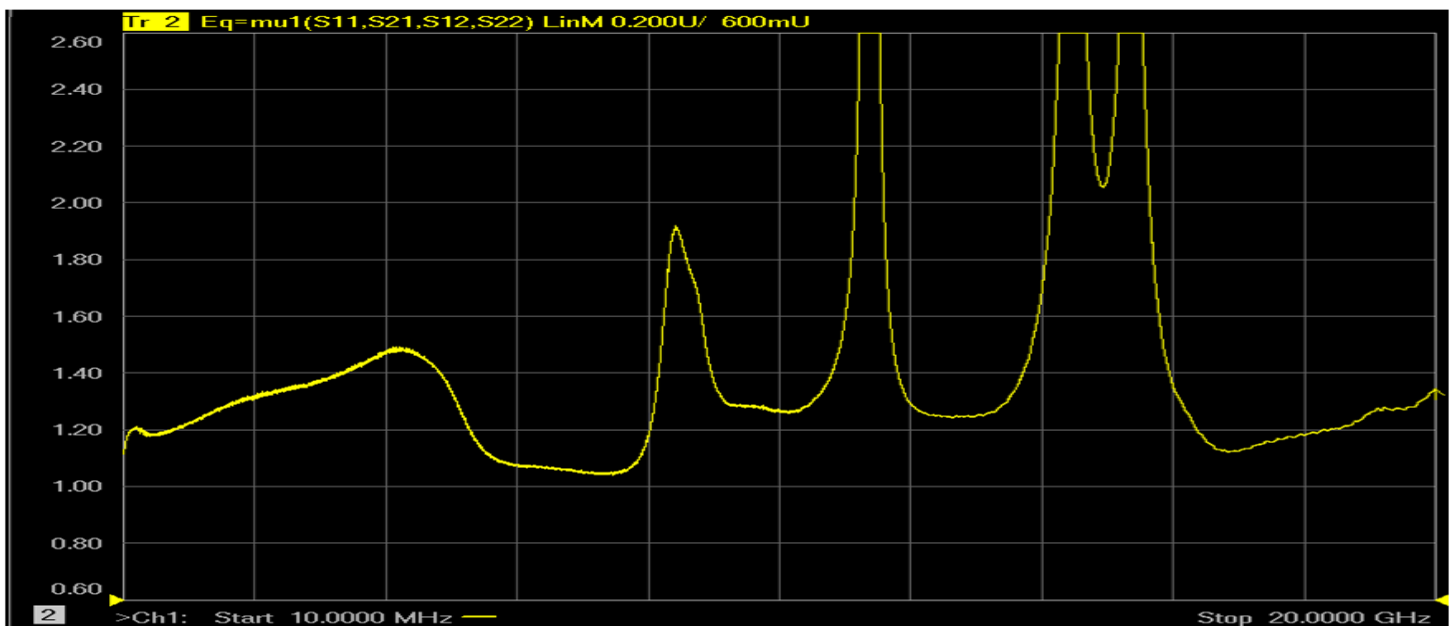
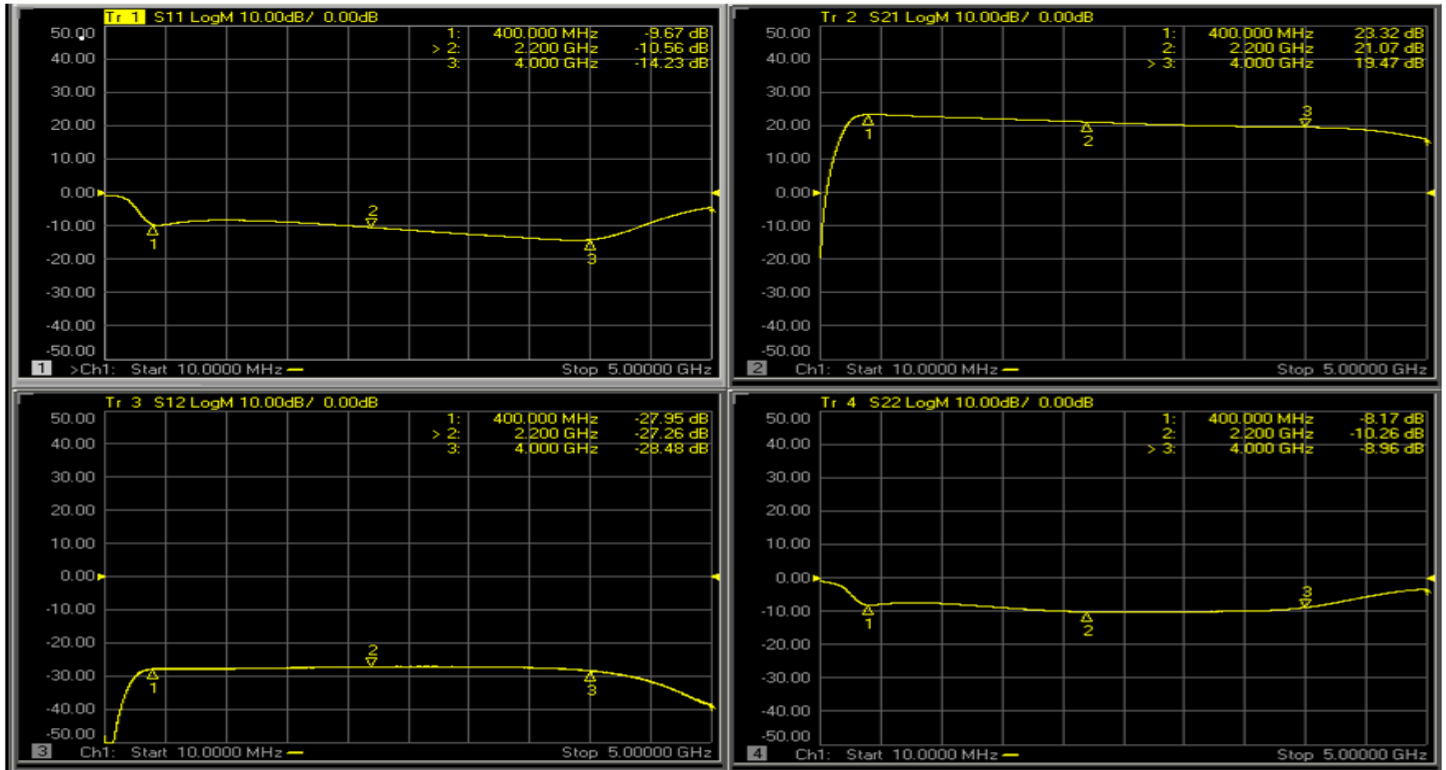

Note: Mu factor  $\geq 1.0$  implies unconditional stability.



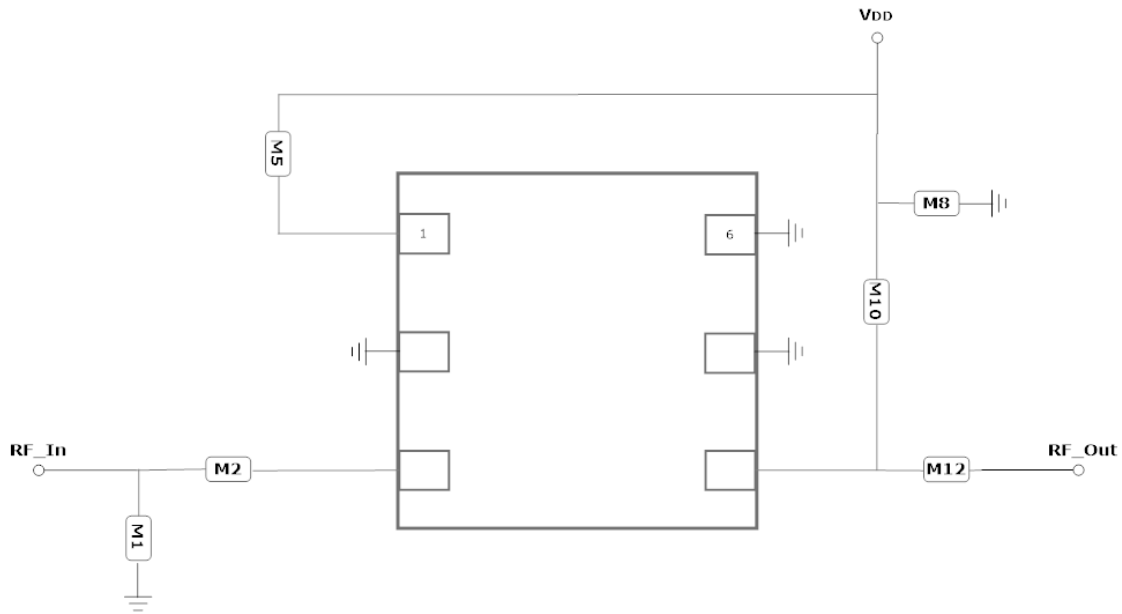

GRF2105 Application Schematic

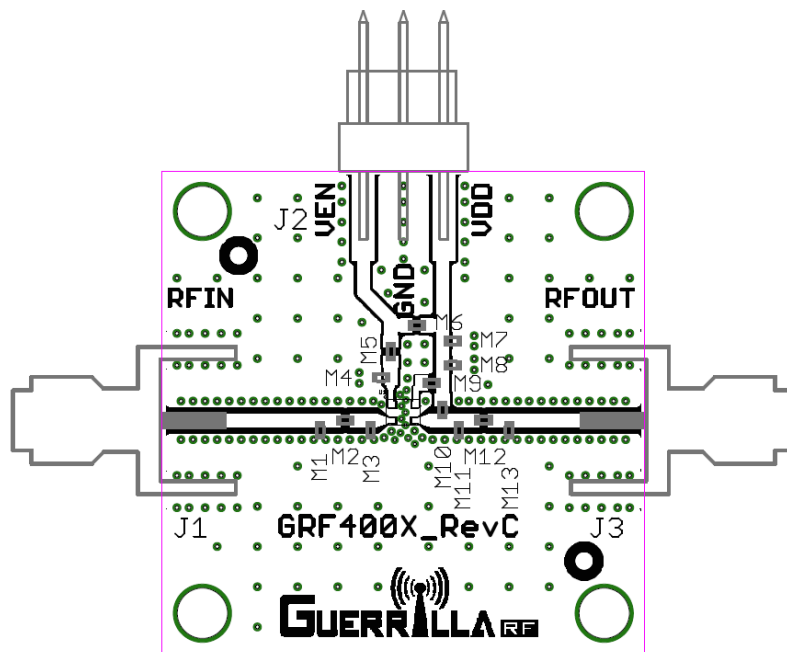

GRF2105 Evaluation Board Assembly Diagram



Released

# GRF2105

Enhanced Gain Flatness LNA  
0.4 to 5.0 GHz

## GRF2105 Standard Evaluation Board BOM: (0.4 to 3.8 GHz Tune)

Component	Type	Manufacturer	Family	Value	Package Size	Substitution
M1	Inductor	Murata	LQW/LQP	27 nH	0402	ok
M2	Capacitor	Murata	GJM	15 pF	0402	ok
M5	Resistor	Various	5%	Sets Iddq	0402	ok
M8	Capacitor	Murata	GRM	0.1 uF	0402	ok
M10	Inductor	Murata	LQW/LQP	27 nH	0402	ok
M12	Capacitor	Murata	GRM	1000pF	0402	ok

## GRF2105 Bias R vs. Iddq:

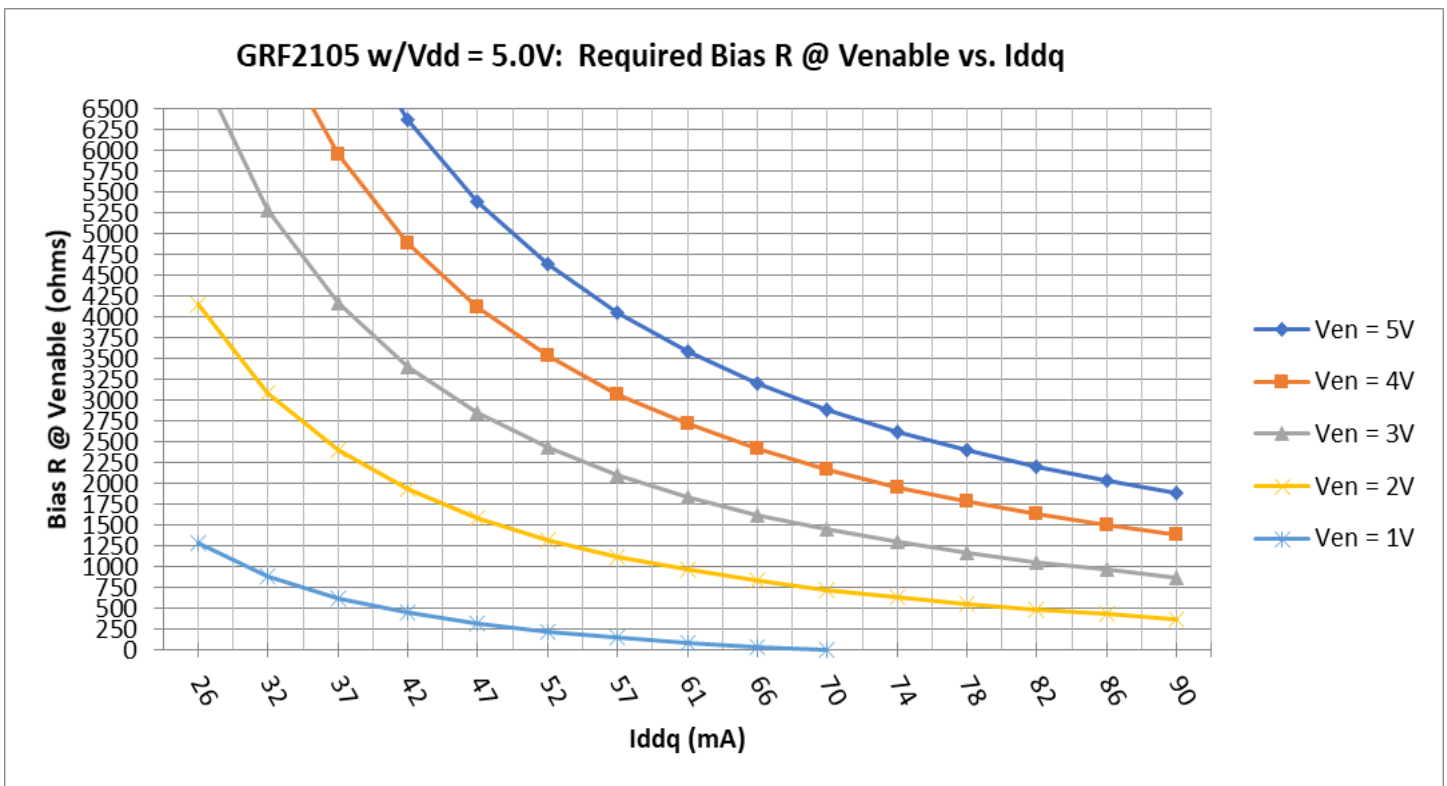

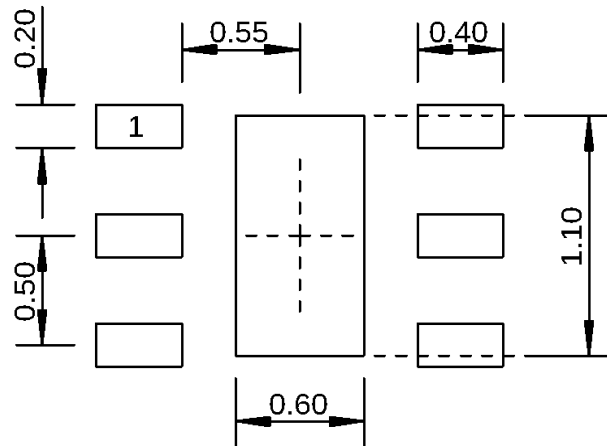

Dimensions in millimeters

### 1.5 mm DFN-6 Suggested PCB Footprint (Top View)

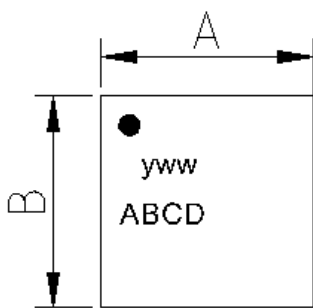

Top View

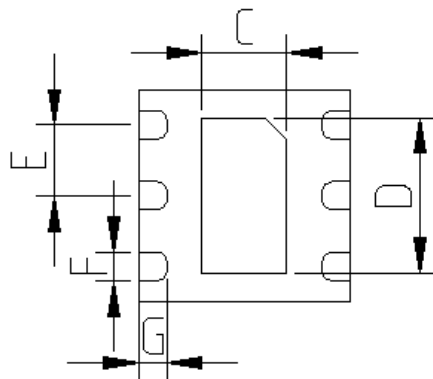

Bottom View

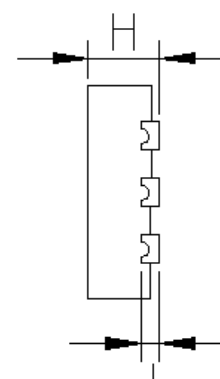

Side View

Dimensions (MM)	
A	1.5 +/- 0.050
B	1.5 +/- 0.050
C	.6 +/- 0.050
D	1.1 +/- 0.050
E	.5 Bsc
F	.2 +/- 0.050
G	.2 +/- 0.050
H	.45 +/- 0.050
J	.12 Ref.

### 1.5 mm DFN-6 Package Dimensions

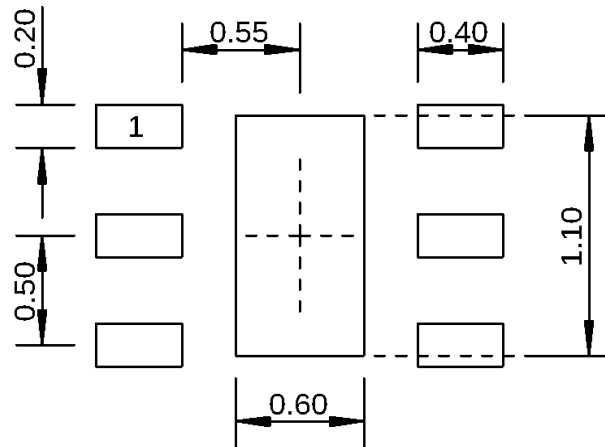

Dimensions in millimeters

### 1.5 mm DFN-6 Suggested PCB Footprint (Top View)

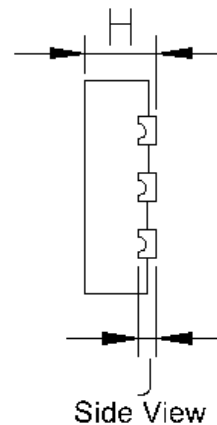
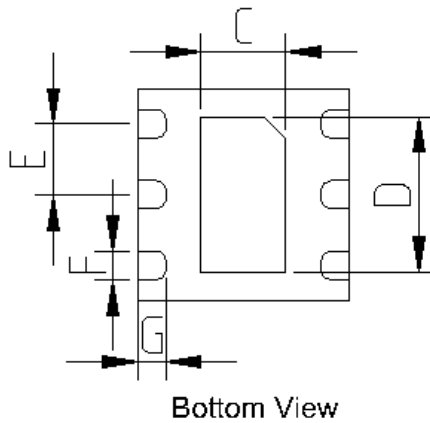
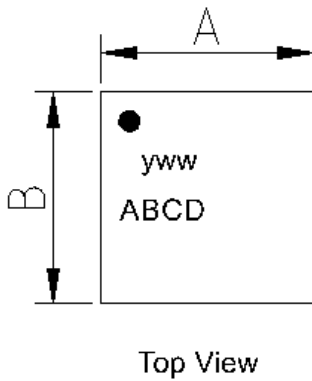

Dimensions (MM)	
A	1.5 +/- 0.050
B	1.5 +/- 0.050
C	.6 +/- 0.050
D	1.1 +/- 0.050
E	.5 Bsc
F	.2 +/- 0.050
G	.2 +/- 0.050
H	.45 +/- 0.050
J	.12 Ref.

### 1.5 mm DFN-6 Package Dimensions