



## Product Description

GRF2541 is an ultra-low noise amplifier (LNA) with bypass designed for IEEE 802.11a/n/ac/p applications in the 5GHz band (5.1 GHz to 5.925 GHz). The device exhibits outstanding de-embedded noise figure (NF) of 1.0 dB along with a high gain of approximately 16.4 dB

Guerrilla Armor™ technology provides exceptional off-state isolation in the presence of high RF input signal levels in LNA disabled mode. The LNA is operated from a single positive supply of 2.7 to 5.0 V with typical bias condition of 3.3 volts and 18 mA.

Consult with the GRF applications engineering team for custom tuning/evaluation board data and device s-parameters.

## Features

Reference: 3.3V/18mA/5.5 GHz

- EVB NF: 1.2 dB
- Gain: 16.4 dB
- IP1dB: -10.2 dBm
- Flexible Bias Voltage and Current
- Internally Matched to 50 Ω
- Process: GaAs pHEMT

## Applications

- WiFi Access Points
- Mobile WiFi Devices
- 802.11p Vehicle Communications
- Microwave Backhaul

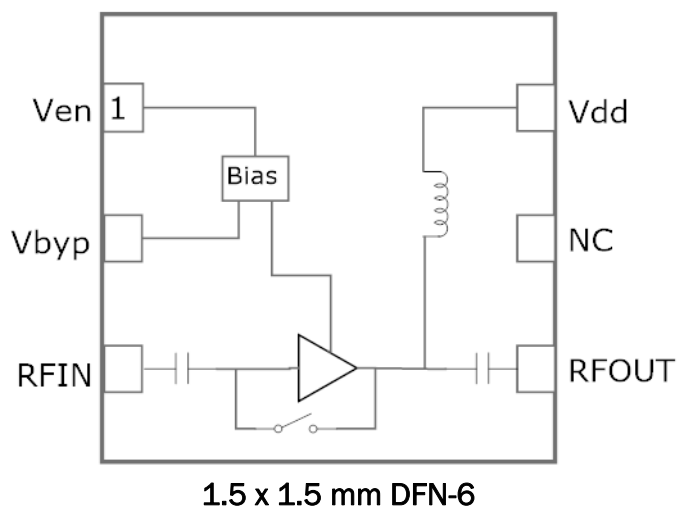



## Absolute Ratings:

Parameter	Symbol	Min.	Max.	Unit
Supply Voltage	V <sub>DD</sub>	0	6.0	V
RF Input Power: (Load VSWR < 2:1; V <sub>D</sub> : 5.0 volts)	P <sub>IN MAX</sub>		15	dBm
Operating Temperature (Package Heat Sink)	T <sub>AMB</sub>	-40	105	°C
Maximum Channel Temperature (MTTF > 10 <sup>6</sup> Hours)	T <sub>MAX</sub>		170	°C
Maximum Dissipated Power	P <sub>DISS MAX</sub>		200	mW
<b>Electrostatic Discharge:</b>				
Charged Device Model:	CDM	1500		V
Human Body Model:	HBM	250		V
<b>Storage:</b>				
Storage Temperature	T <sub>STG</sub>	-65	150	°C
Moisture Sensitivity Level	MSL		1	--



**Caution!** ESD Sensitive Device



Exceeding Absolute Maximum Rating conditions may cause permanent damage to the device.

**Note:** For manufacturing information, see the [Guerrilla-RF.com](http://Guerrilla-RF.com) website for the following document located on the GRF2541 landing page: **Manufacturing Note—MN-001 Product Tape and Reel, Solderability and Package Outline Specification.**

[Link to manufacturing note](#)

## Pin Out (Top View)



## Pin Assignments:

Pin	Name	Description	Note
1	V <sub>EN</sub>	LNA enable	V <sub>EN</sub> and series resistor set I <sub>DD0</sub> . V <sub>EN</sub> < 0.2 volts disables device. On-die pull-down resistor will turn the part off if this node is allowed to float.
2	V <sub>BYP</sub>	Bypass function enable	Logic high invokes the LNA bypass mode.
3	RF_In	LNA RF input	Internally matched to 50 Ω. These ports may be DC connected to ground externally but no DC > 0.2 volts should be applied to these ports.
4	RF_Out	LNA RF output	
5	NC	No Connect or Ground	No internal connections to die
6	VDD	Supply Voltage for the LNA	Requires bypass capacitance as close as possible to pin on PCB
PKG BASE	GND	Ground	Provides DC and RF ground for LNA, as well as thermal heat sink. Recommend multiple 8 mil vias beneath the package for optimal RF and thermal performance. Refer to evaluation board top layer graphic on schematic page.

## V<sub>ENABLE</sub> Truth Table:

Mode	Description	V <sub>ENABLE</sub>	V <sub>BYP</sub>
High Gain	High LNA Gain	1	0
Bypass	High Linearity Bypass	0	1
Disabled	LNA Powered Down	0	0
Logic Level "0"	Logic Low	0.0V to 0.1V	0.0V to 0.2V
Logic Level "1"	Logic High	1.5V to V <sub>dd</sub>	1.5V to V <sub>dd</sub>



Preliminary

# GRF2541

High Gain, Ultra-LNA w/Bypass  
802.11ac: 4.9–6.0 GHz

## Nominal Operating Parameters:

Parameter	Symbol	Specification			Unit	Condition
		Min.	Typ.	Max.		
<b>High Gain Mode</b>						$V_{DD} = 3.3\text{ V}; V_{EN}: \text{High}; V_{BYP}: 0.0\text{ V}$
Test Frequency	$F_{TEST}$		5.5		GHz	
Gain	$S_{21}$		16.4		dB	
Noise Figure (Evaluation Board)	NF		1.2		dB	
Input Power for 1.0% EVM (Gain Mode)	$IP_{1\%}$		-22.0		dBm	Waveform: 802.11a/g; PAR: 11.6 dB
Input Power for 1.0% EVM (Bypass Mode)	$IP_{1\%}$		-9.0		dBm	Waveform: 802.11a/g; PAR: 11.6 dB
Input 1dB Compression Point	$IP_{1dB}$		-10.2		dBm	
Supply Current	$I_{DD}$		18		mA	
Enable Current (Logic high)	$I_{EN}$		700		uA	
Enable Current (Logic low)	$I_{EN}$		0.0		mA	Pin 1 will pull itself to logic low if allowed to float
<b>Bypass Mode</b>						$V_{DD}: 3.3\text{ V}; V_{EN}: 0.0\text{ V}; V_{BYP}: \text{High}$
Gain	$S(2,1)$		-5.1		dB	
Input 1dB Compression Point	$IP_{1dB}$		5.0		dBm	
Bypass Current (Logic high)	$I_{BYP}$		150		uA	
Bypass Current (Logic low)	$I_{BYP}$		0.0		mA	Pin 2 will pull itself to logic low if allowed to float
Supply Current (Leakage)	$I_{DD}$		600		uA	
<b>Disabled Mode (Guerrilla Armor)</b>						$V_{DD} = 3.3\text{V}, V_{EN}=V_{BYP}= 0.0\text{ V}$
Gain	$S(2,1)$		-32		dB	RF Input Power: +20 dBm
Supply Current (Leakage)	$I_{DD}$		600		uA	
<b>Thermal Data</b>						
Thermal Resistance (Infra-Red Scan)	$\Theta_{jc}$		150		°C/W	
Channel Temperature @ +85 C reference (Package heat sink)	$T_{CHANNEL}$		94 (See note)		°C	$V_{DD}: 3.3\text{ V}; I_{DDQ}: 18\text{ mA}; \text{No RF}; \text{Dissipated Power}: 60\text{ mW}$

Note: MTF >10<sup>6</sup> hours for  $T_{CHANNEL} \leq 170$  degrees C.



Preliminary

# GRF2541

High Gain, Ultra-LNA w/Bypass  
802.11ac: 4.9–6.0 GHz

## GRF2541 Evaluation Board Measured Data:

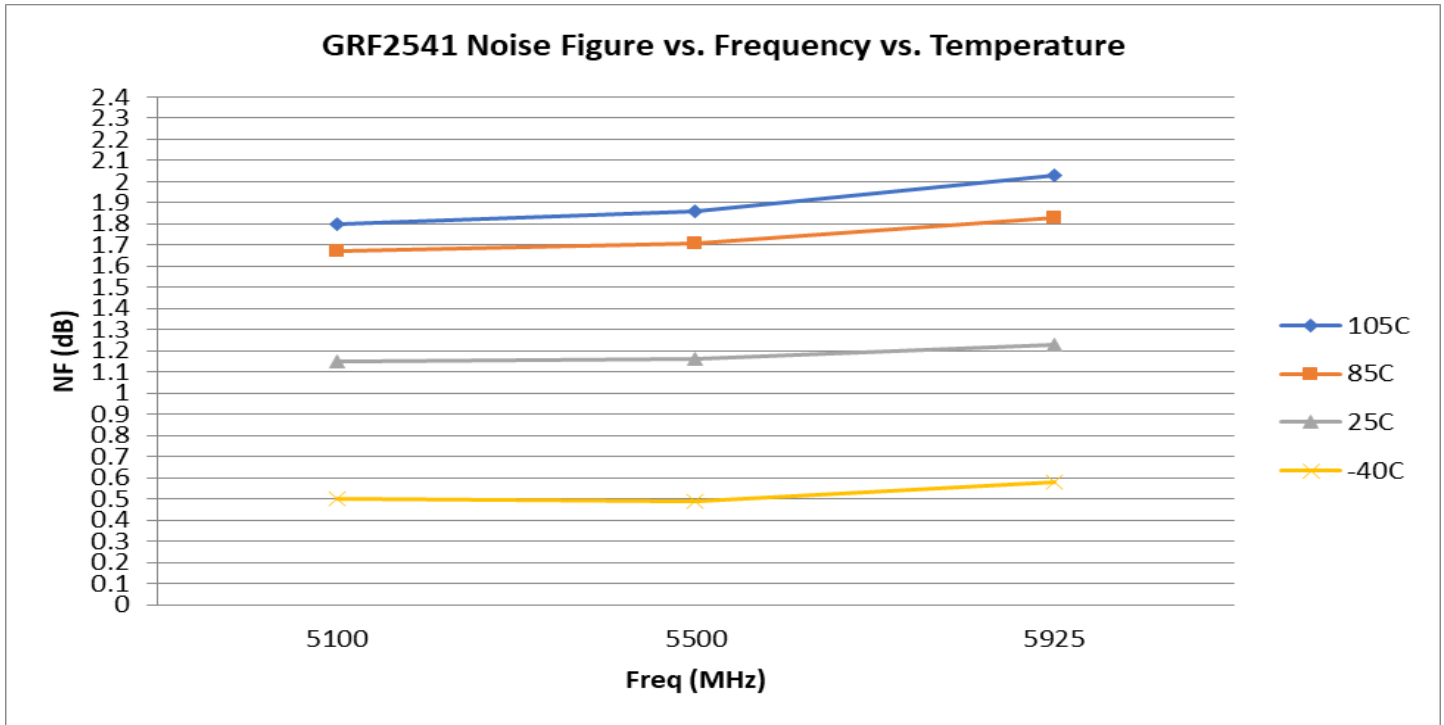



Preliminary

# GRF2541

High Gain, Ultra-LNA w/By-pass  
802.11ac: 4.9–6.0 GHz

## GRF2541 Evaluation Board Measured Data:

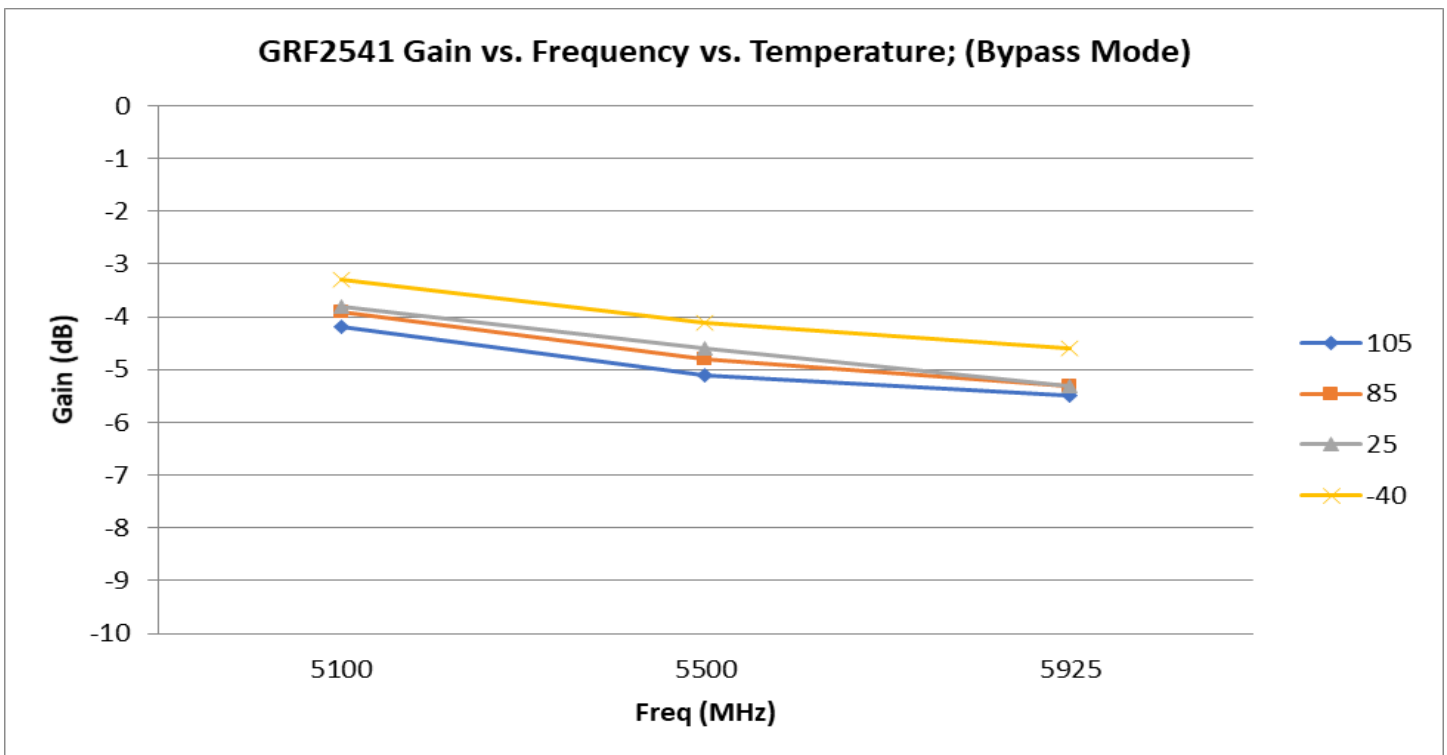
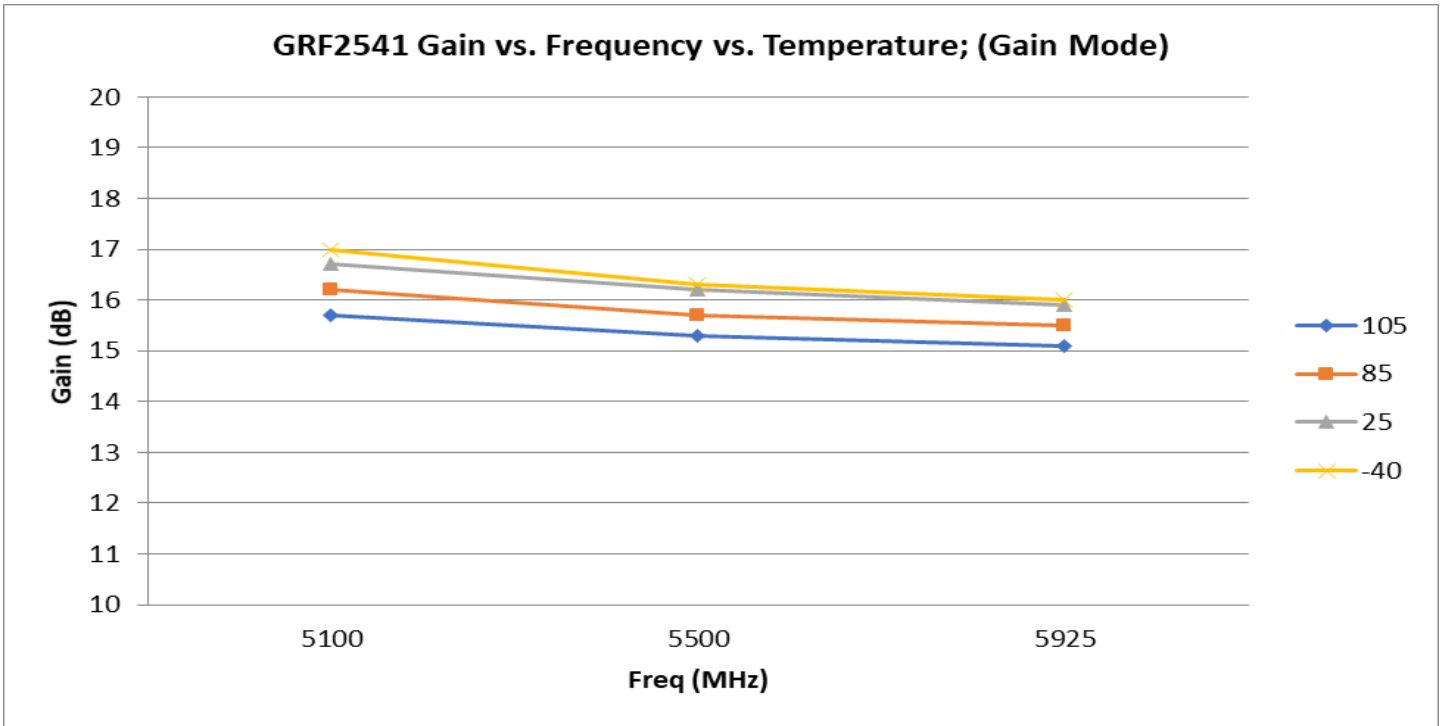



Preliminary

# GRF2541

High Gain, Ultra-LNA w/Bypass  
802.11ac: 4.9–6.0 GHz

## GRF2541 Evaluation Board Data:

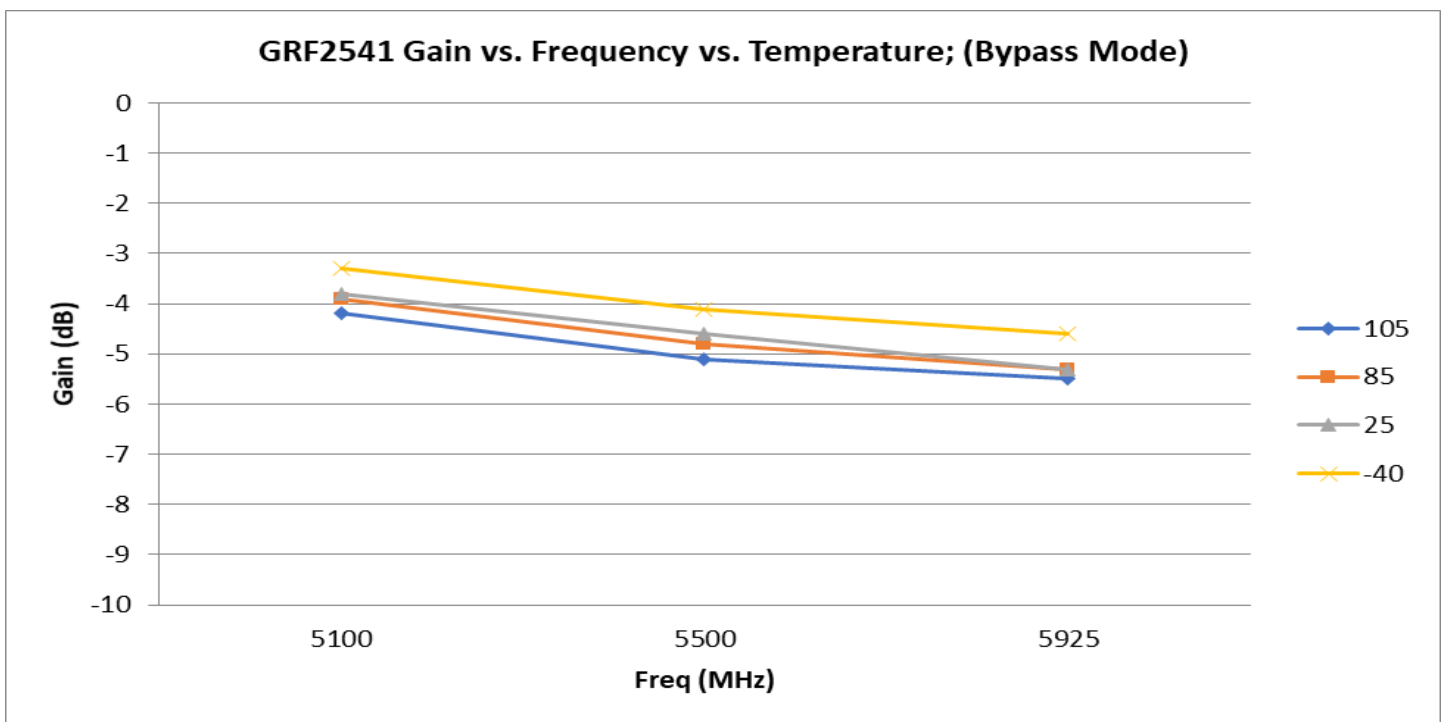
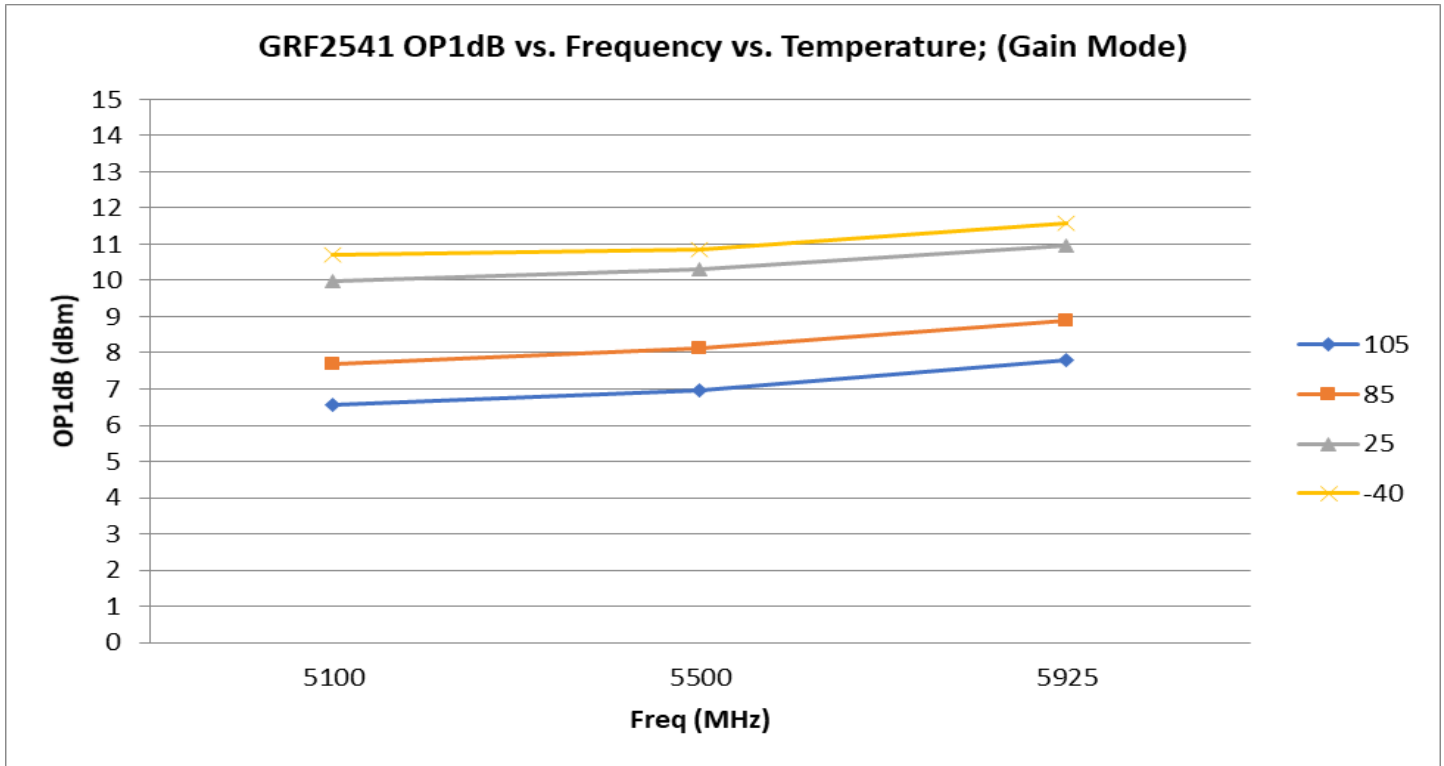



Preliminary

# GRF2541

High Gain, Ultra-LNA w/Bypass  
802.11ac: 4.9–6.0 GHz

## GRF2541 Evaluation Board Data:

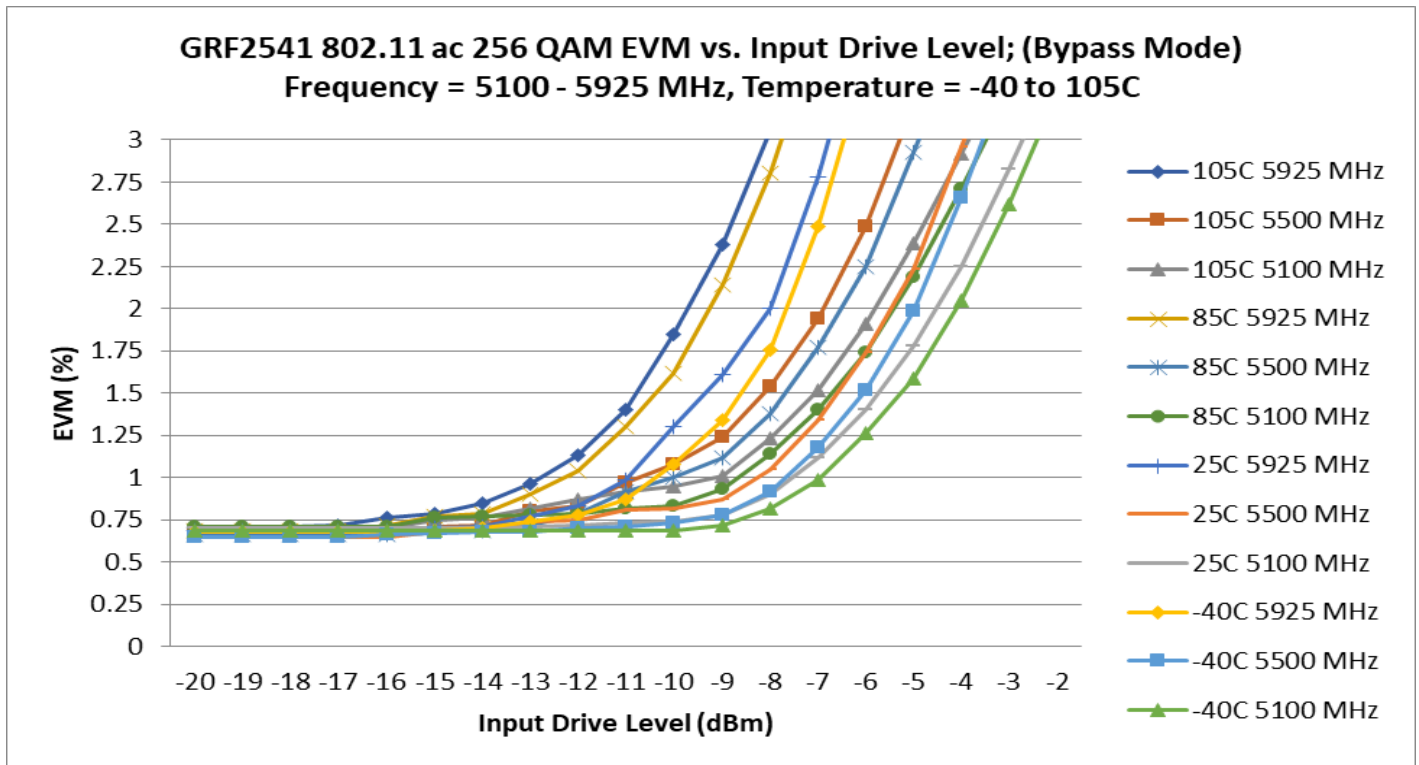
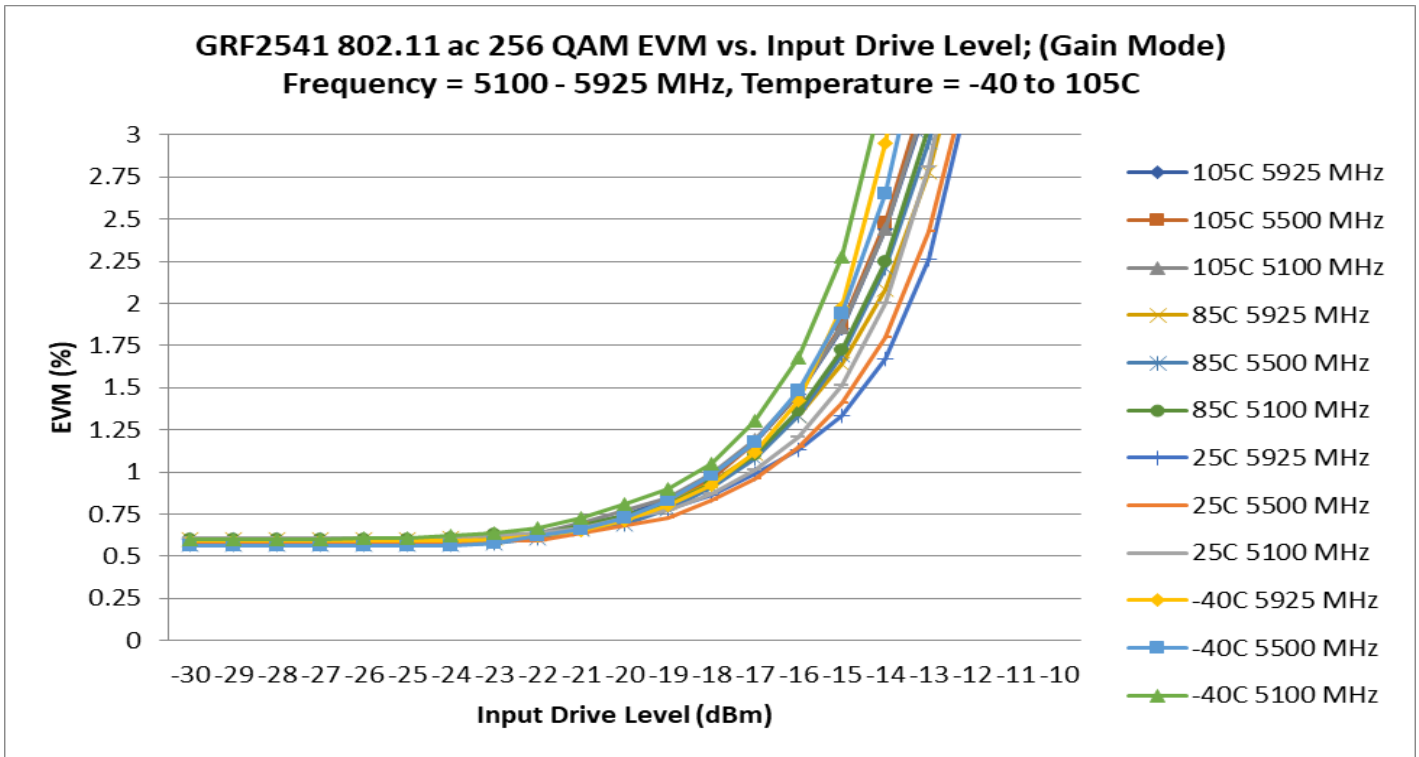





Preliminary

# GRF2541

High Gain, Ultra-LNA w/Bypass  
802.11ac: 4.9–6.0 GHz

## GRF2541 Evaluation Board S-Pars (Gain and Bypass Modes):

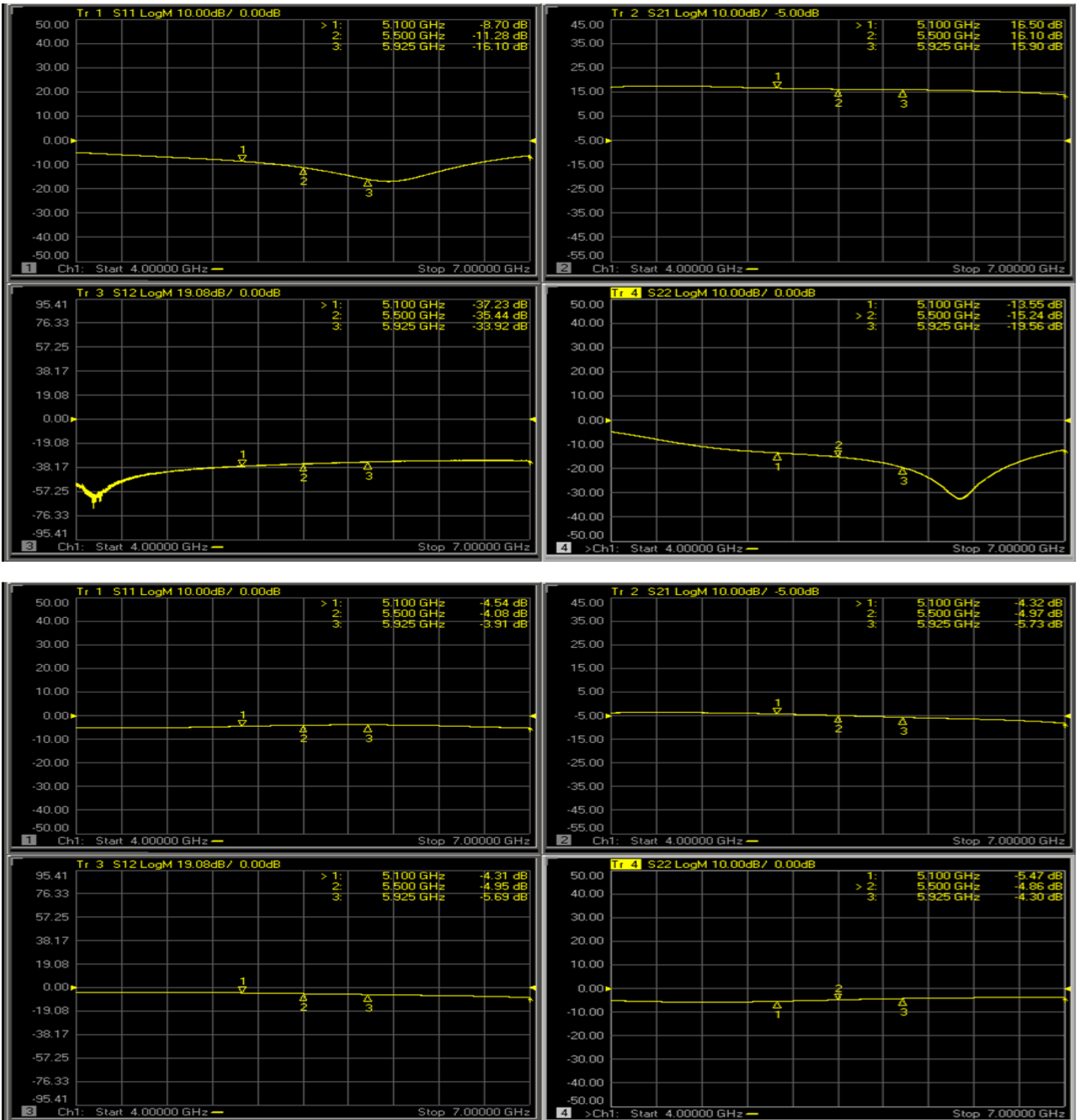



Preliminary

# GRF2541

High Gain, Ultra-LNA w/Bypass  
802.11ac: 4.9–6.0 GHz

## GRF2541 Evaluation Board Stability Mu Factor:

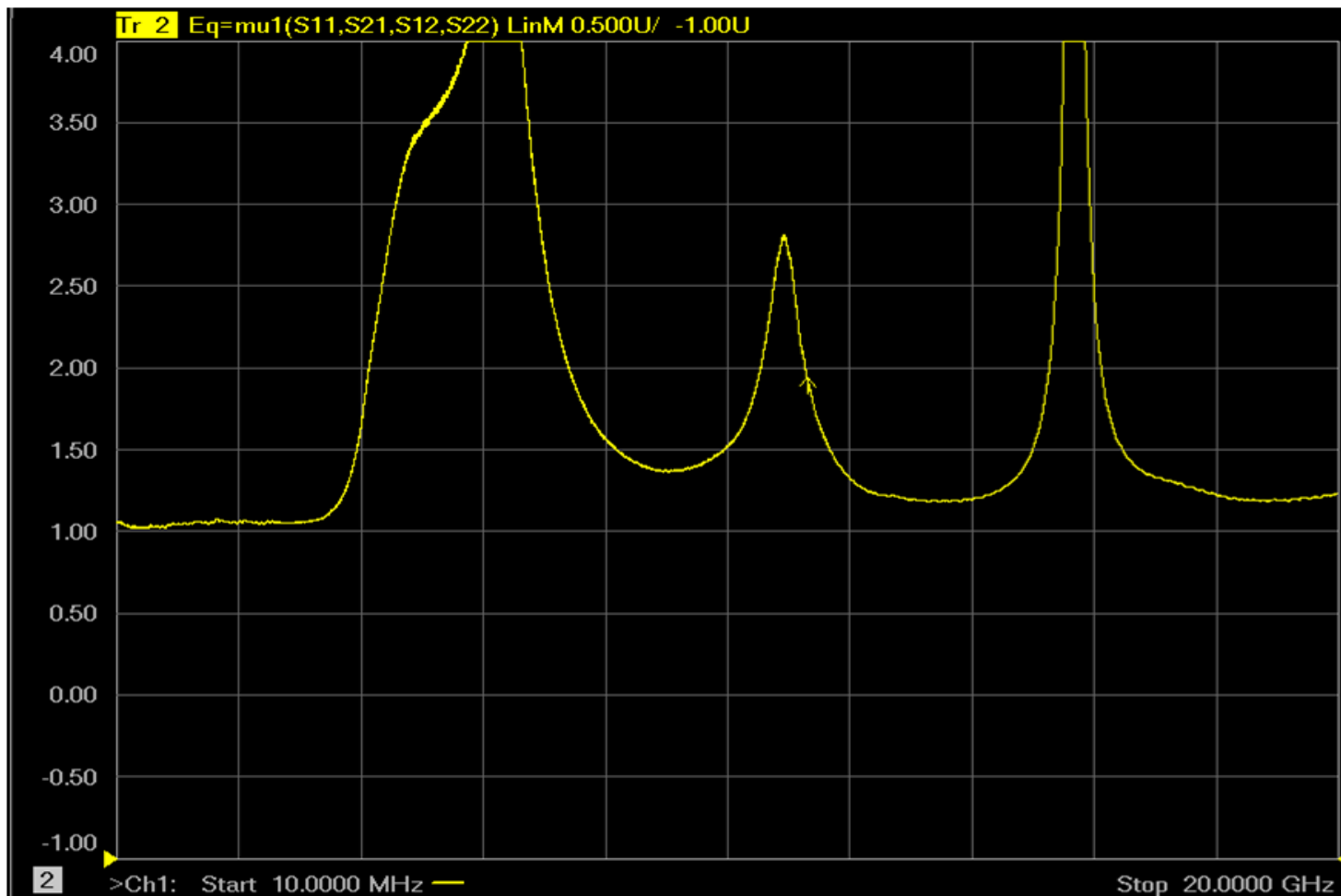

Note: Mu factor  $\geq 1.0$  implies unconditional stability.

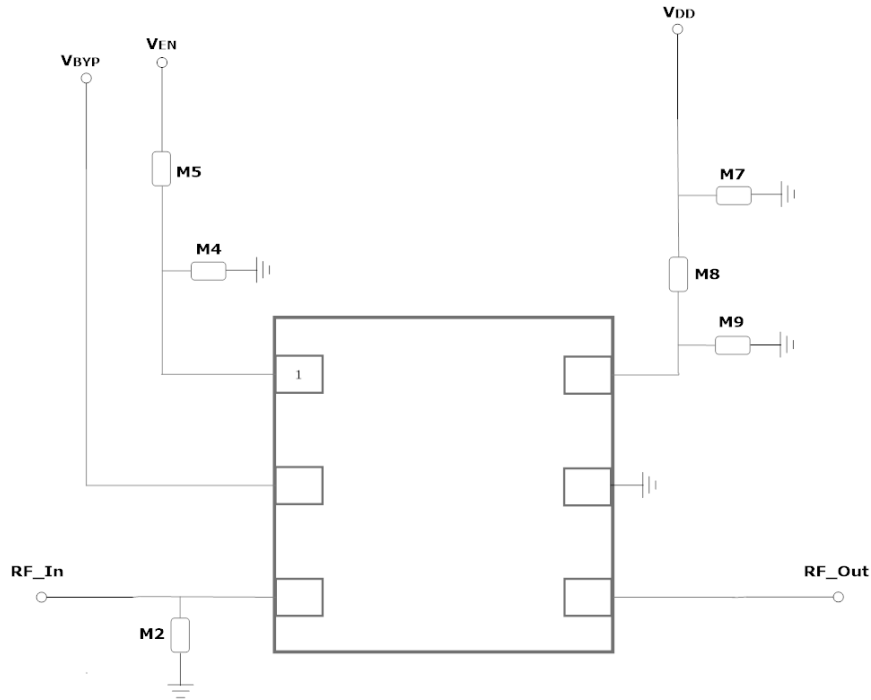

GRF2541 Application Schematic

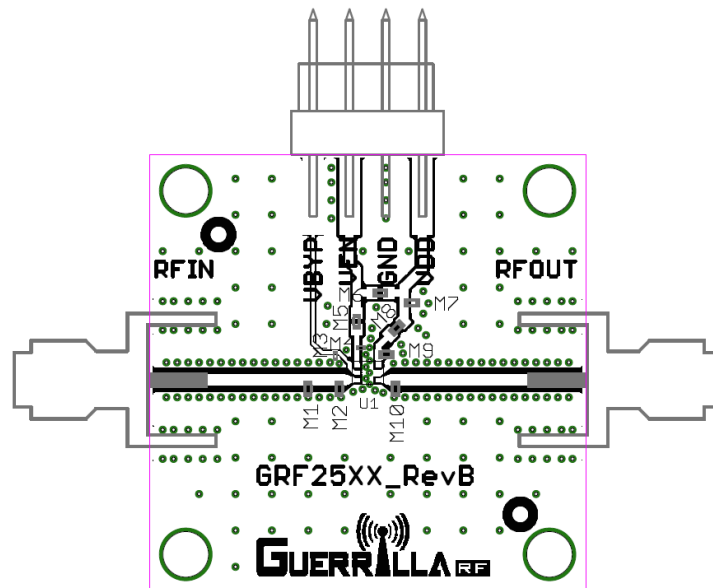

GRF2541 Evaluation Board Assembly Diagram



**Preliminary High Gain, Ultra-LNA w/Bypass**  
**802.11ac: 4.9–6.0 GHz**

# GRF2541

## GRF2541 Standard Evaluation Board BOM: (5.1 to 5.9 GHz Tune)

Component	Type	Manufacturer	Family	Value	Package Size	Substitution
M2	Capacitor	Murata	GJM	0.2 pF	0402	ok
M4	Capacitor	Murata	GRM	100 pF	0402	ok
M5	Resistor: 5%	Various	—	0 Ohm	0402	ok
M7	Capacitor	Murata	GRM	0.1 uF	0402	ok
M8	Ferrite Bead	Murata	BLM15AG121SN1D	—	0402	ok
M8 (See Note)	Resistor	Various	—	15 Ohm	0402	ok
M9	Capacitor	Murata	GJM	2.0 pF	0402	ok
Evaluation Board:	GRF25XX_RevB					

**Note: 15 Ohm resistor can be used instead of ferrite bead at position M8. Ferrite bead will provide better gain suppression below 2 GHz.**

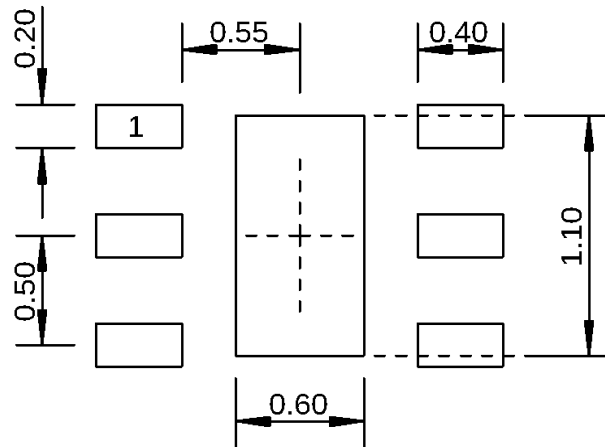

Dimensions in millimeters

### 1.5 mm DFN-6 Suggested PCB Footprint (Top View)

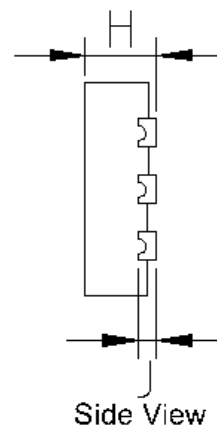
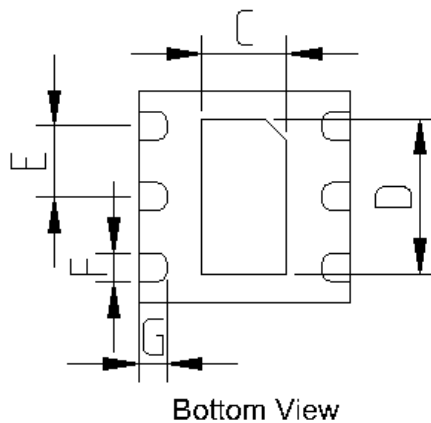
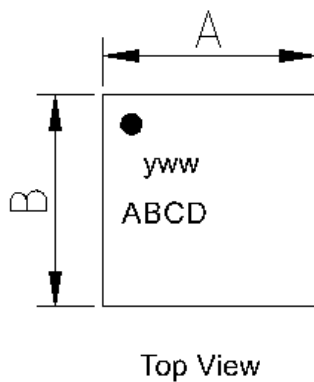

Dimensions (MM)	
A	1.5 +/- 0.050
B	1.5 +/- 0.050
C	.6 +/- 0.050
D	1.1 +/- 0.050
E	.5 Bsc
F	.2 +/- 0.050
G	.2 +/- 0.050
H	.45 +/- 0.050
J	.12 Ref.

### 1.5 mm DFN-6 Package Dimensions