



Features

Reference: 5.0V/25mA/10.0 GHz

- Gain: 13.2 dB
- EVB NF: 1.9 dB
- OP1dB: 12.8 dBm
- OIP3: 24.0 dBm
- Flexible Bias Voltage and Current
- Process: GaAs pHEMT

Applications

- X-Band LNA
- Microwave Oscillator
- LO Buffer
- RFID
- Motion Detectors
- Microwave Backhaul

Product Description

GRF2710 is a high gain, low noise, linear amplifier designed for high performance 8.0 to 12.0 GHz X-band applications. Over this frequency range, it exhibits excellent gain and compression point.

The device is operated from a single positive supply of 3.0 to 5.0 V with a typical bias condition of 5.0 V and 25 mA. The application schematic requires a minimal number of matching components to cover the 8.0 to 12.0 GHz band.

Consult with the GRF applications engineering team for custom tuning/evaluation board data and device s-parameters are located on the website landing page.

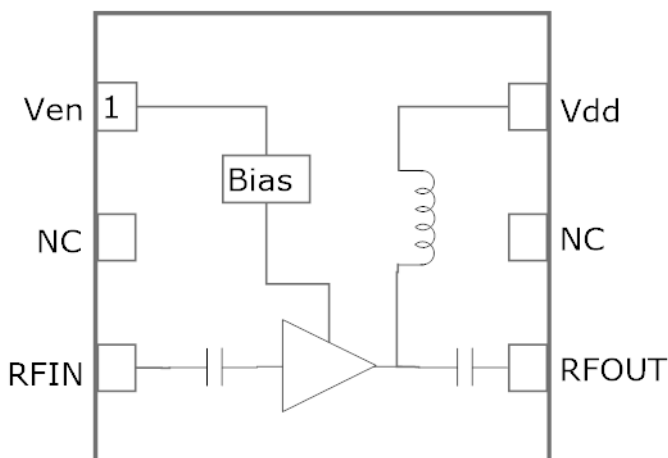

1.5 x 1.5 mm DFN-6

Absolute Ratings:

Parameter	Symbol	Min.	Max.	Unit
Supply Voltage	V _{DD}	0	6.0	V
RF Input Power: (Load VSWR < 2:1; V _D : 5.0 volts)	P _{IN MAX}		15	dBm
Operating Temperature (Package Heat Sink)	T _{AMB}	-40	105	°C
Maximum Channel Temperature (MTTF > 10 ⁶ Hours)	T _{MAX}		170	°C
Maximum Dissipated Power	P _{DISS MAX}		300	mW
Electrostatic Discharge:				
Charged Device Model:	CDM	1500		V
Human Body Model:	HBM	250		V
Storage:				
Storage Temperature	T _{STG}	-65	150	°C
Moisture Sensitivity Level	MSL		1	--

Caution! ESD Sensitive Device



Exceeding Absolute Maximum Rating conditions may cause permanent damage to the device.

Note: For manufacturing information, see the Guerrilla-RF.com website for the following document located on the GRF2710 landing page: Manufacturing Note—MN-001 Product Tape and Reel, Solderability and Package Outline Specification.

[Link to manufacturing note:](#)

Pin Out (Top View)



Pin Assignments:

Pin	Name	Description	Note
1	V _{ENABLE}	LNA Enable Input	V _{ENABLE} and series resistor set I _{DDQ} . V _{ENABLE} < =0.2 volts disables device. On-die pull-down resistor will turn the part off if this node is allowed to float.
2	NC	No Connect or Ground	No internal connection to die
3	RF _{In}	LNA RF input	Internally pre-matched to 50 Ω. These ports may be DC connected to ground externally but no DC > 0.2 volts should be applied to these ports.
4	RF _{Out}	LNA RF output	
5	NC	No Connect or Ground	No internal connection to die
6	V _{DD}	Supply Voltage for the LNA	Requires bypass capacitance as close as possible to pin on PCB
PKG BASE	GND	Ground	Provides DC and RF ground for LNA, as well as thermal heat sink. Recommend multiple 8 mil vias beneath the package for optimal RF and thermal performance. Refer to evaluation board top layer graphic on schematic page.

V_{ENABLE} Truth Table:

V _{DD}	V _{ENABLE}	Mode
High	>=1.8 V	LNA On
High	<0.1 V	LNA Off



Released

GRF2710

High Gain, X-Band LNA
Tuning Range: 8.0 to 12.0 GHz

Nominal Operating Parameters:

Parameter	Symbol	Specification			Unit	Condition
		Min.	Typ.	Max.		
High Gain Mode						
V _{DD} = 5.0V, T _A = 25 °C						
Test Frequency	F _{TEST}		10.0		GHz	
Gain	S ₂₁	11.7	13.2		dB	
Evaluation Board Noise Figure	NF		1.9	2.3	dB	
Output 3rd Order Intercept Point	OIP ₃		24.0		dBm	
Output 1dB Compression	OP _{1dB}	10.8	12.8		dBm	
Supply Current (Quiescent)	I _{DD}		25.0		mA	
Switching Rise Time	T _{RISE}		300		ns	
Switching Fall Time	T _{FALL}		100		ns	
Enable Current	I _{ENABLE}		1.5		mA	
Disabled Mode						
V _{DD} = 5.0 V, V _{ENABLE} = 0.0V						
Supply Current (Leakage)	I _{DD}		160		μA	
Thermal Data						
Thermal Resistance (Infra-Red Scan)	Θ _{jc}		141		°C/W	
Channel Temperature @ +85 C reference (Package heat sink)	T _{CHANNEL}		103 (See note)		°C	V _{DD} : 5.0V; I _{DDQ} : 25 mA; No RF P _{DISS} : 125 mA

Note: MTTF >10⁶ hours for T_{CHANNEL} < =170 degrees C.



Released

GRF2710

High Gain, X-Band LNA
Tuning Range: 8.0 to 12.0 GHz

GRF2710 Evaluation Board Data:

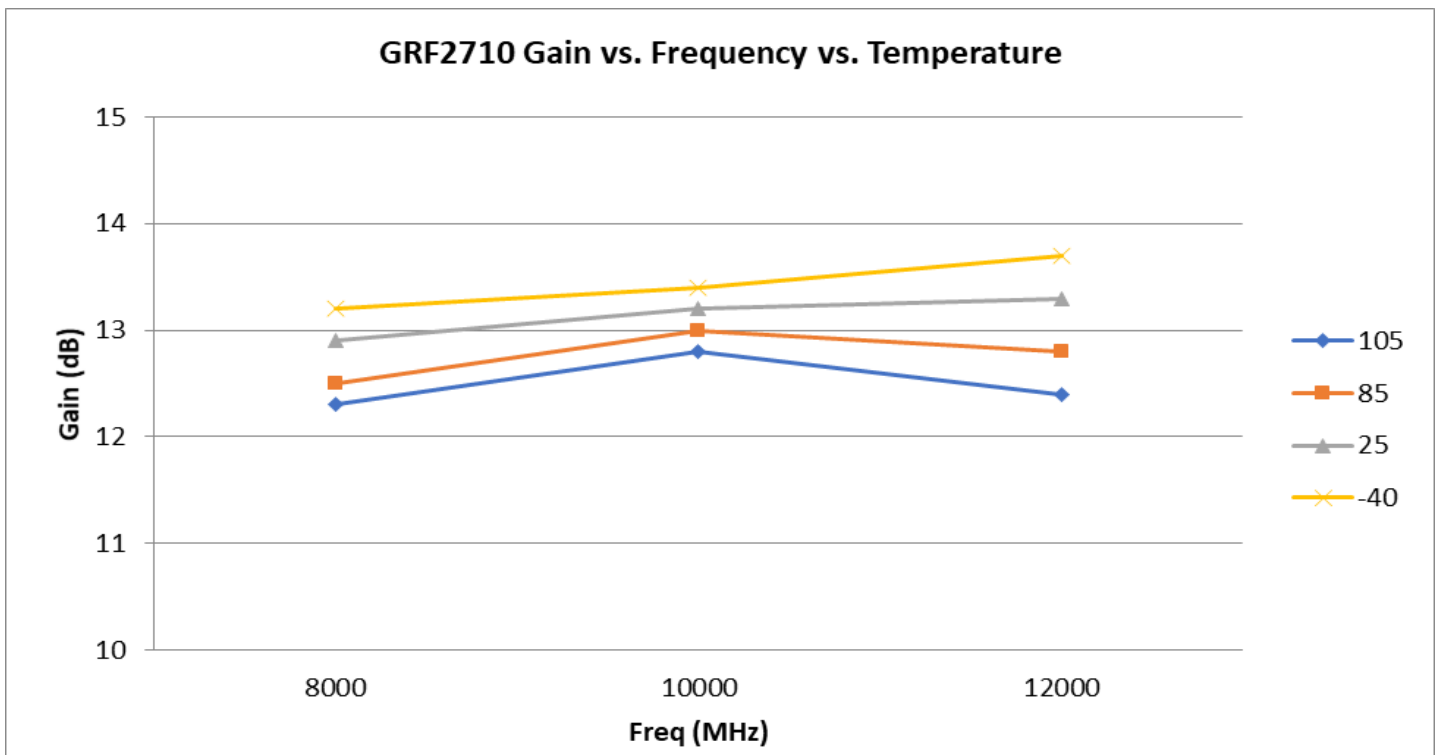
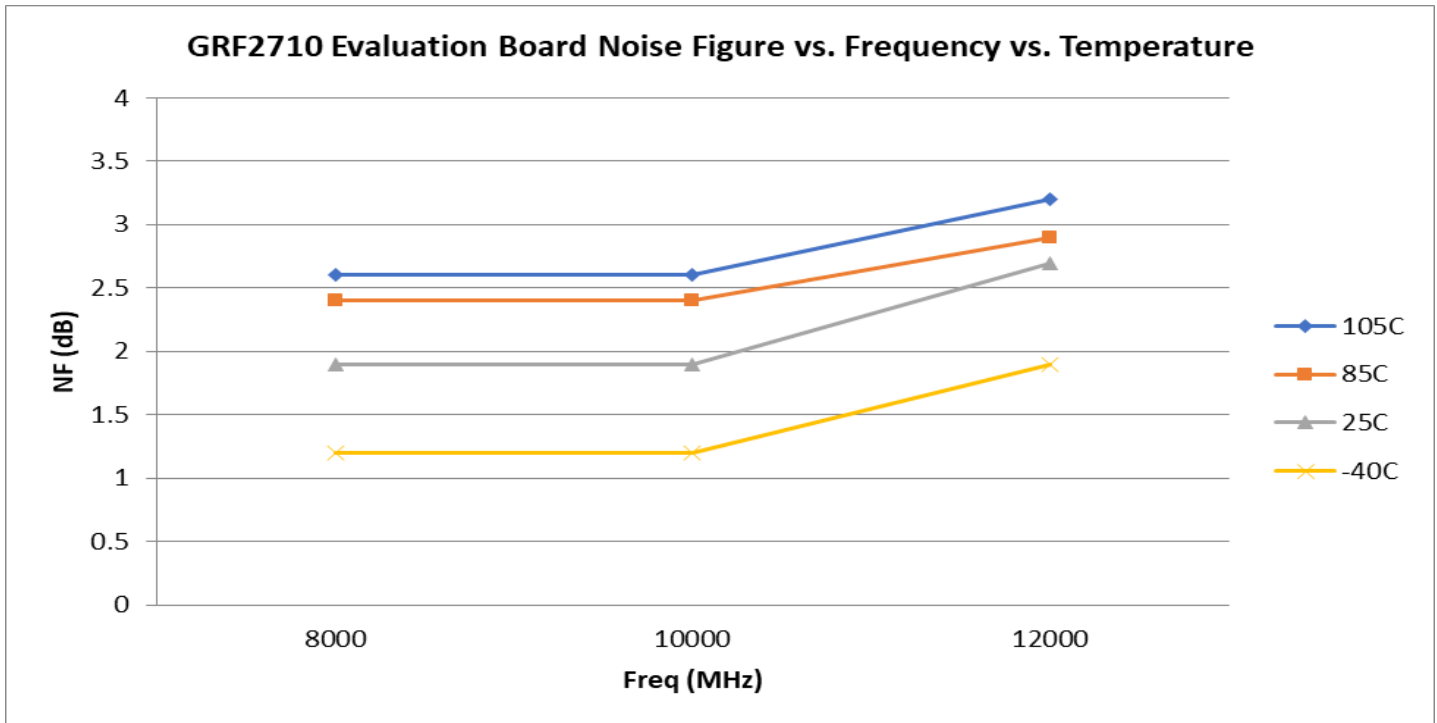



Released

GRF2710

High Gain, X-Band LNA
Tuning Range: 8.0 to 12.0 GHz

GRF2710 Evaluation Board Data:

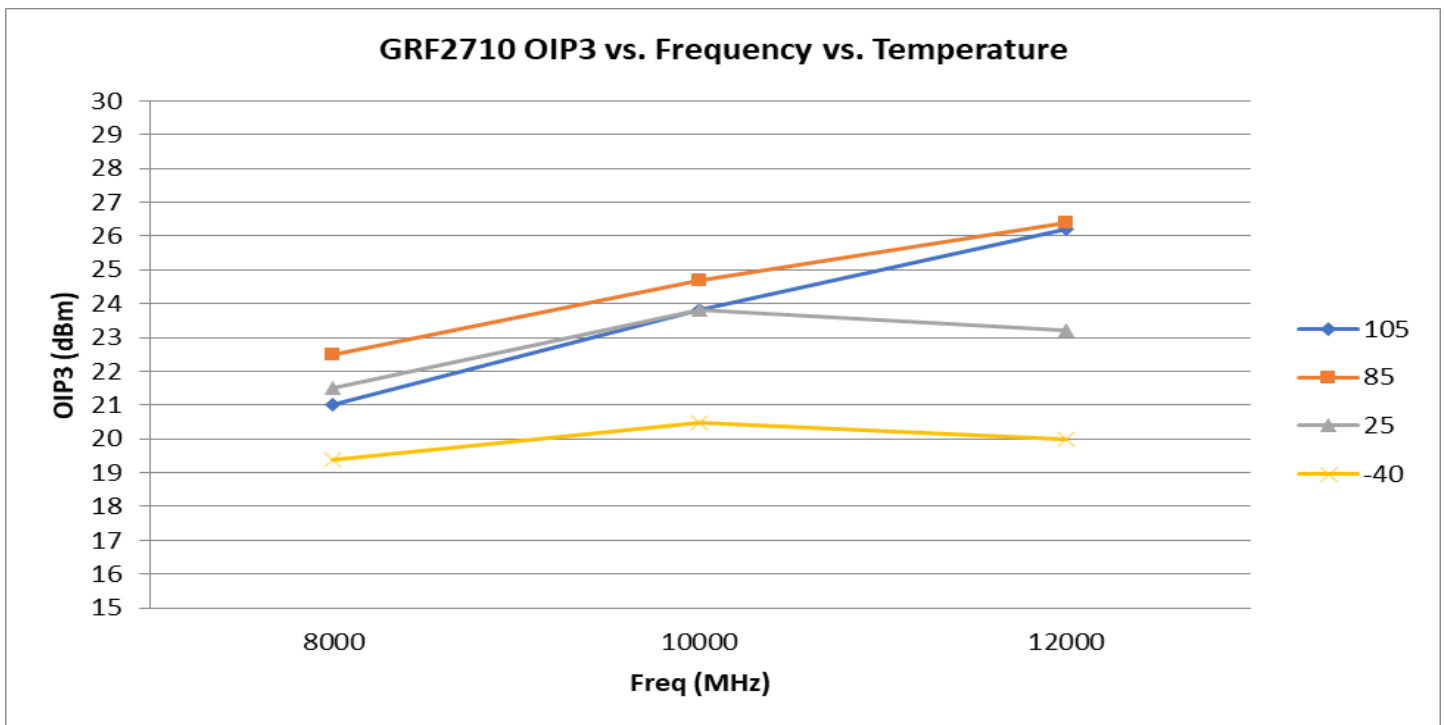
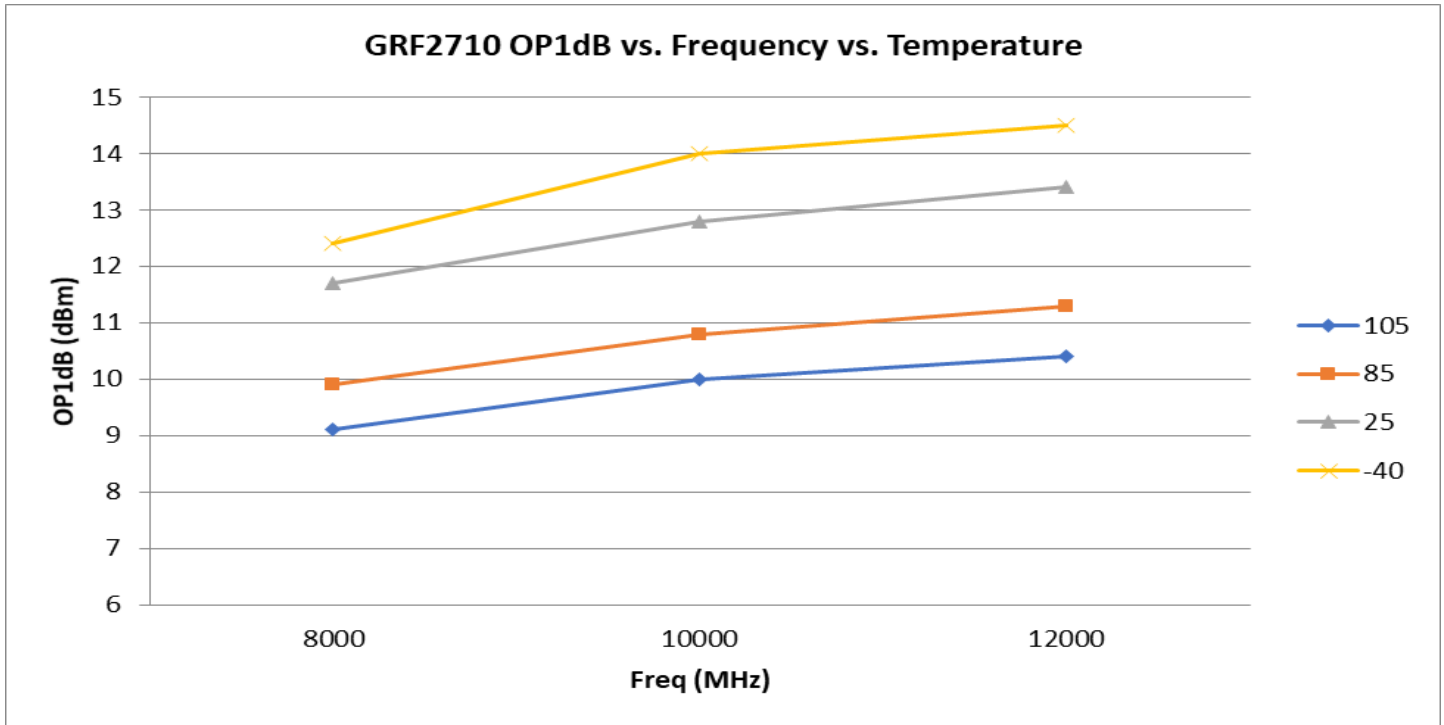



Released

GRF2710

High Gain, X-Band LNA
Tuning Range: 8.0 to 12.0 GHz

GRF2710 Evaluation Board S-Parameters and Stability Mu Factor:

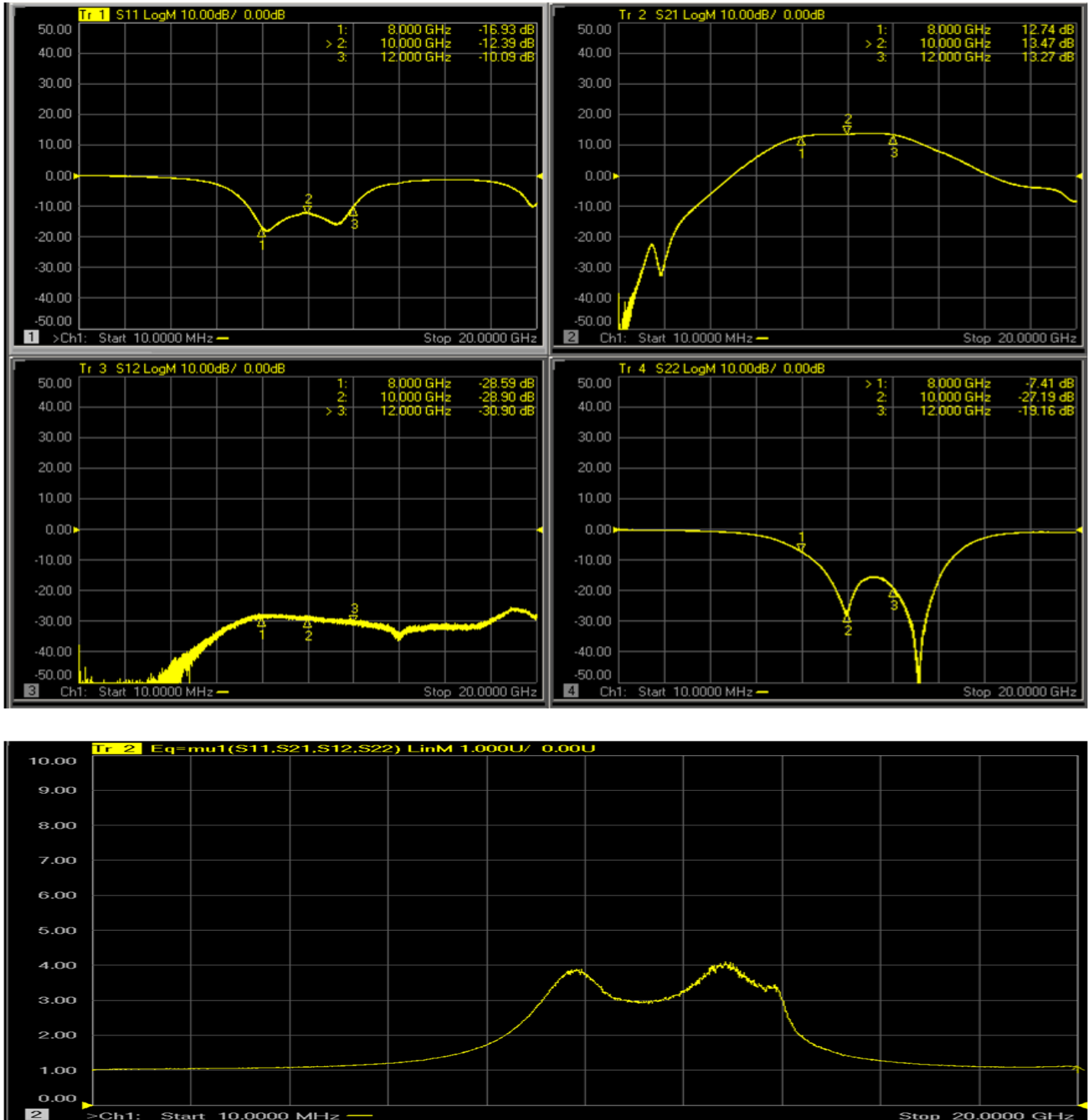

Note: $\mu \geq 1.0$ implies unconditional stability

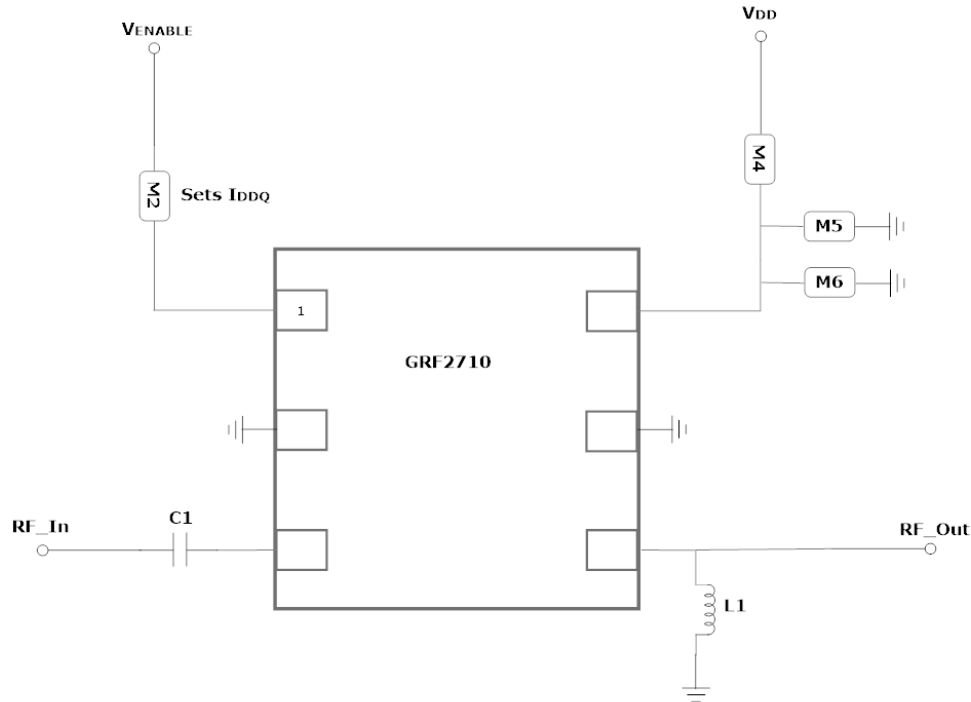

GRF2710 Standard Application Schematic

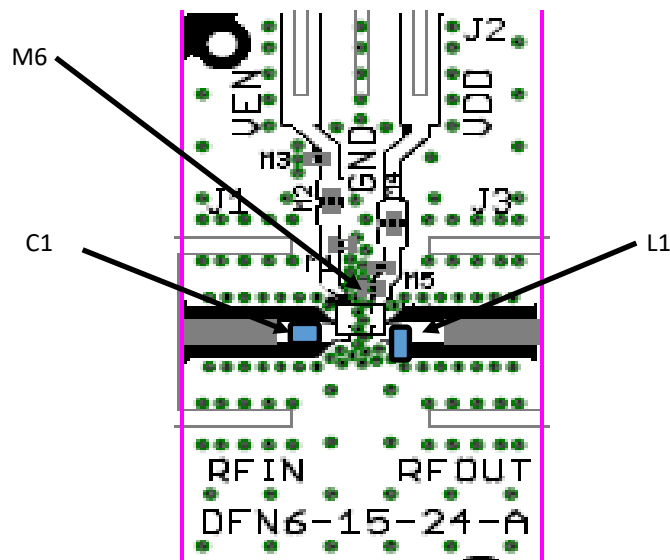

GRF2710 Evaluation Board Assembly Diagram



Released

GRF2710

High Gain, X-Band LNA
Tuning Range: 8.0 to 12.0 GHz

GRF2710 Standard Evaluation Board BOM; 8 to 12 GHz

Component	Type	Manufacturer	Family	Value	Package Size	Substitution
C1 (Close to pin 3)	Capacitor	Murata	GJM	0.7 pF	0402	ok
M2 (See curves)	Resistor	Various	5%	Sets Iddq	0402	ok
M4	0 Ohm Jumper	—	—	—	0402	ok
M5	Capacitor	Murata	GRM	0.1 uF	0402	ok
M6 (Close to pin 6)	Capacitor	Murata	GJM	10 pF	0402	ok
L1 (Close to pin 4)	Inductor	Murata	LQP	1.8 nH	0402	ok
Evaluation Board	DFN6-15-24-A					

GRF2710 Bias Resistor Selection Curves

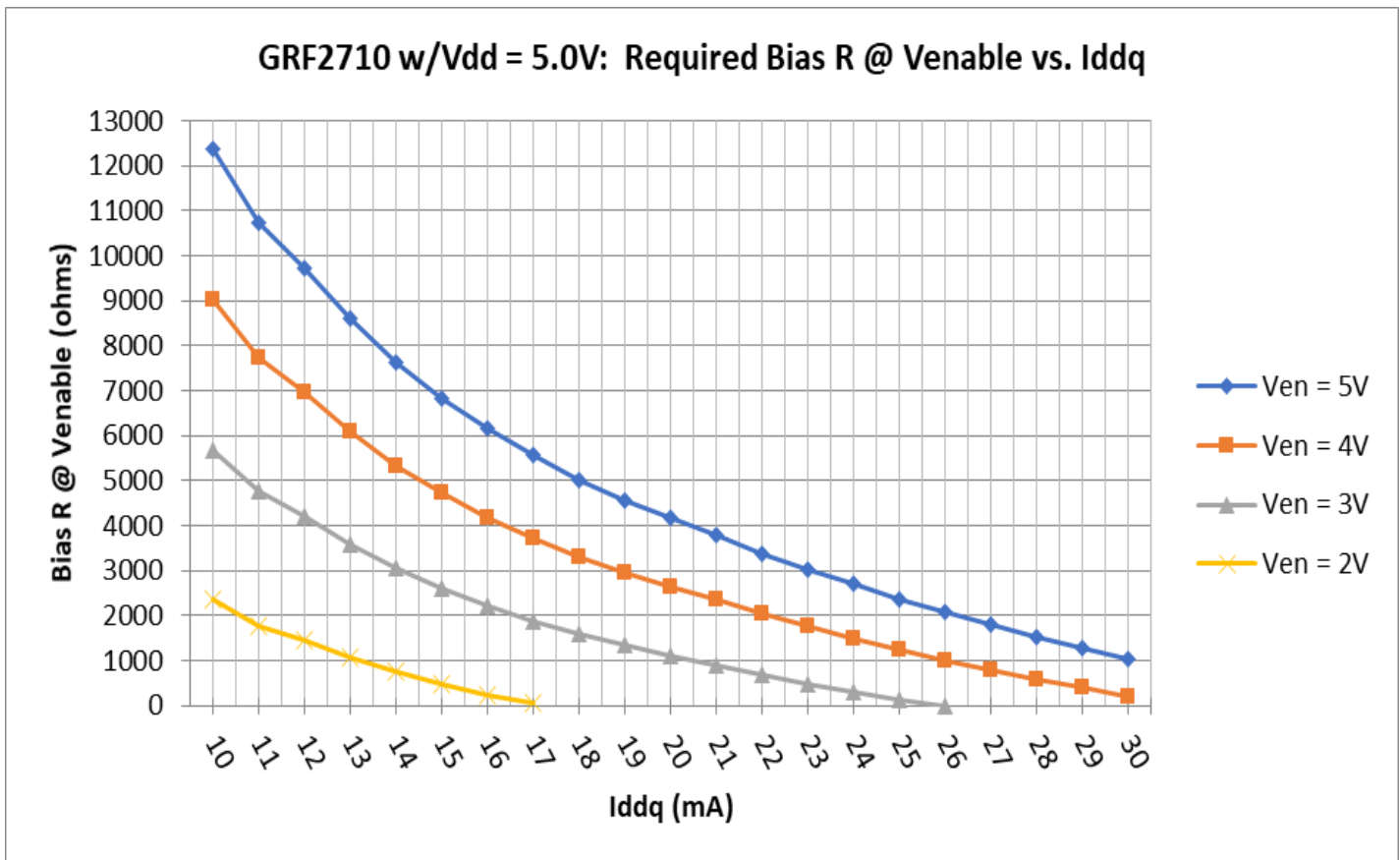

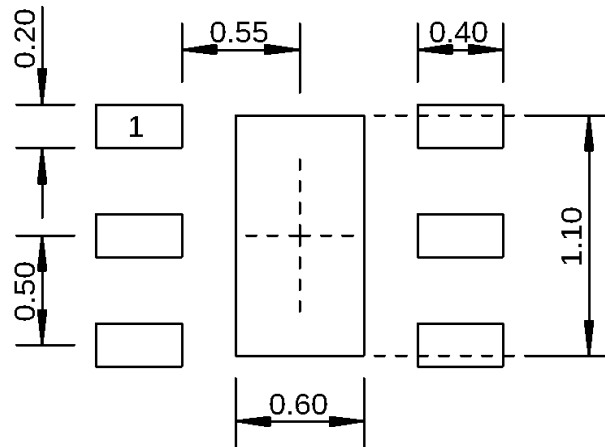

Dimensions in millimeters

1.5 mm DFN-6 Suggested PCB Footprint (Top View)

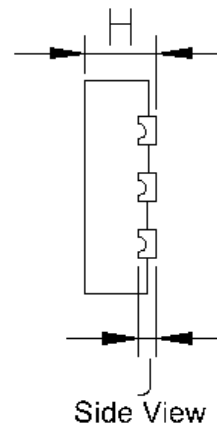
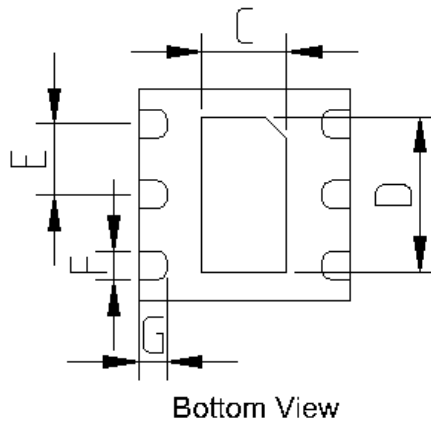
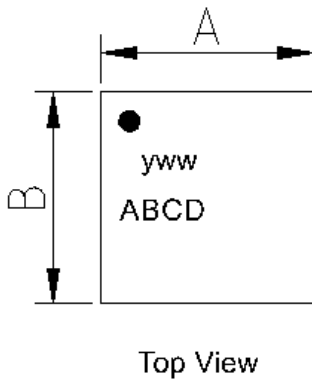

Dimensions (MM)	
A	1.5 +/- 0.050
B	1.5 +/- 0.050
C	.6 +/- 0.050
D	1.1 +/- 0.050
E	.5 Bsc
F	.2 +/- 0.050
G	.2 +/- 0.050
H	.45 +/- 0.050
J	.12 Ref.

1.5 mm DFN-6 Package Dimensions

Tape and Reel Information:

Guerrilla RF's Tape and Reel specification complies with the Electronics Industries Association (EIA) standards for 'Embossed Carrier Tape of Surface Mount Components for Automatic Handling'. Reference EIA-481. See the table on the following page for Tape and Reel specifications along with units per reel.

Devices are loaded with pins down into the carrier pocket with protective cover tape, wound into a plastic reel. Each reel will be packaged in a cardboard box. There will be product labels on the reel, the protective ESD bag and the outside surface of the box.

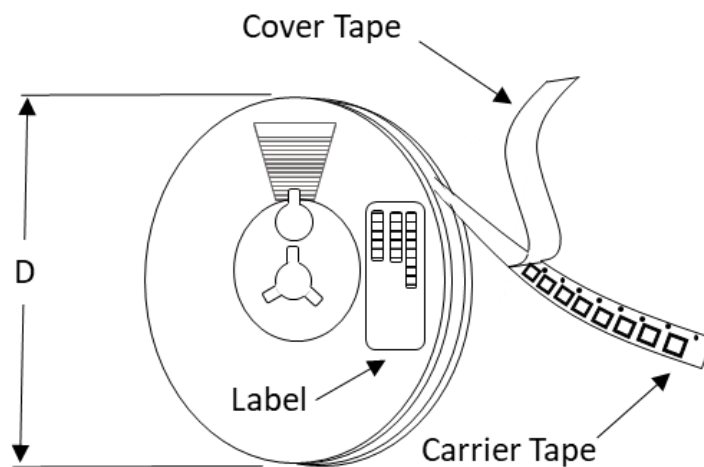

Tape and Reel Packaging with Reel Diameter Noted (D)

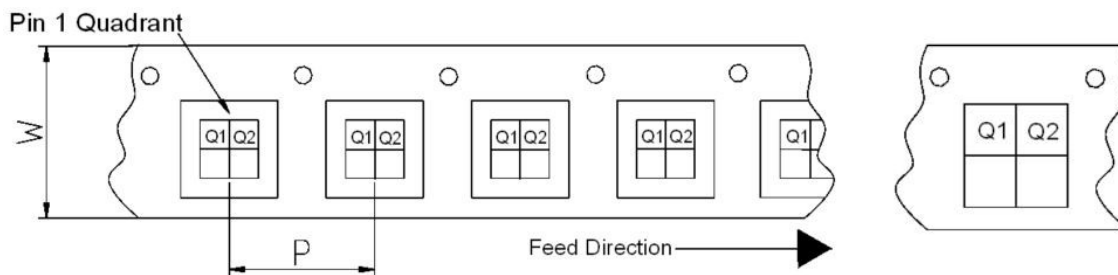

Carrier Tape Width (W), Pitch (P), Feed Direction and Pin 1 Quadrant Information



Released

GRF2710

High Gain, X-Band LNA
Tuning Range: 8.0 to 12.0 GHz

Tape and Reel Specification and Device Package Information Table

Package				Carrier Tape			Reel	
Type	Dimensions (mm)	Leads	Weight (mg)	Width (W) (mm)	Pocket Pitch (P) (mm)	Pin 1 Quadrant	Diameter (D) (inches)	Units per Reel
QFN	2.0 x 2.0 x 0.50	12	7	8	4	Q1	7	2500
QFN	3.0 x 3.0 x 0.85	16	24	12	8	Q1	7	1500
DFN	1.5 x 1.5 x 0.45	6	4	8	4	Q1	7	2500
DFN	2.0 x 2.0 x 0.75	8	12	8	4	Q1	7	2500
LFM	3.5 x 3.5 x 0.75	See note	TBD	12	8	Q2	7	1500
LFM	4.0 x 4.0 x 0.75	See note	TBD	12	8	Q2	7	1500

Note: Lead count may vary. Reference applicable product data sheet