



Released

GRF5010

28.5 dBm Power-LNA™
Tuning Range: 0.05 – 6.0 GHz



Features

Reference: 8V/95mA/2.5GHz

- Gain: 17.0 dB
- NF: 0.85 dB
- OP1dB: 28.5 dBm
- OIP3: 45.0 dBm

Reference: 5V/60mA/2.5GHz

- Gain: 17.0 dB
- NF: 0.82 dB
- OP1dB: 24.5 dBm
- OIP3: 38.5 dBm
- Flexible Bias Voltage and Current
- Process: GaAs pHEMT

Applications

- Multi-stage LNA
- Linear Driver Amplifier for High PAR Waveforms
- Distributed Antenna Systems
- Microwave Backhaul

Product Description

GRF5010 is a high linearity PA with ultra-low noise figure (NF). The primary tune for this device covers 1.7 to 3.8 GHz and it achieves outstanding P1dB, IP3 and NF over the band. The device can be tuned to deliver outstanding performance over 0.1 GHz. to 6.0 GHz with fractional bandwidths >30%. With an 8.0 Volt supply, the device can deliver broadband OP1dB values greater than 28.0 dBm.

In addition to use as a PA or linear driver, GRF5010 is well suited to demanding first, second or third stage LNA applications requiring high linearity, ruggedness and low NF.

Consult with the GRF applications engineering team for custom tuning/evaluation board data and device s-parameters.

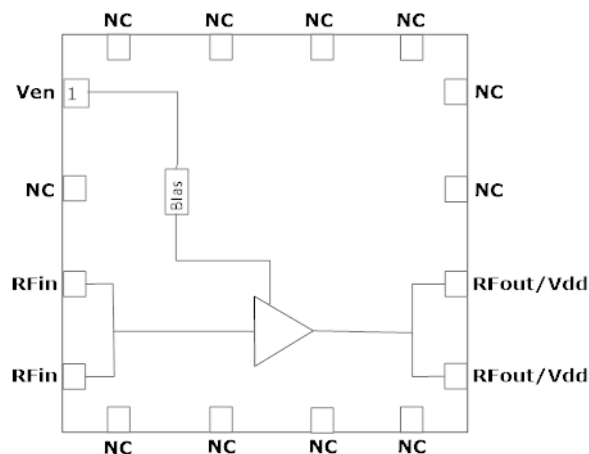

3.0 x 3.0 mm QFN-16



Released

GRF5010

28.5 dBm Power-LNA™
Tuning Range: 0.05 – 6.0 GHz

Absolute Ratings:

Parameter	Symbol	Min.	Max.	Unit
Drain Voltage	V _{DD}		10.0	V
Transient Average RF Input Power: (Load VSWR < 2:1; Duration: <1 hour)	P _{IN MAX}		22.0	dBm
Average RF Output Power: (Load VSWR < 2:1; V _D : > 8.0 volts; Duration: Continuous)	P _{OUT MAX}		26.0	dBm
Average RF Output Power: (Load VSWR < 2:1; V _D : ≤ 8.0 volts; Duration: Continuous)	P _{OUT MAX}		NA	dBm
Operating Temperature (Package Heat Sink)	T _{AMB}	-40	105	°C
Maximum Channel Temperature (MTTF > 10 ⁶ Hours)	T _{MAX}		170	°C
Maximum Dissipated Power	P _{DISS MAX}		1.5	W
Electrostatic Discharge:				
Charged Device Model:	CDM	1000		V
Human Body Model:	HBM	250		V
Storage:				
Storage Temperature	T _{STG}	-65	150	°C
Moisture Sensitivity Level	MSL		1	--



Caution! ESD Sensitive Device



Exceeding Absolute Maximum Rating conditions may cause permanent damage to the device.

Note: For package dimensions and manufacturing information, see the Guerrilla-RF.com website for the following document located on the GRF5010 landing page: Manufacturing Note—MN-001 Product Tape and Reel, Solderability and Package Outline Specification.

[Link to manufacturing note](#)

Pin Out (Top View)

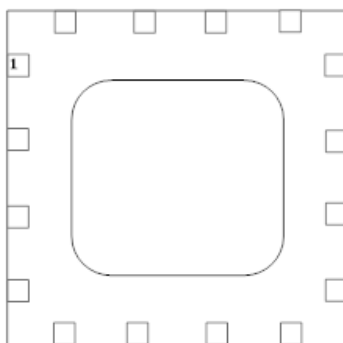

Pin Assignments:

Pin	Name	Description	Note
1	V _{ENABLE}	Enable Voltage Input	V _{ENABLE} and series resistor set I _{DDQ} . V _{ENABLE} < =0.2 volts disables device. On-die pull-down resistor will turn the part off if this node is allowed to float.
2	NC	No Connect or Ground	No internal connection to die
3	RF_In	RF Input	Pins 3-4 tied together on system board
4	RF_In	RF Input	Pins 3-4 tied together on system board
5	NC	No Connect or Ground	No internal connection to die
6	NC	No Connect or Ground	No internal connection to die
7	NC	No Connect or Ground	No internal connection to die
8	NC	No Connect or Ground	No internal connection to die
9	RF_Out/V _{DD}	PA Output/Bias	Pins 9-10 tied together on system board. Supply V _{dd} here.
10	RF_Out/V _{DD}	PA Output/Bias	Pins 9-10 tied together on system board. Supply V _{dd} here.
11	NC	No Connect or Ground	No internal connection to die
12	NC	No Connect or Ground	No internal connection to die
13	NC	No Connect or Ground	No internal connection to die
14	NC	No Connect or Ground	No internal connection to die
15	NC	No Connect or Ground	No internal connection to die
16	NC	No Connect or Ground	No internal connection to die
PKG BASE	GND	Ground	Provides DC and RF ground for LNA, as well as thermal heat sink. Recommend multiple 8 mil vias beneath the package for optimal RF and thermal performance. Refer to evaluation board top layer graphic on schematic page.



Released

GRF5010

28.5 dBm Power-LNA™
Tuning Range: 0.05 – 6.0 GHz

Nominal Operating Parameters:

Parameter	Symbol	Specification			Unit	Condition
		Min.	Typ.	Max.		
Target Performance (1.7-3.8 GHz Tune)						Bias: 8.0 V and 95 mA unless otherwise noted. (+25C)
Test Frequency	F _{TEST}		2.5		GHz	
Gain	S(2,1)	16.0	17.0		dB	
Noise Figure (Evaluation Board)	NF		0.85	1.05	dB	
Output 1dB Compression Point	OP1dB	26.5	28.5		dBm	
Output Third Order Intercept Point	OIP3		45.0		dBm	Tones: 2499 and 2501 MHz at +8.0 dBm per tone
Switching Rise Time	T _{RISE}		100		ns	
Switching Fall Time	T _{FALL}		100		ns	
Quiescent Supply Current	I _{DDQ}		95		mA	
Disabled Mode						V _{DD} : 8.0 volts; V _{ENABLE} : 0.0 volts
Supply Current (Leakage)	I _{DD}		350		uA	
Thermal Data						
Thermal Resistance: (IR Scan Method)	Θ _{JC}		45		°C/W	
Channel Temperature @ +85C Reference (package heat sink)	T _{CHANNEL}		119		°C	V _{DD} : 8.0 volts; I _{DDQ} : 95 mA P _{DISS} : 760 mW; No RF



Released

GRF5010

28.5 dBm Power-LNA™
Tuning Range: 0.05 – 6.0 GHz

GRF5010 Evaluation Board Data; Bias: 5.0V/60mA; (1.7 to 3.8 GHz Tune)

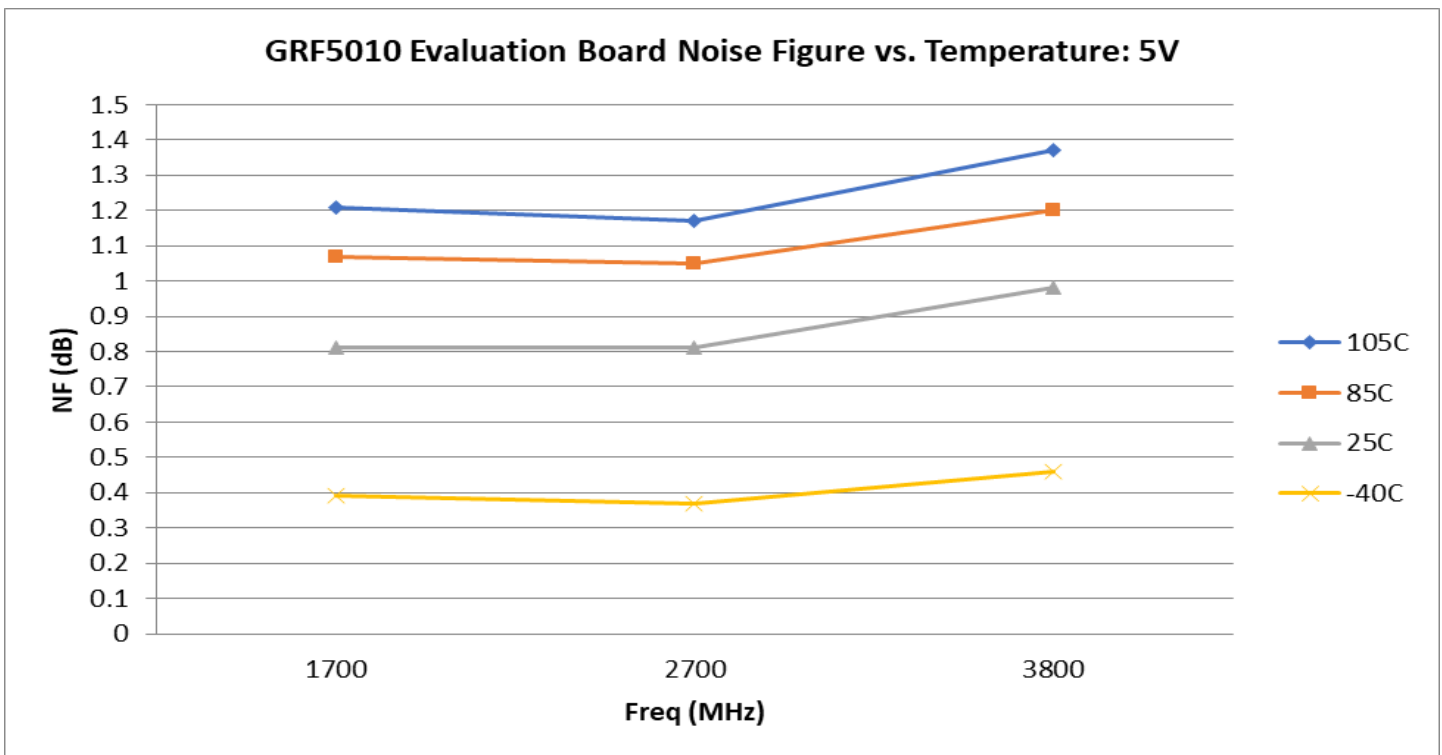
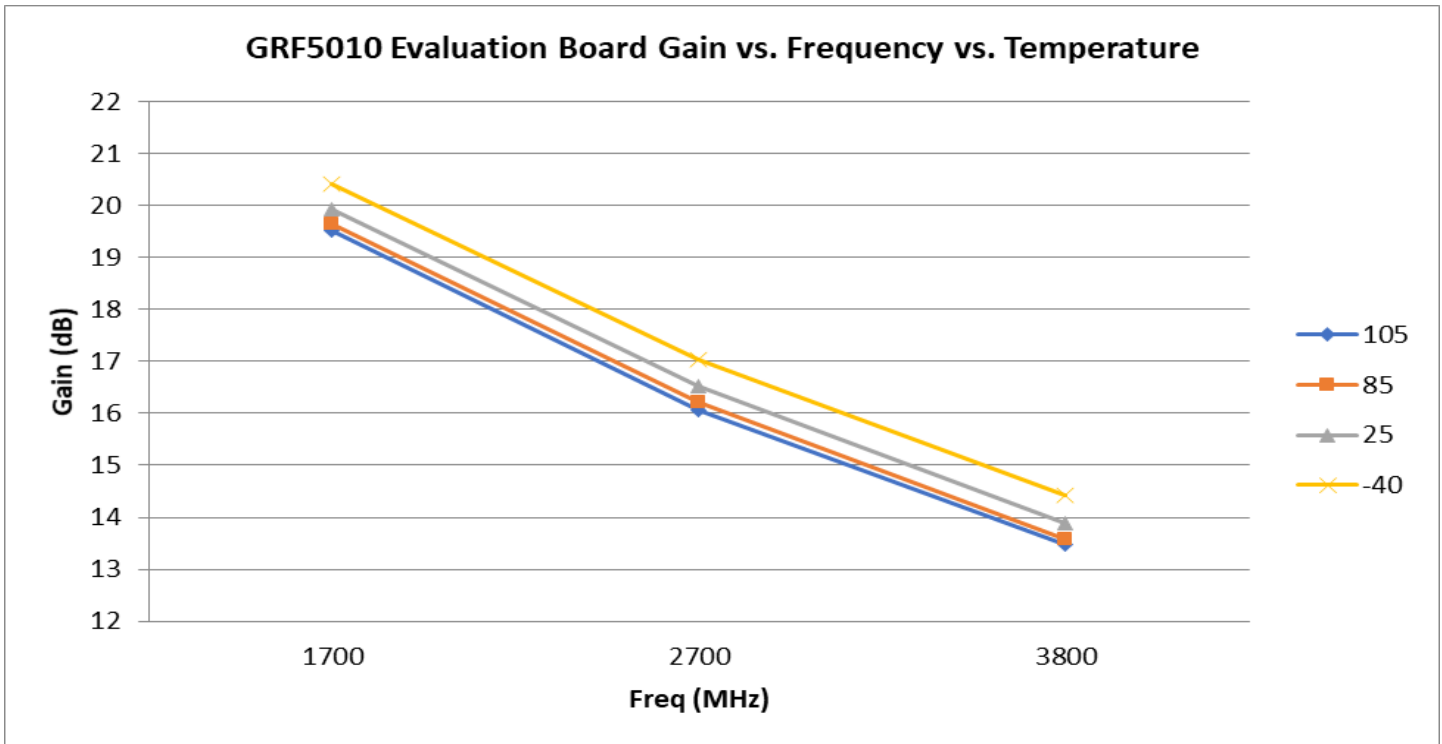



Released

GRF5010

28.5 dBm Power-LNA™

Tuning Range: 0.05 – 6.0 GHz

GRF5010 Evaluation Board Data; Bias: 5.0V/60mA; (1.7 to 3.8 GHz Tune)

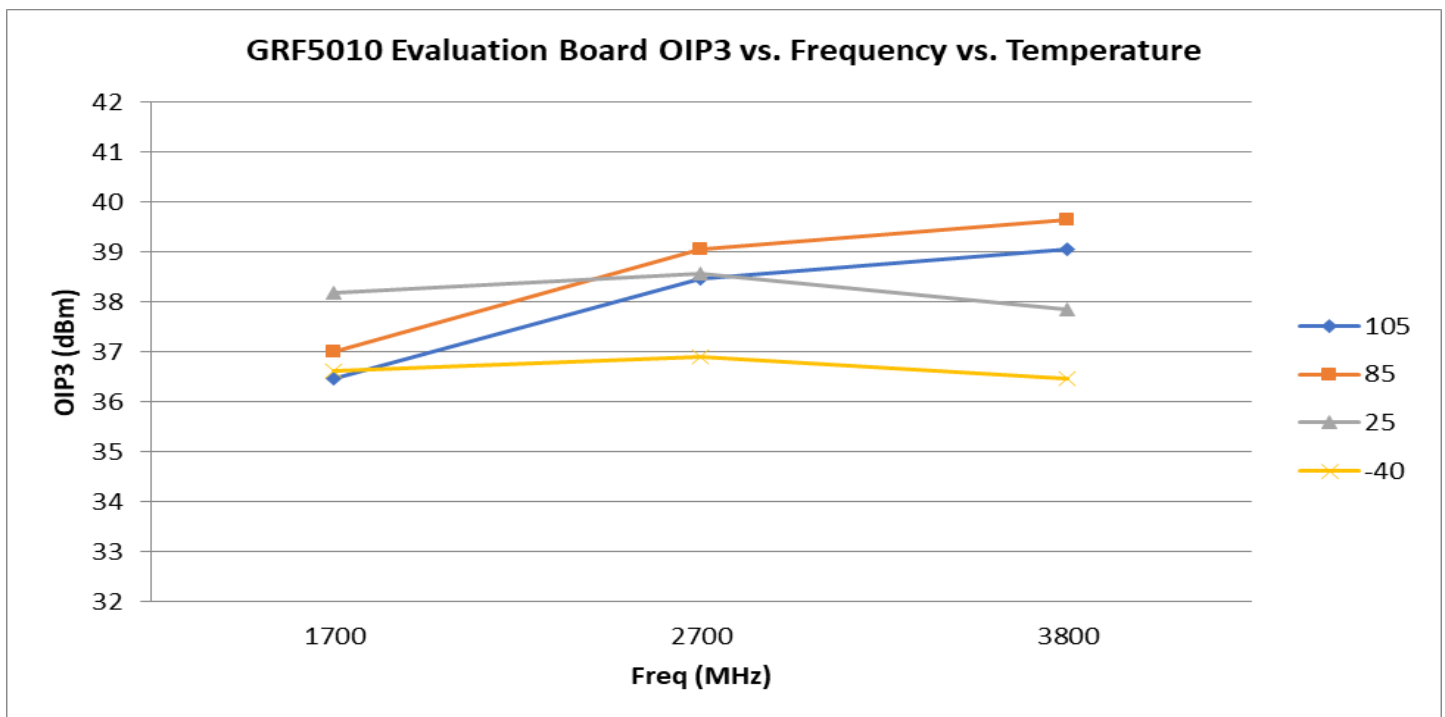
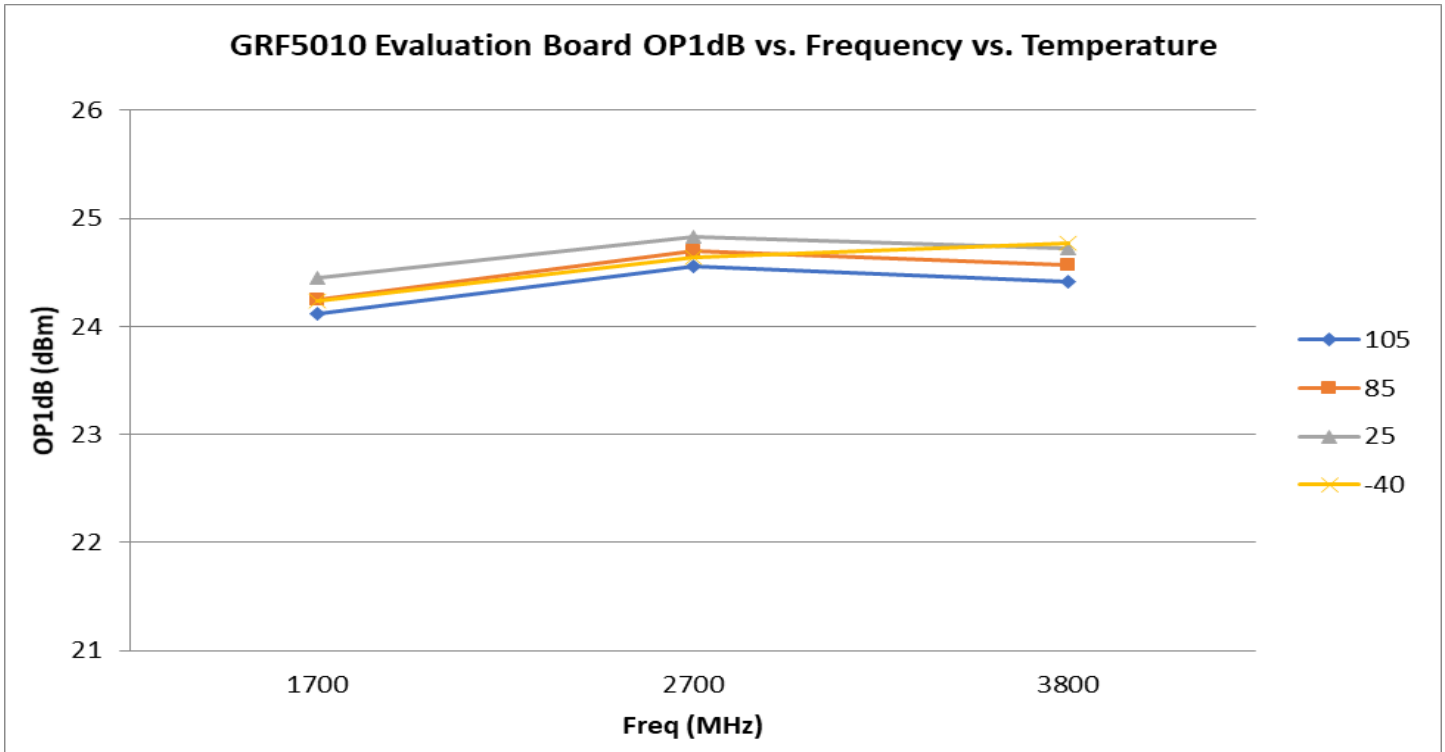



Released

GRF5010

28.5 dBm Power-LNA™
Tuning Range: 0.05 – 6.0 GHz

GRF5010 Evaluation Board Data; Bias: 8.0V/95mA; (1.7 to 3.8 GHz Tune)

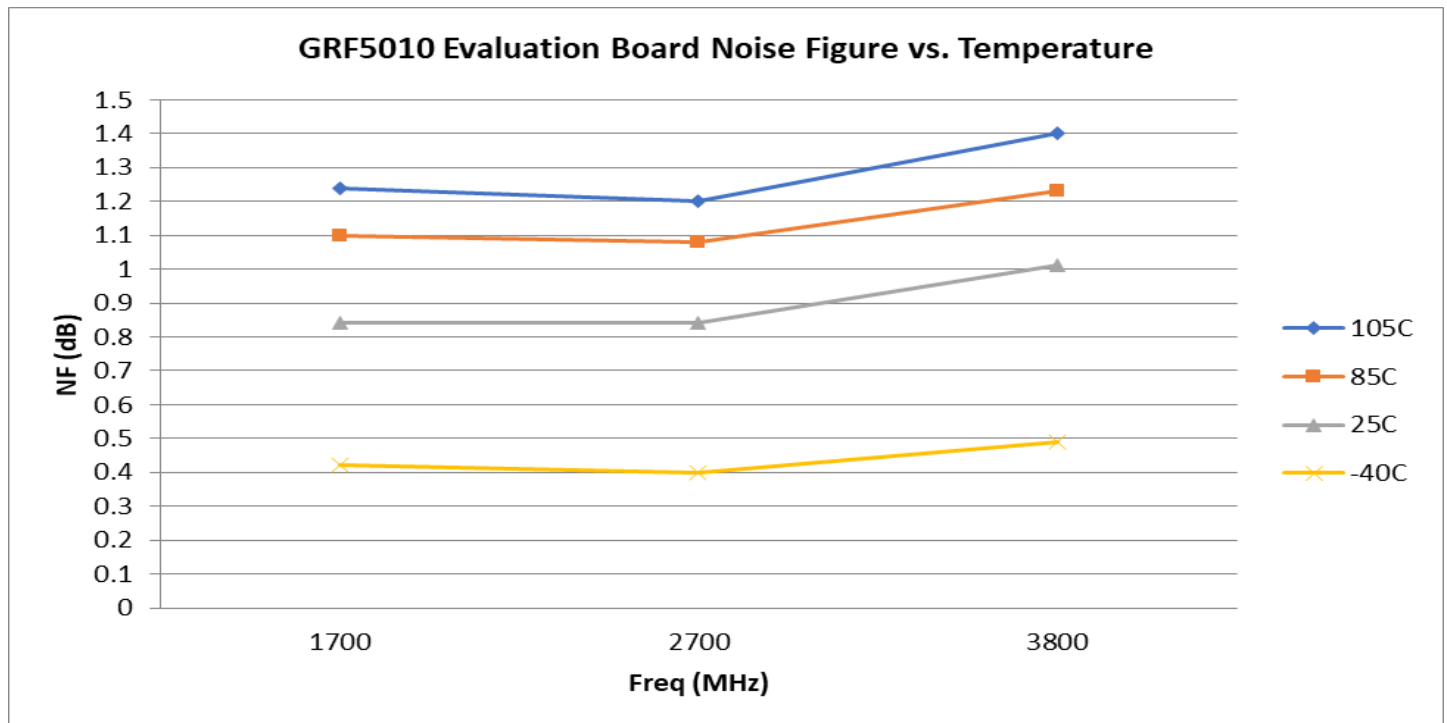
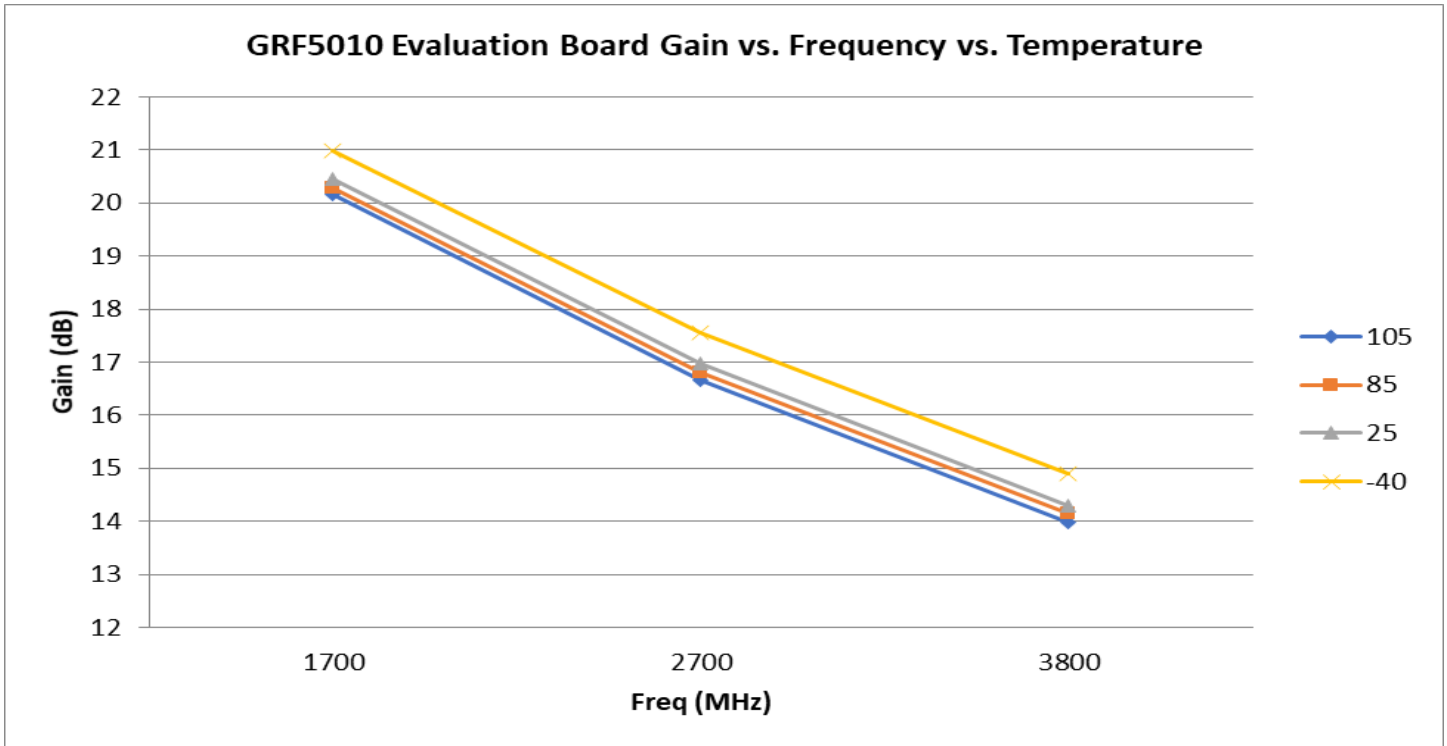



Released

GRF5010

28.5 dBm Power-LNA™
Tuning Range: 0.05 – 6.0 GHz

GRF5010 Evaluation Board Data; Bias: 8.0V/95mA; (1.7 to 3.8 GHz Tune)

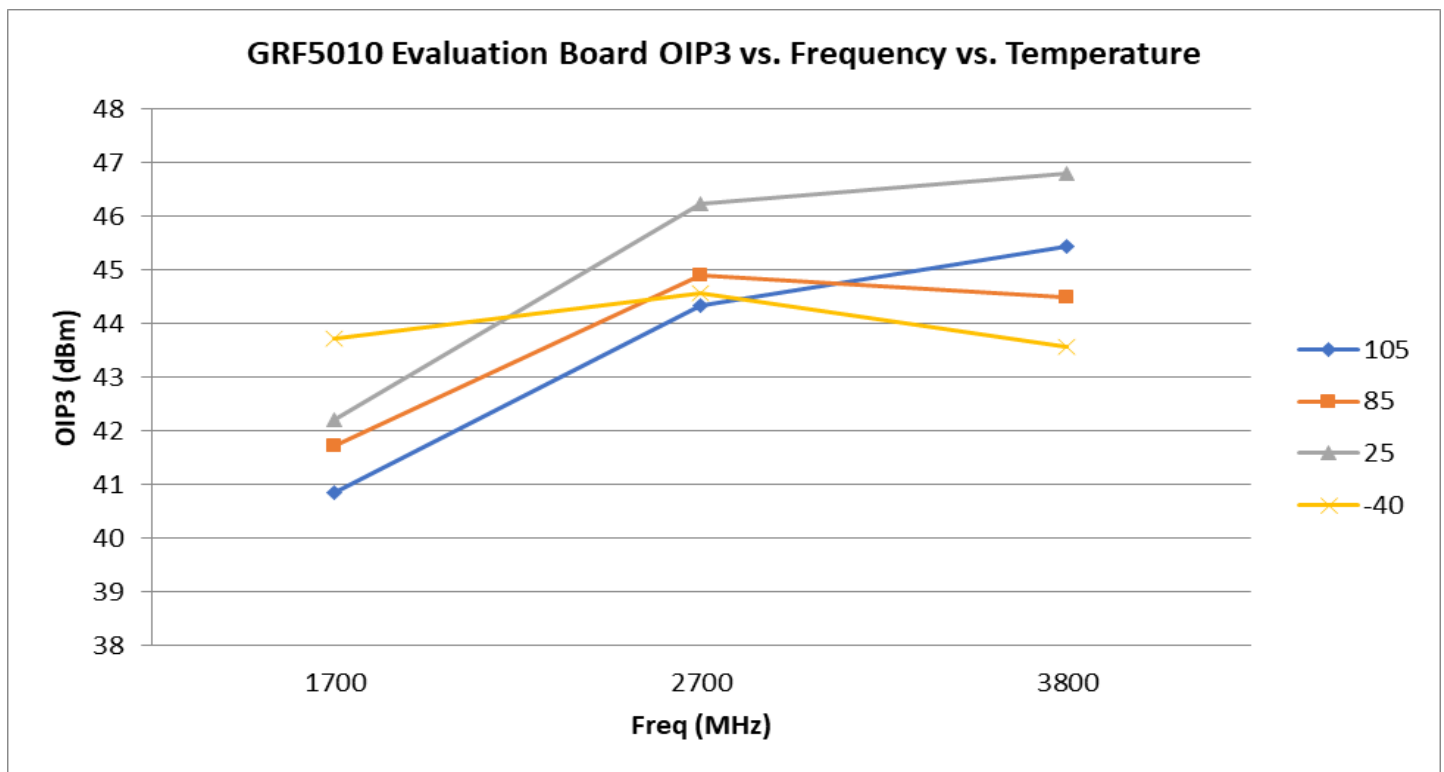
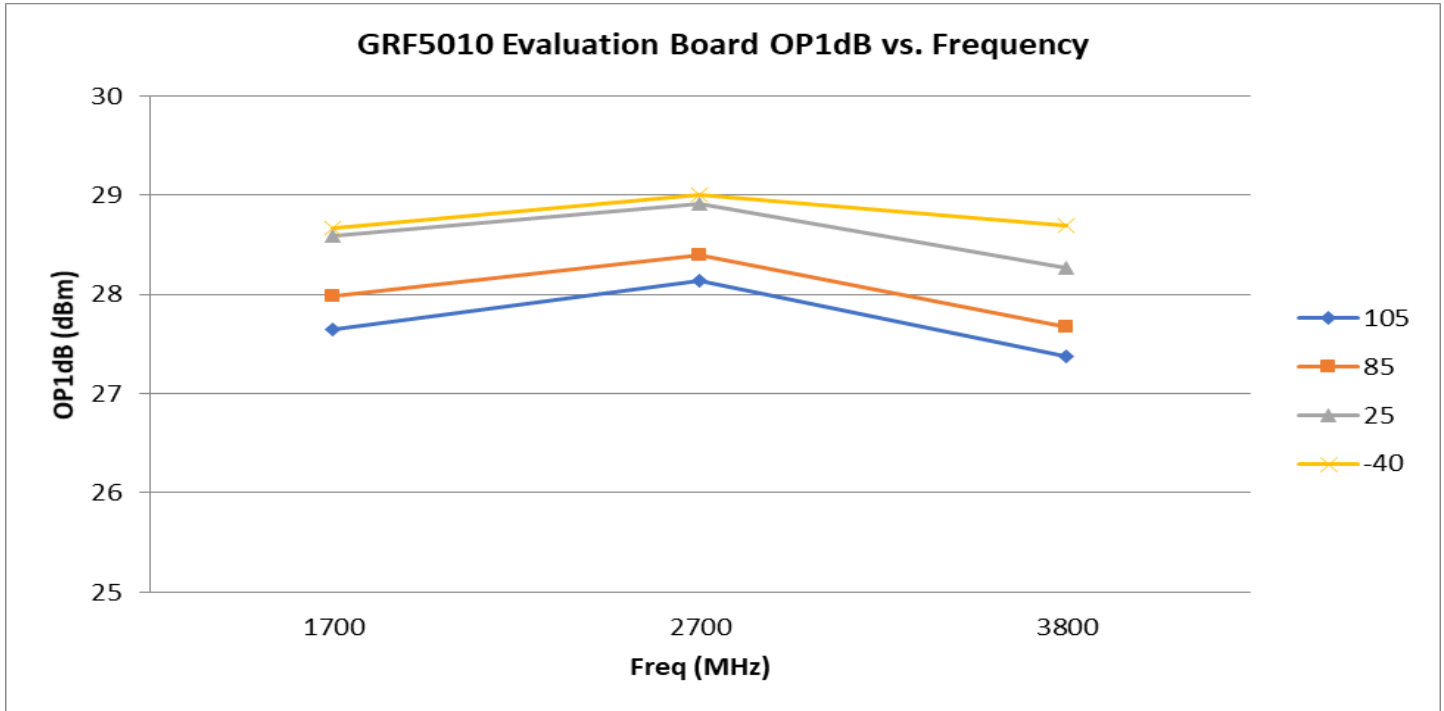



Released

GRF5010

28.5 dBm Power-LNA™

Tuning Range: 0.05 – 6.0 GHz

GRF5010 Evaluation Board Data: (1.7 to 3.8 GHz Tune)

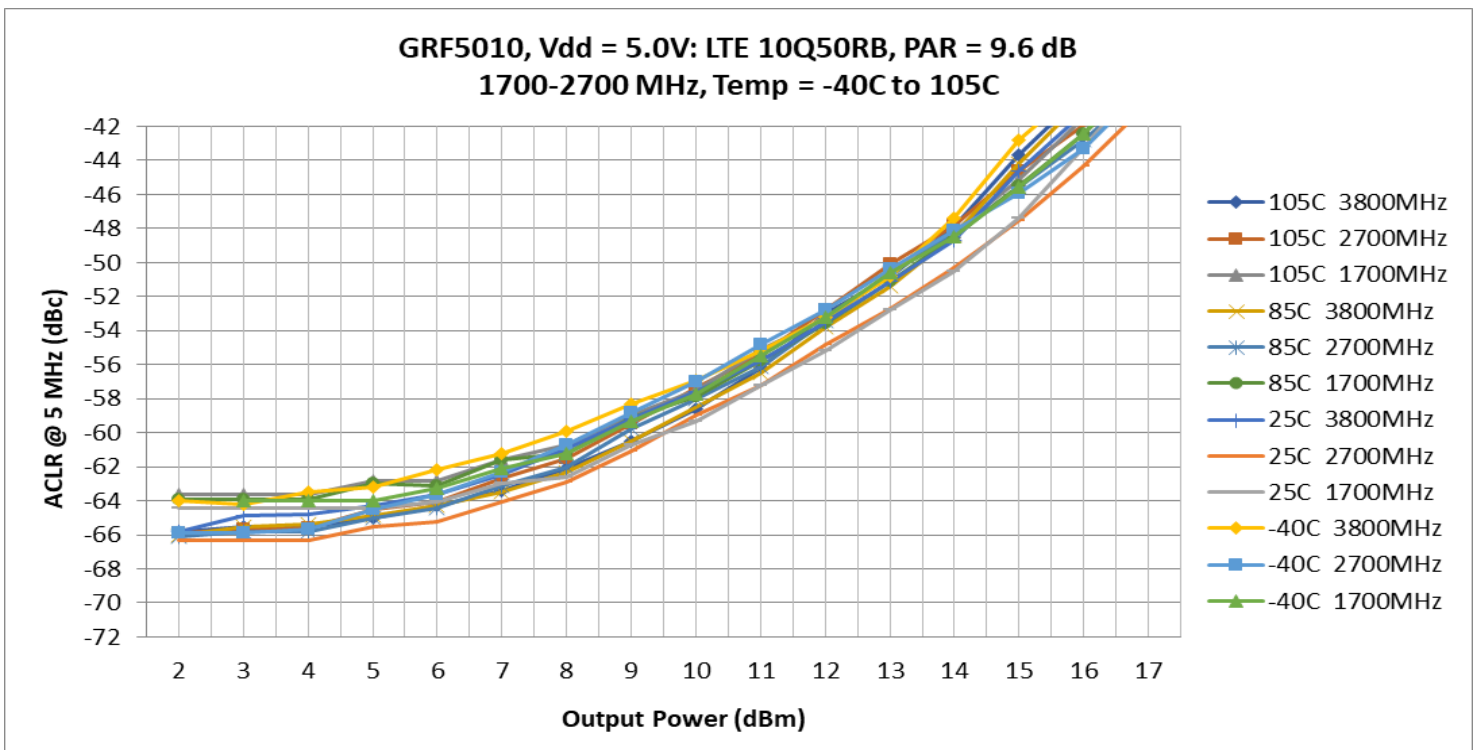
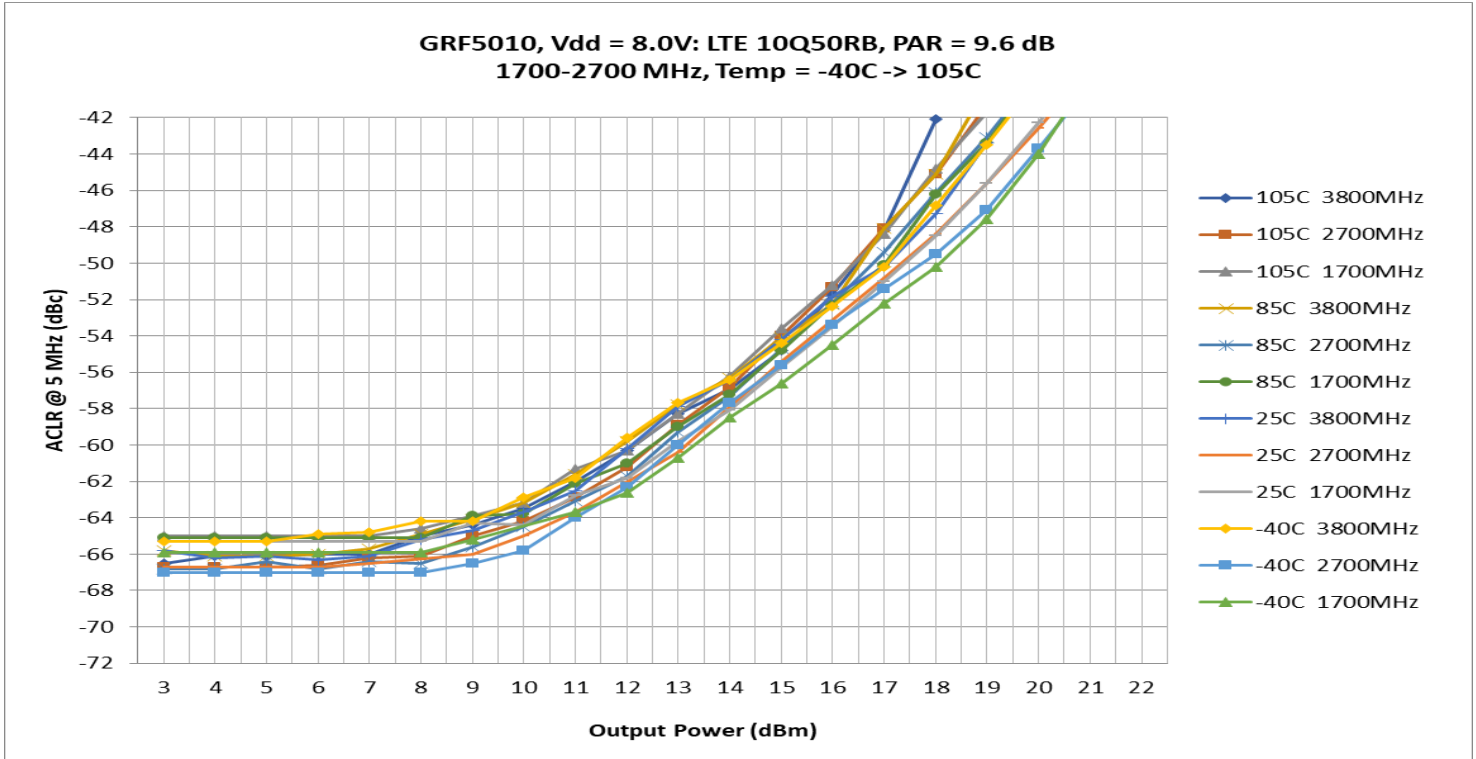



Released

GRF5010

28.5 dBm Power-LNA™

Tuning Range: 0.05 – 6.0 GHz

GRF5010 Evaluation Board Data: (1.7 to 3.8 GHz Tune)

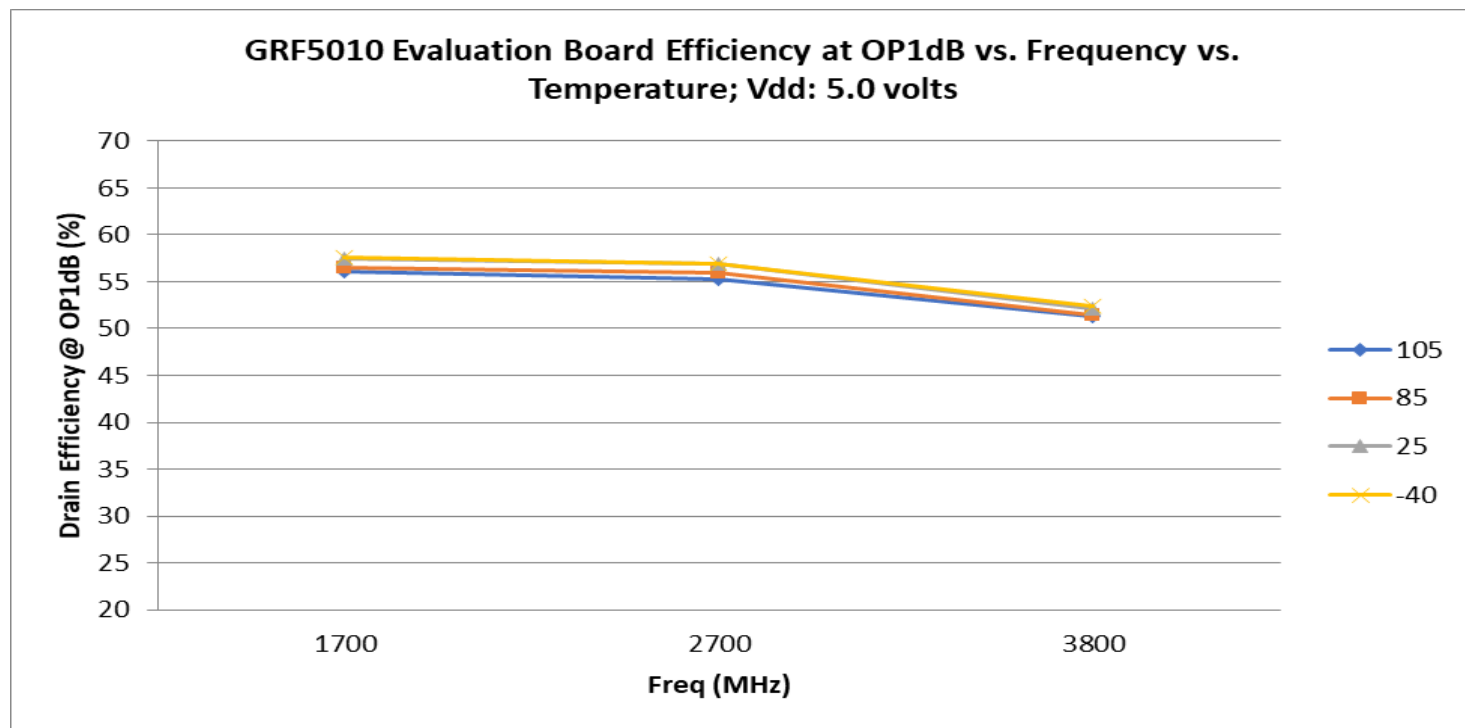
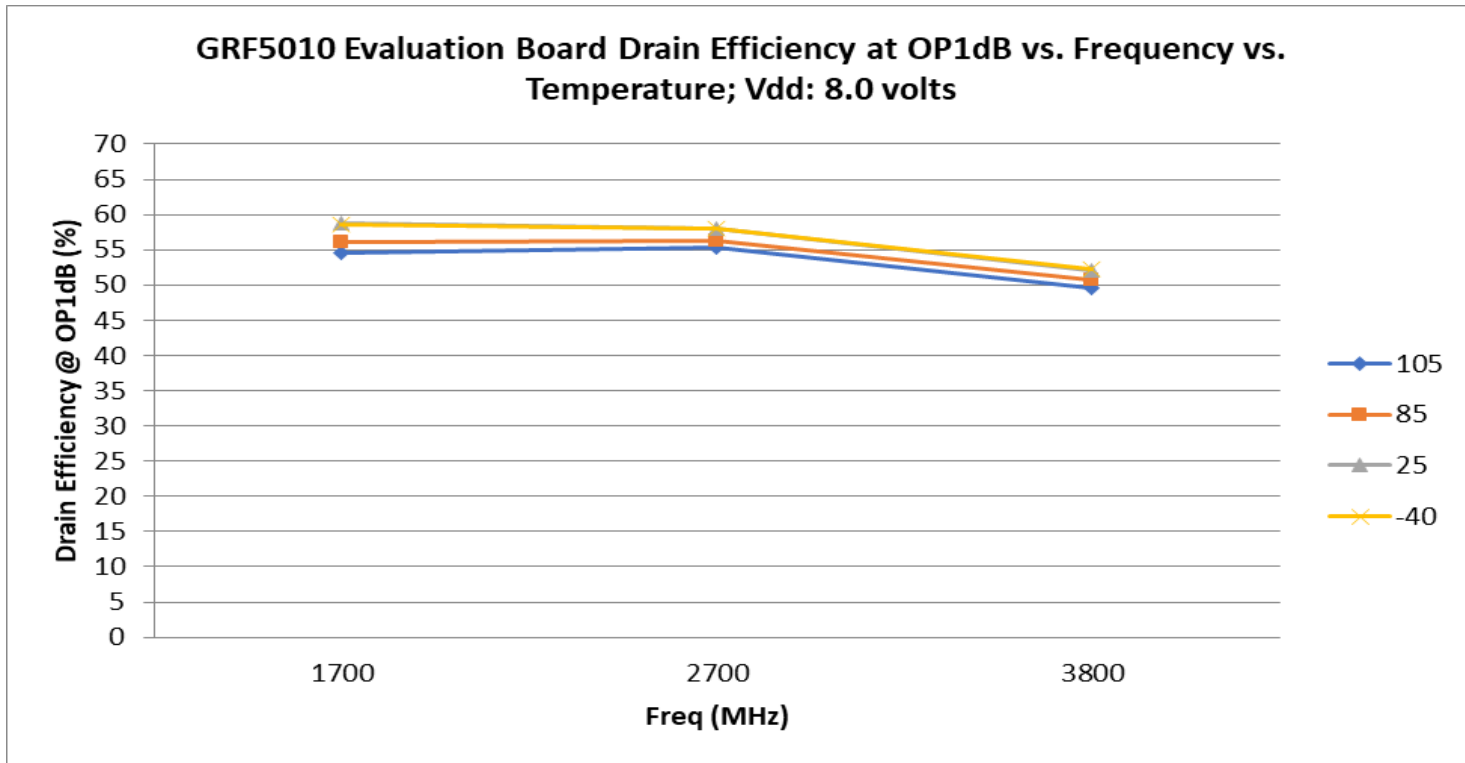



Released

GRF5010

28.5 dBm Power-LNA™
Tuning Range: 0.05 – 6.0 GHz

GRF5010 Evaluation Board S-Parms; 5V/60 mA: (1.7 to 3.8 GHz Tune)

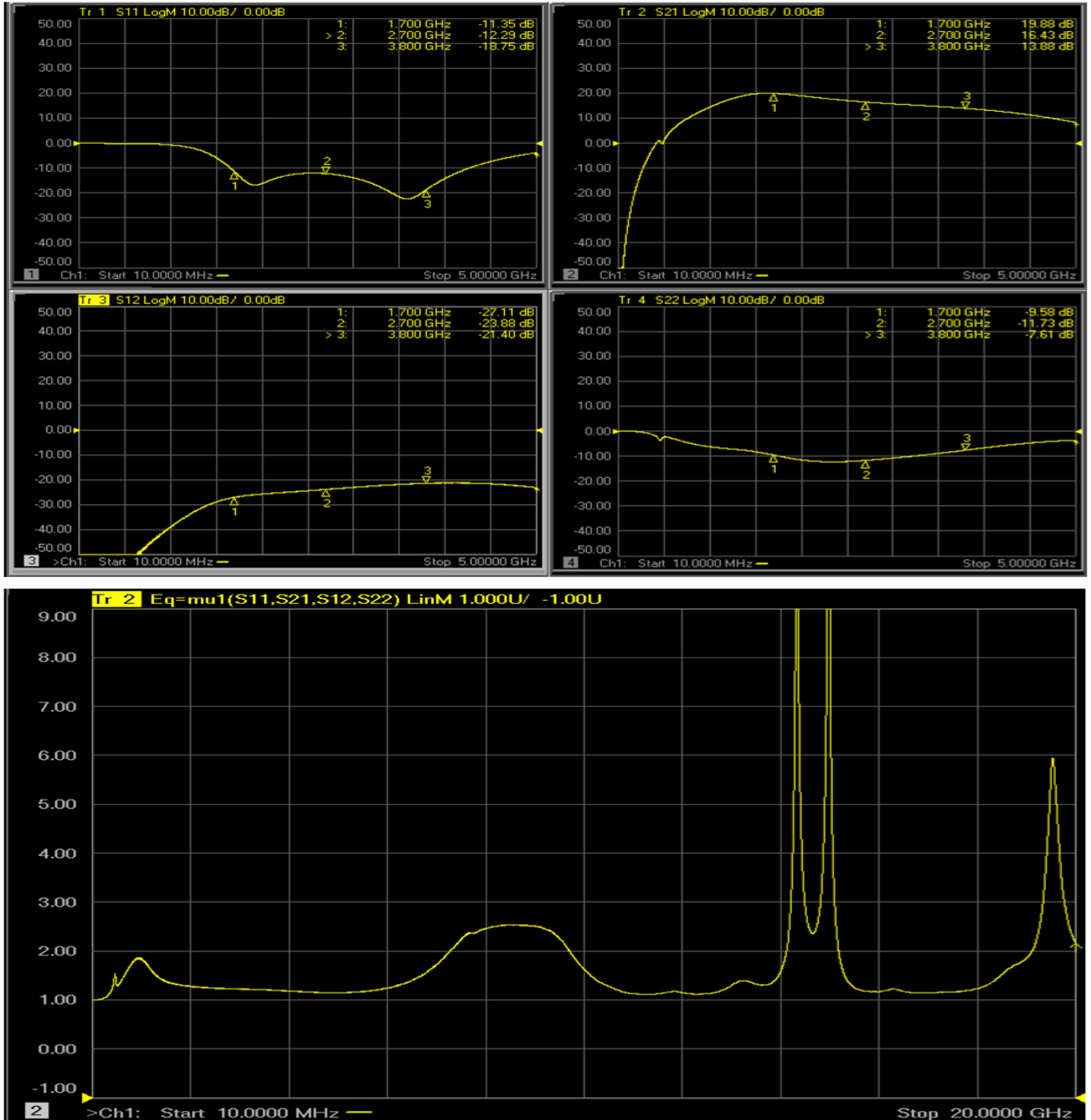

Note: Mu factor ≥ 1.0 implies unconditional stability.

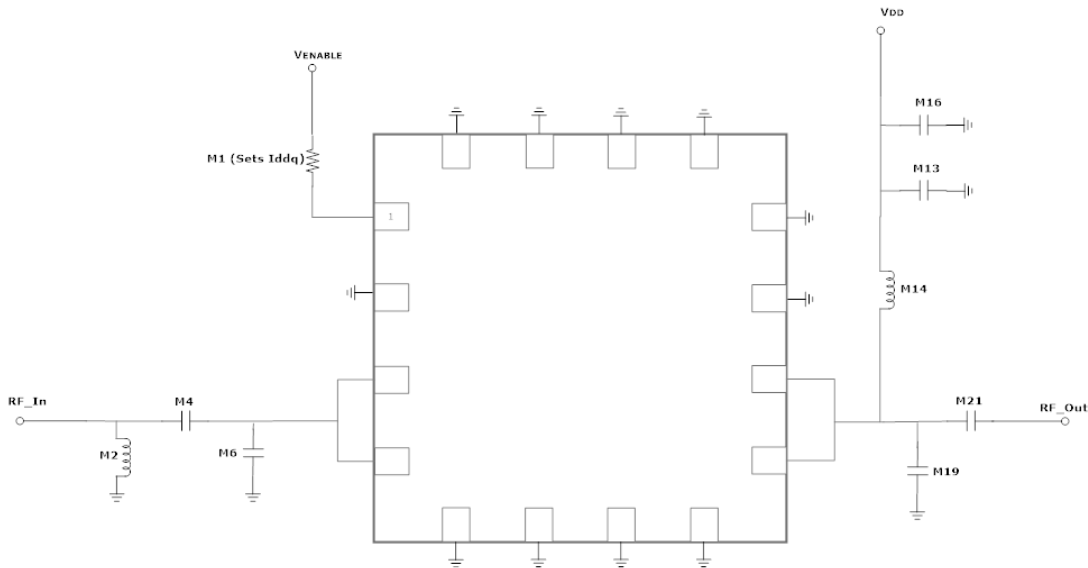

GRF5010 Application Schematic: (1.7 to 3.8 GHz)

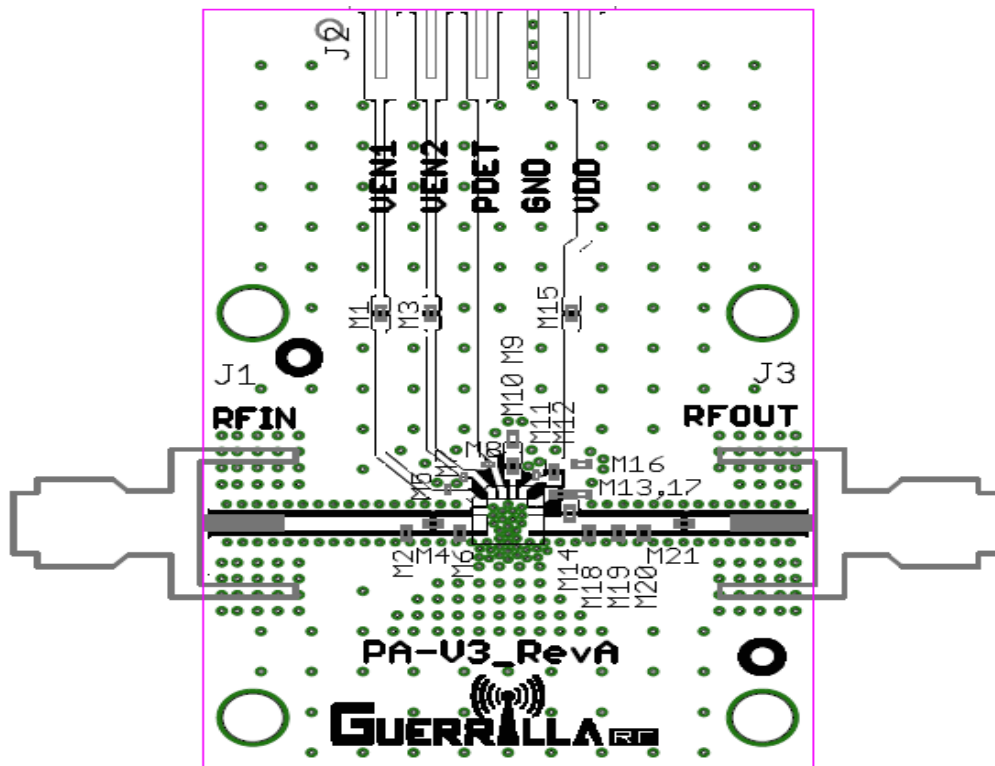

GRF50XX Evaluation Board Assembly Drawing



Released

GRF5010

28.5 dBm Power-LNA™

Tuning Range: 0.05 – 6.0 GHz

GRF5010 Evaluation Board BOM: (1.7–3.8 GHz)

Component	Type	Manufacturer	Family	Value	Package Size	Substitution
M1 (see curves)	Resistor	Various	5%	Sets Iddq	0402	ok
M2	Inductor: High Q	Coilcraft	HP	3.6 nH	0402	ok
M4	Capacitor: High Q	Murata	GJM	2.0 pF	0402	ok
M6	Capacitor: High Q	Murata	GJM	1.0 pF	0402	ok
M13	Capacitor	Murata	GRM	100 pF	0402	ok
M14	Inductor	Coilcraft	HP	10 nH	0402	ok
M16	Capacitor	Murata	GRM	0.1 uF	0402	ok
M19	DNP	—	—	—	—	—
M21	Capacitor	Murata	GJM	8.2 pF	0402	ok
Evaluation Board	PA-V3_RevA					

Note: Standard evaluation board bias: Vdd: 8.0V; Venable: 5.0V; M1:



Released

GRF5010

28.5 dBm Power-LNA™
Tuning Range: 0.05 – 6.0 GHz

GRF5010 Bias Resistor (M1) Selection Curves:

