



GS1000FL-AU SERIES

SURFACE GENERAL PURPOSE RECTIFIERS

VOLTAGE 50 to 1000 Volt **CURRENT** 1 Ampere

FEATURES

- For surface mounted applications in order to optimize board space
- Low profile package
- Ideal for automated placement
- High temperature soldering : 260°C /10 seconds at terminals
- Glass passivated chip junction
- AEC-Q101 qualified
- Lead free in compliance with EU RoHS 2.0
- Green molding compound as per IEC 61249 standard

MECHANICAL DATA

- Case: SOD-123FL, Molded plastic over passivated junction
- Terminals: Solderable per MIL-STD-750, Method 2026
- Approx. Weight: 0.0006 ounces, 0.0173 grams
- Standard Packaging: 8mm tape (EIA-481)
- Polarity: Color band denotes cathode end

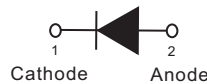

SOD-123FL Unit : inch(mm)

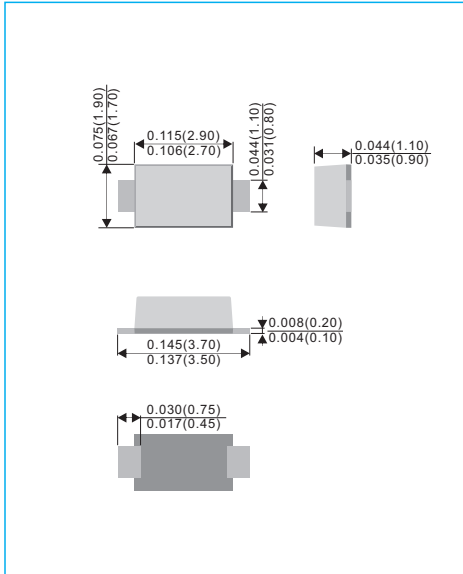

MAXIMUM RATINGS AND ELECTRICAL CHARACTERISTICS

Ratings at 25°C ambient temperature unless otherwise specified.

PARAMETER	SYMBOL	GS1000FL-AU	GS1001FL-AU	GS1002FL-AU	GS1004FL-AU	GS1006FL-AU	GS1008FL-AU	GS1010FL-AU	UNITS
Marking Code		1A	1B	1D	1G	1J	1K	1M	
Maximum Recurrent Peak Reverse Voltage	V_{RRM}	50	100	200	400	600	800	1000	V
Maximum RMS Voltage	V_{RMS}	35	70	140	280	420	640	700	V
Maximum DC Blocking Voltage	V_{DC}	50	100	200	400	600	800	1000	V
Maximum Average Forward Current	$I_{F(AV)}$	1							A
Peak One Cycle Surge Forward Current (non-repetitive)	I_{FSM}	30 (60Hz)							A
Maximum Forward Voltage at 1A (Note 1)	V_F	1.1							V
Maximum DC Reverse Current at Rated DC Blocking Voltage <small>$T_A=25^{\circ}C$ $T_A=125^{\circ}C$</small>	I_R	1 50							μA
Typical Junction Capacitance at 4V, MHz	C_J	4							pF

ELECTRICAL CHARACTERISTICS

Ratings at 25°C ambient temperature unless otherwise specified.

PARAMETER	SYMBOL	GS1000FL-AU	GS1001FL-AU	GS1002FL-AU	GS1004FL-AU	GS1006FL-AU	GS1008FL-AU	GS1010FL-AU	UNITS
Typical Thermal Resistance (Note 2)	$R_{\theta JA}$	65							°C / W
Operating and Storage Temperature Range	T_J, T_{STG}	-50 TO +150							°C

NOTES: 1.Pulse test : 300us pulse width, 1% duty cycle.
2.Soldering land: 6mm x 6mm



GS1000FL-AU SERIES

RATING AND CHARACTERISTIC CURVES

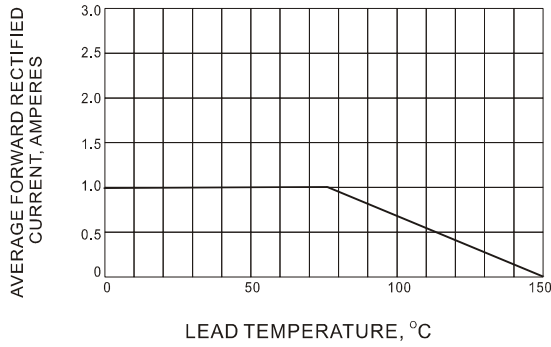

Fig.1 FORWARD CURRENT DERATING CURVE

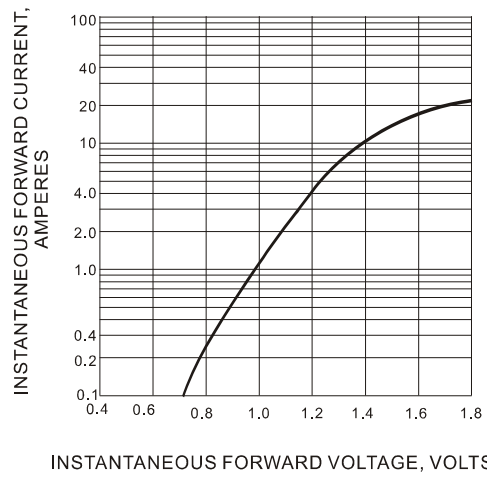

Fig.2-TYPICAL INSTANTANEOUS FORWARD CHARACTERISTICS

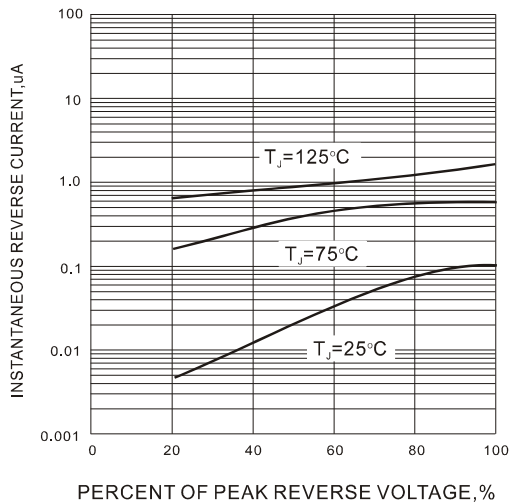

Fig.3 TYPICAL REVERSE CHARACTERISTICS

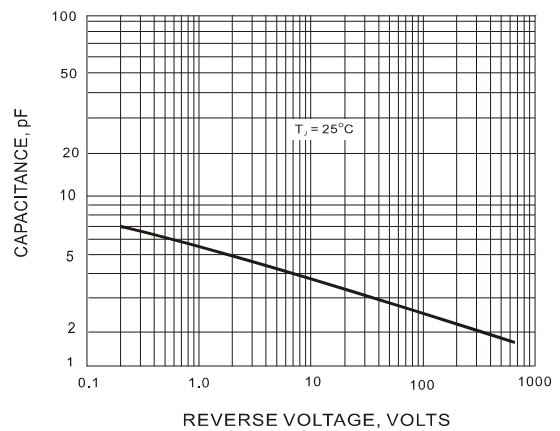

Fig.4 TYPICAL JUNCTION CAPACITANCE

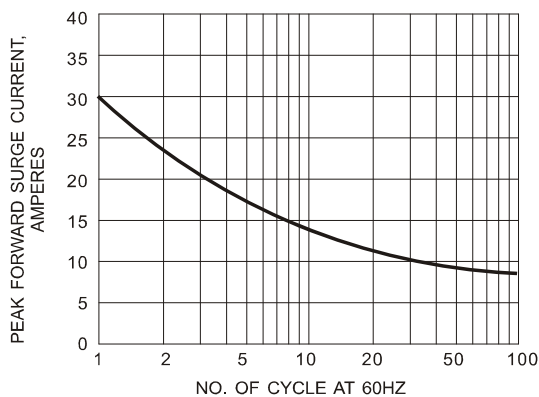

Fig.5- MAXIMUM NON - REPETITIVE SURGE CURRENT



GS1000FL-AU SERIES

MOUNTING PAD LAYOUT

SOD-123FL Unit : inch(mm)

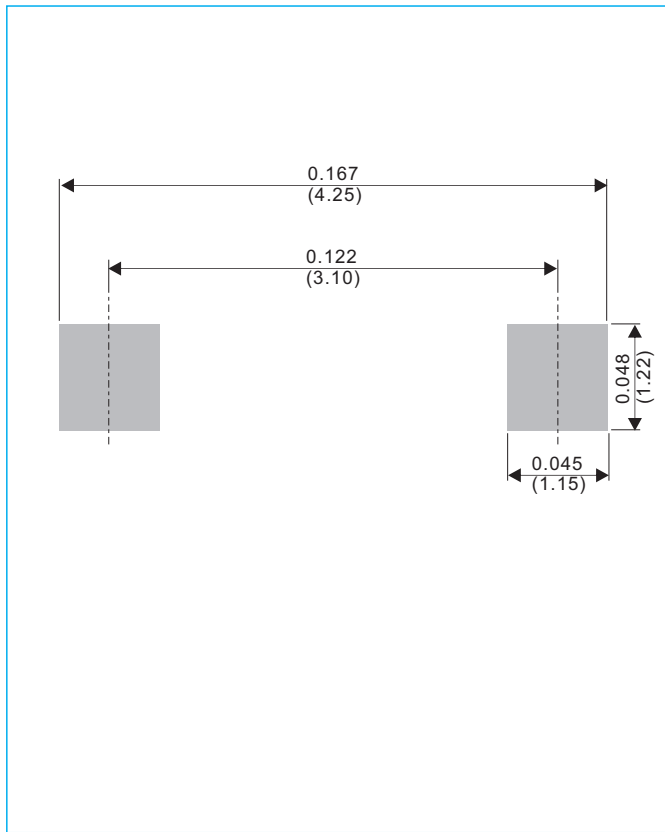

ORDER INFORMATION

- Packing information
 - T/R - 10K per 13" plastic Reel
 - T/R - 3K per 7" plastic Reel



GS1000FL-AU SERIES

Part No._packing code_Version

GS1000FL-AU_R1_000A1

GS1000FL-AU_R2_000A1

For example :

RB500V-40_R2_00001

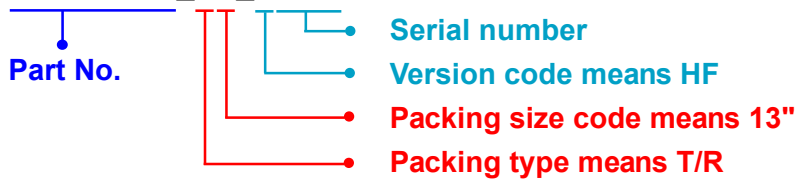

Packing Code XX				Version Code XXXXX		
Packing type	1 st Code	Packing size code	2 nd Code	HF or RoHS	1 st Code	2 nd ~5 th Code
Tape and Ammunition Box (T/B)	A	N/A	0	HF	0	serial number
Tape and Reel (T/R)	R	7"	1	RoHS	1	serial number
Bulk Packing (B/P)	B	13"	2			
Tube Packing (T/P)	T	26mm	X			
Tape and Reel (Right Oriented) (TRR)	S	52mm	Y			
Tape and Reel (Left Oriented) (TRL)	L	PANASERT T/B CATHODE UP (PBCU)	U			
FORMING	F	PANASERT T/B CATHODE DOWN (PBCD)	D			