



GS1674 Adaptive Cable Equalizer

The GS1674 is a high-speed BiCMOS integrated circuit designed to equalize and restore signals received over 75Ω coaxial cable. The device is optimized for performance at 270Mb/s and 1.485Gb/s, and features DC restoration to compensate for the DC content of SMPTE pathological test patterns.

The Carrier Detect output pin (\overline{CD}) indicates whether a valid input signal has been detected. It can be connected directly to the MUTE pin to mute the output on loss of carrier. The sensitivity of the carrier detect can be easily programmed to allow the GS1674 to distinguish between low-amplitude SDI signals and noise at the input of the device. The equalizing and DC restore stages are disengaged when the BYPASS pin is HIGH. No equalization occurs in Bypass mode.

The GS1674 is footprint and drop-in compatible with existing GS1574A and LMH0044 designs, with no additional application changes required.

Key Features

- Replaces the LMH0044
- SMPTE 292M, SMPTE 344M and SMPTE 259M compliant
- Automatic cable equalization
- Performance optimized for 270Mb/s and 1.485Gb/s. Typical equalized length of Belden 1694A cable:
 - ♦ 220m at 1.485Gb/s
 - ♦ 400m at 270Mb/s
- Supports DVB-ASI at 270Mb/s
- Manual bypass (useful for low data rates with slow rise/fall times)
- Programmable carrier detect with squelch threshold adjustment
- Standard EIA/JEDEC logic control and status signal levels
- Single 3.3V power supply operation
- 195mW power consumption (typical)
- Wide temperature range of -40°C to +85°C
- Small footprint QFN package (4mm x 4mm)
- Drop-in compatible with the GS1574A. Forward compatible with Gennum's 3G EQ products.
- Pb-free and RoHS compliant

Typical Application Circuit

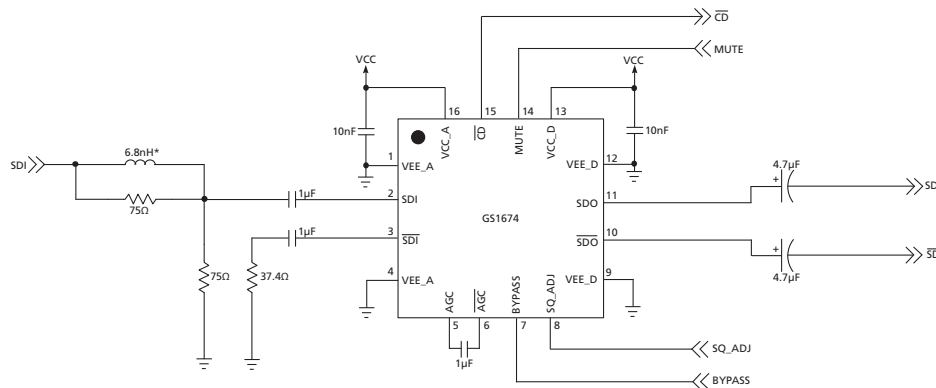

NOTE: All resistors in Ohms, capacitors in Farads, and inductors in Henrys, unless otherwise noted.
* Value dependent on layout

Contents

Key Features	1
Typical Application Circuit.....	1
1. Pin Out.....	3
1.1 GS1674 Pin Assignment	3
1.2 GS1674 Pin Descriptions	3
2. Electrical Characteristics	5
2.1 Absolute Maximum Ratings	5
2.2 DC Electrical Characteristics	5
2.3 AC Electrical Characteristics	6
2.4 Typical Performance Curves	7
3. Detailed Description.....	8
3.1 Serial Data Inputs	8
3.2 Cable Equalization	8
3.3 Programmable Squelch Adjust (SQ_ADJ)	9
3.4 Mute and Carrier Detect	9
3.5 Output Rise/Fall Times	10
4. Application Information	11
4.1 High-Gain Adaptive Cable Equalizers	11
4.2 PCB Layout	11
4.3 Typical Application Circuit	11
5. Input/Output Circuits	12
6. Package & Ordering Information	13
6.1 Package Dimensions	13
6.2 Packaging Data	13
6.3 Recommended PCB Footprint	14
6.4 Marking Diagram	14
6.5 Solder Reflow Profiles	15
6.6 Ordering Information	15
Revision History	16

1. Pin Out

1.1 GS1674 Pin Assignment

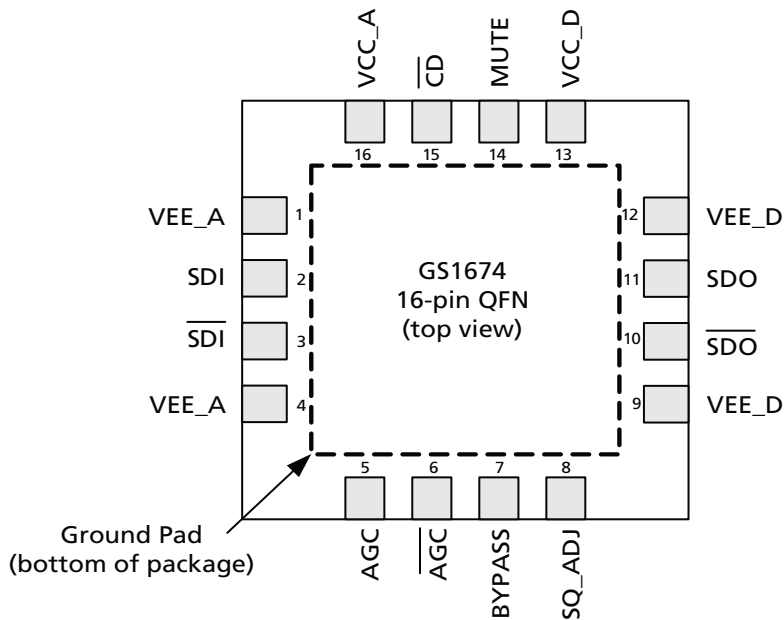

Figure 1-1: GS1674 Pin Out

1.2 GS1674 Pin Descriptions

Table 1-1: GS1674 Pin Descriptions

Pin Number	Name	Timing	Type	Description
1, 4	VEE_A	Analog	Power	Most negative power supply for analog circuitry. Connect to GND.
2, 3	SDI, $\overline{\text{SDI}}$	Analog	Input	Serial digital differential input.
5, 6	AGC, $\overline{\text{AGC}}$	Analog	–	External AGC capacitor. Connect pin 5 and pin 6 together as shown in the GS1674 Typical Application Circuit on page 11 .
7	BYPASS	Not Synchronous	Input	Forces the Equalizing and DC RESTORE stages into bypass mode when HIGH. No equalization occurs in this mode. (Internal pull-down).
8	SQ_ADJ	Analog	Input	Squelch Adjust. Adjusts the approximate amount of cable equalized before $\overline{\text{CD}}$ goes low. See Section 3.3 and Section 3.4 . (Internal pull-down).
9, 12	VEE_D	Analog	Power	Most negative power supply for the digital circuitry and output buffer. Connect to GND.
10, 11	$\overline{\text{SDO}}$, SDO	Analog	Output	Equalized serial digital differential output.

Table 1-1: GS1674 Pin Descriptions (Continued)

Pin Number	Name	Timing	Type	Description
13	VCC_D	Analog	Power	Most positive power supply for the digital I/O pins of the device. Connect to +3.3V DC.
14	MUTE	Not Synchronous	Input	CONTROL SIGNAL INPUT levels are LVCMOS/LVTTL compatible. (3.3V Tolerant) Controls output behaviour on SDO and \overline{SDO} . (Internal pull-down). See Section 3.4 .
15	\overline{CD}	Not Synchronous	Output	STATUS SIGNAL OUTPUT Signal levels are LVCMOS/LVTTL compatible. Indicates the presence of an input signal. See Section 3.4 .
16	VCC_A	Analog	Power	Most positive power supply for the analog circuitry of the device. Connect to +3.3V DC.
–	Center Pad	–	Power	Internally bonded to VEE_A.

NOTE:

For 3G migration, pins 4 and 9 are input select pins.

2. Electrical Characteristics

2.1 Absolute Maximum Ratings

Parameter	Value
Supply Voltage	-0.5V to +3.6V DC
Input ESD Voltage (HBM)	5kV
Storage Temperature Range	-50°C < T _s < 125°C
Input Voltage Range (any input)	-0.3 to (V _{CC} +0.3)V
Operating Temperature Range	-20°C to +85°C
Functional Temperature Range	-40°C to +85°C
Solder Reflow Temperature	260°C

2.2 DC Electrical Characteristics

Table 2-1: DC Electrical Characteristics

V_{CC} = 3.3V ±5%, T_A = -20°C to +85°C, unless otherwise shown

Parameter	Symbol	Conditions	Min	Typ	Max	Units	Notes
Supply Voltage	V _{CC}	–	3.135	3.3	3.465	V	–
Power Consumption	P _D	T _A = 25°C	–	195	250	mW	–
Supply Current	I _s	T _A = 25°C	–	59	–	mA	–
Output Common Mode Voltage	V _{CMOUT}	T _A = 25°C	–	V _{CC} - (ΔV _{SDO})/2	–	V	–
Input Common Mode Voltage	V _{CMIN}	T _A = 25°C	–	1.8	–	V	–
SQ_ADJ DC Voltage (to mute signal)	–	0m, T _A = 25°C	–	3.2	–	V	–
SQ_ADJ Range	–	T _A = 25°C	–	0.9	–	V	–
CD̄ Output Voltage	V _{CD̄(OH)}	Carrier not present	2.4	–	–	V	–
	V _{CD̄(OL)}	Carrier present	–	–	0.4	V	–
Mute Input Voltage Required to Force Outputs to Mute	V _{Mute}	Min to Mute	2.0	–	–	V	–
Mute Input Voltage Required to Force Outputs Active	V _{Mute}	Max to Activate	–	–	0.8	V	–

2.3 AC Electrical Characteristics

Table 2-2: AC Electrical Characteristics

$V_{CC} = 3.3V \pm 5\%$, $T_A = -20^\circ C$ to $+85^\circ C$, unless otherwise shown

Parameter	Symbol	Conditions	Min	Typ	Max	Units	Notes
Serial input data rate	DR_{SDO}	–	143	–	1485	Mb/s	–
Input Voltage Swing	ΔV_{SDI}	$T_A = 25^\circ C$, differential, 270Mb/s and 1.485Gb/s	720	800	950	mV _{p-p}	1
Output Voltage Swing	ΔV_{SDO}	100 Ω load, $T_A = 25^\circ C$, differential	680	800	900	mV _{p-p}	–
Output Jitter of Various Cable Lengths and Data Rates	–	1.485Gb/s Belden 1694A: 0-220m	–	0.25	–	UI	–
	–	270Mb/s Belden 1694A: 0-400m	–	–	0.2	UI	2,
Output Rise/Fall time	–	1.485Gb/s 20% - 80%	35	65	90	ps	–
	–	270Mb/s (see Section 3.5)	–	–	–	–	–
Mismatch in rise/fall time	–	–	–	–	30	ps	–
Duty cycle distortion	–	–	–	–	30	ps	–
Overshoot	–	–	–	–	10	%	–
Input Return Loss	–	–	15	21	–	dB	–
Input Resistance	–	Single-ended	–	1.9	–	k Ω	–
Input Capacitance	–	Single-ended	–	1.3	–	pF	–
Output Resistance	–	Single-ended	–	50	–	Ω	–

NOTES:

- 0m cable length.
- All parts are production tested. In order to guarantee jitter over the full range of specification ($V_{CC} = 3.3V \pm 5\%$, $T_A = -20^\circ C$ to $+85^\circ C$, and 720-880mV launch swing from the SDI cable driver) the recommended applications circuit must be used.

2.4 Typical Performance Curves

VCC=3.3V, room temperature, 800mV launch swing

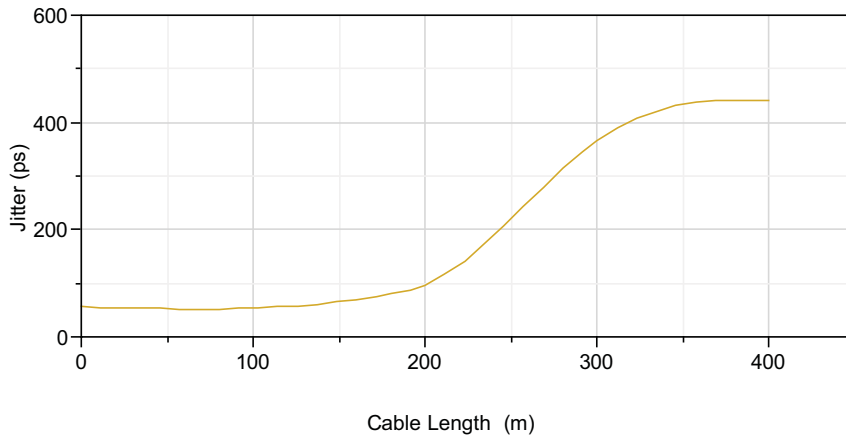

Figure 2-1: Jitter vs. Cable Length (270 Mb/s)

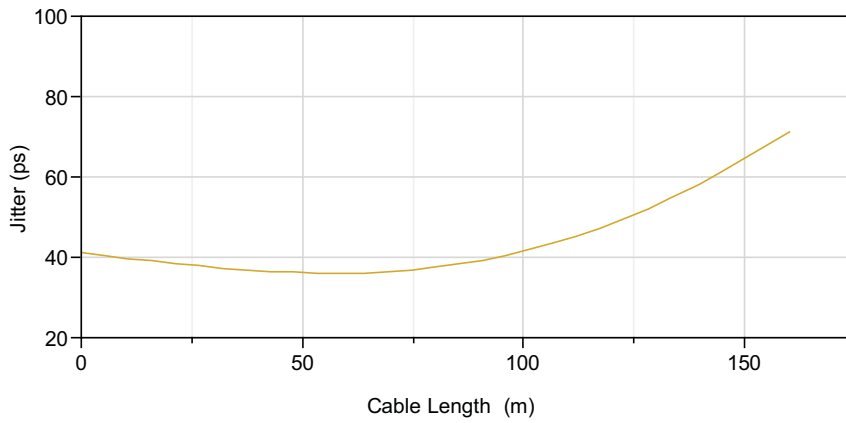

Figure 2-2: Jitter vs. Cable Length (1485 Mb/s)

3. Detailed Description

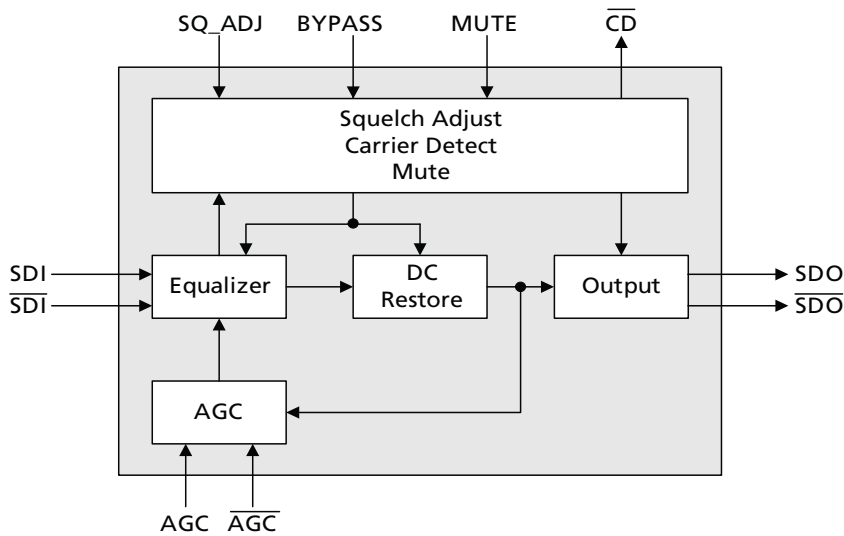

Figure 3-1: GS1674 Functional Block Diagram

The GS1674 is a high-speed BiCMOS IC designed to equalize serial digital signals.

The GS1674 can equalize HD and SD serial digital signals, and will typically equalize 200m at 1.485Gb/s and 400m at 270Mb/s. The GS1674 is powered from a single +3.3V power supply, and consumes approximately 195mW of power.

3.1 Serial Data Inputs

The Serial Data Input signals can be connected to the input pins (SDI/ \overline{SDI}) in either a differential or single-ended configuration. AC-coupling of the inputs is recommended, as the SDI and \overline{SDI} inputs are internally biased at approximately 1.8V.

3.2 Cable Equalization

The input signal passes through a variable gain equalizing stage, whose frequency response closely matches the inverse of the cable loss characteristic. In addition, the variation of the frequency response with control voltage imitates the variation of the inverse cable loss characteristic with cable length.

The edge energy of the equalized signal is monitored by a detector circuit which produces an error signal corresponding to the difference between the desired edge energy and the actual edge energy. This error signal is integrated by both an internal and an external AGC filter capacitor providing a steady control voltage for the gain stage. As the frequency response of the gain stage is automatically varied by the application of negative feedback, the edge energy of the equalized signal is kept at a constant level which is representative of the original edge energy at the transmitter. The equalized signal is also DC-restored, effectively restoring the logic threshold of the equalized signal to its correct level independent of shifts due to AC-coupling.

3.3 Programmable Squelch Adjust (SQ_ADJ)

The GS1674 incorporates a programmable Squelch Adjust (SQ_ADJ) threshold.

This feature can be useful in applications where there are multiple input channels using the GS1674 and the maximum gain can be limited to avoid crosstalk.

The SQ_ADJ pin acts to change the threshold of the Carrier Detect (\overline{CD}) pin, through voltage level variances. When the input signal drops below a certain threshold, the \overline{CD} pin will be driven high, indicating that there is not a valid input signal. In order to enable automatic muting of the output of the GS1674, the \overline{CD} pin should be connected directly to the MUTE pin. In applications where programmable squelch adjust is not required, the SQ_ADJ pin may be left unconnected. Figure 3-2 shows the relationship between the SQ_ADJ voltage and cable length at which \overline{CD} will assert or deassert.

This feature has been designed for use in applications such as routers, where signal crosstalk and circuit noise cause the Equalizer to output erroneous data when no input signal is present. The use of a Carrier Detect function with a fixed internal reference does not solve this problem, since the signal to noise ratio on the circuit board could be significantly less than the default signal detection level set by the on chip reference.

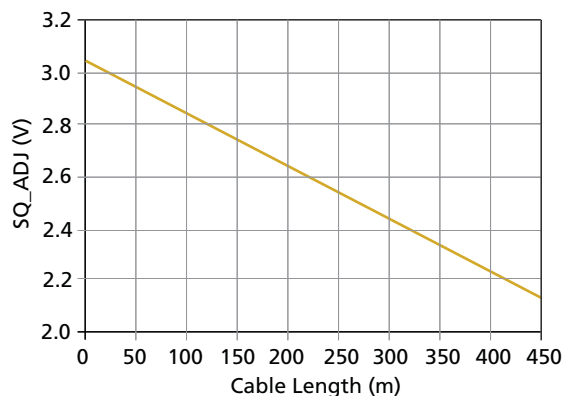

Figure 3-2: SQ_ADJ vs. Cable Length (VCC=3.3V, room temperature, 800mV launch swing)

3.4 Mute and Carrier Detect

The GS1674 includes a MUTE input pin that allows the application interface to mute the Serial Digital Output at any time. Set the MUTE pin HIGH to mute SDO and \overline{SDO} . In this case, the outputs will mute regardless of the setting of the BYPASS pin.

A Carrier Detect output pin (\overline{CD}) indicates the presence of a valid signal at the input of the GS1674. When \overline{CD} is LOW, the device has detected a valid input on SDI and \overline{SDI} . When \overline{CD} is HIGH, the device has not detected a valid input. The \overline{CD} output pin may be connected directly to the MUTE input pin to enable automatic muting of the GS1674 when no valid input signal has been detected.

NOTE 1: \overline{CD} will only detect loss of carrier for data rates greater than 19Mb/s.

NOTE 2: If the maximum cable length is exceeded (set by the SQ_ADJ pin) and the device is not in Bypass mode, the \overline{CD} pin will not be driven low, even if a carrier is present.

Table 3-1: Mute Input Table

Mute	Function
0	SDO and \overline{SDO} operate normally
1	SDO and \overline{SDO} are forced to a steady state (either HIGH or LOW)

Table 3-2: \overline{CD} Output Table

\overline{CD}	Input Status
0	Valid Input on SDI, \overline{SDI} pins
1	Input is not valid

3.5 Output Rise/Fall Times

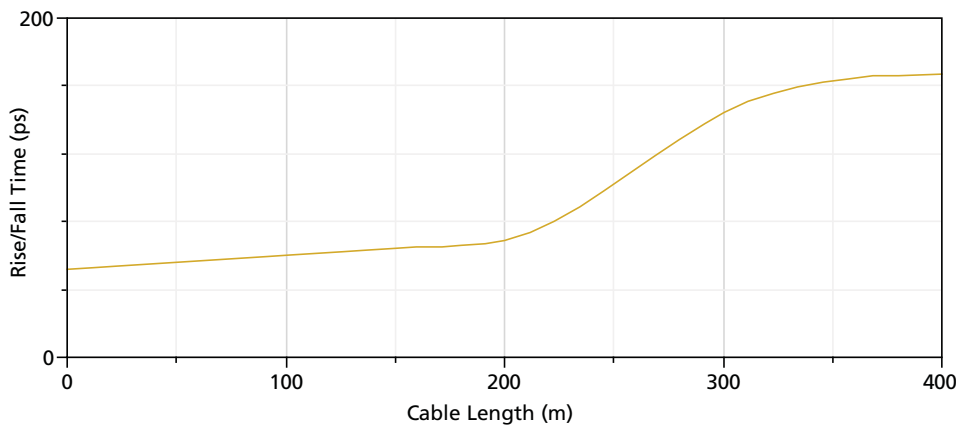

Figure 3-3: Typical Rise/Fall Time for 270Mb/s Data Rate (VCC=3.3V, room temperature, 800mV launch swing)

The GS1674 was designed to limit bandwidth as cable length is increased. During normal HD (1.485Gb/s), and SD (270Mb/s) operation, the impact of this is minimal on rise and fall time over the operating range from 0-200m. Above 200m, this bandwidth limitation becomes more significant, and reduction in rise and fall time is observed. This means that for SD (270Mb/s) operation at cable lengths greater than 200m, rise and fall times are slow as shown in [Figure 3-3](#) above. This is beneficial because at 270Mb/s, one unit interval is equal to 3.7ns, so rise and fall times less than 100ps are not required, and slower rise and fall times actually help to reduce EMI.

4. Application Information

4.1 High-Gain Adaptive Cable Equalizers

The GS1674 is Gennum's latest HD-optimized adaptive cable equalizer. In order to continue to extend the cable length that an equalizer will remain operational over, it is necessary to have high-gain in the equalizer.

A video cable equalizer must provide wide band gain over a range of frequencies in order to accommodate the range of data rates and signal patterns that are present in a SMPTE compliant serial video stream.

The GS1674 has an increase in gain over the GS1574A at critical HD frequencies, and because of this, the GS1674 may be sensitive to signals at the input that the GS1574A will not be sensitive to.

Small levels of signal or noise present at the input pins of the Equalizer may cause chatter at the output. In order to prevent this from happening, particular attention must be paid to board layout.

4.2 PCB Layout

Special attention must be paid to component layout when designing Serial Digital Interfaces for HDTV. An FR-4 dielectric can be used, however, controlled impedance transmission lines are required for PCB traces longer than approximately 1cm. Note the following PCB artwork features used to optimize performance:

- The PCB ground plane is removed under the GS1674 input components to minimize parasitic capacitance
- The PCB ground plane is removed under the GS1674 output components to minimize parasitic capacitance
- High-speed traces are curved to minimize impedance changes

4.3 Typical Application Circuit

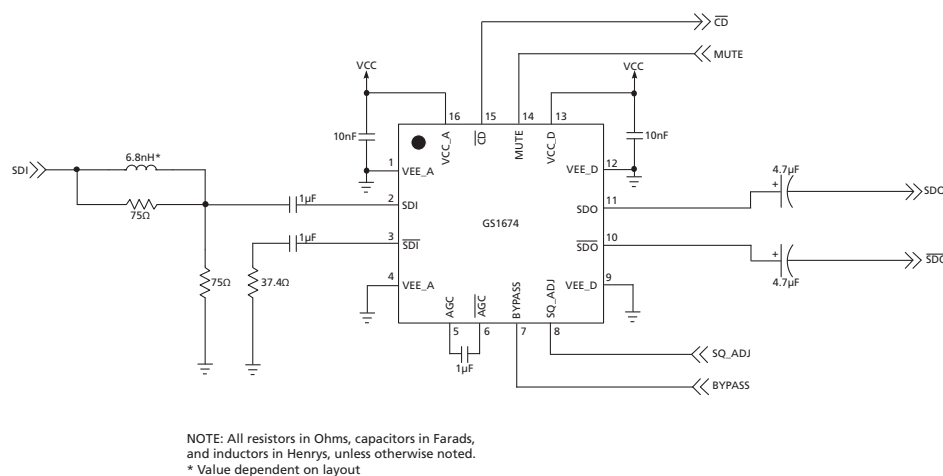

Figure 4-1: GS1674 Typical Application Circuit

5. Input/Output Circuits

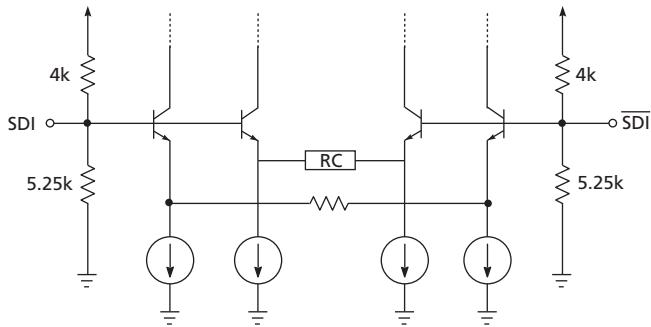

Figure 5-1: Input Equivalent Circuit

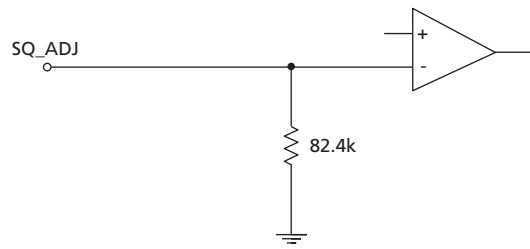

Figure 5-2: SQ_ADJ Equivalent Circuit

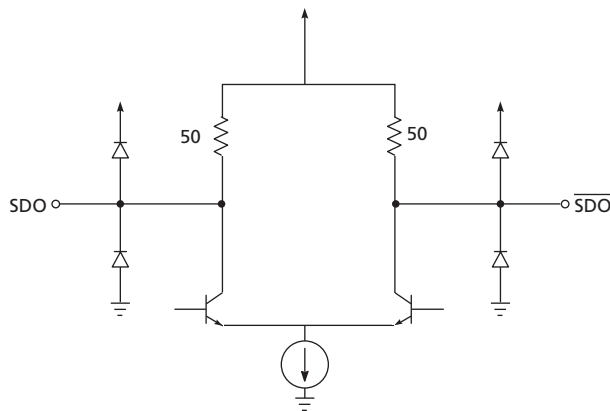

Figure 5-3: Output Circuit

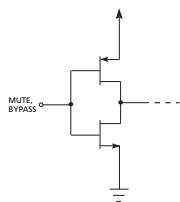

Figure 5-4: MUTE and BYPASS Circuits

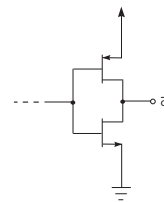
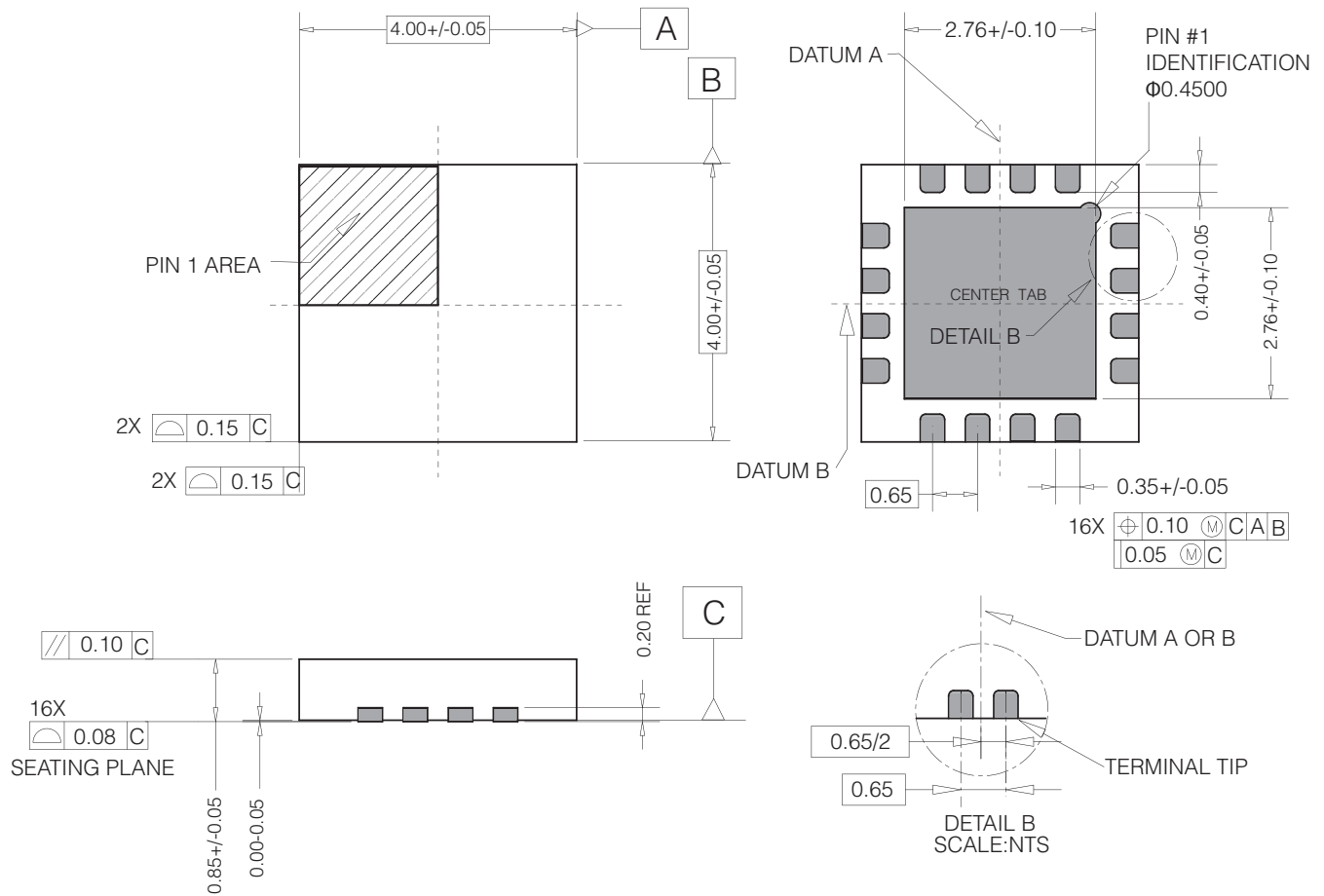

Figure 5-5: \overline{CD} Circuit

6. Package & Ordering Information

6.1 Package Dimensions



6.2 Packaging Data

Parameter	Value
Package Type	4mm x 4mm 16-pin QFN
Package Drawing Reference	JEDEC M0220
Moisture Sensitivity Level	3
Junction to Case Thermal Resistance, θ_{j-c}	31.0°C/W
Junction to Air Thermal Resistance, θ_{j-a} (at zero airflow)	43.8°C/W
Psi, ψ	11.0°C/W
Pb-free and RoHS compliant	Yes

6.3 Recommended PCB Footprint

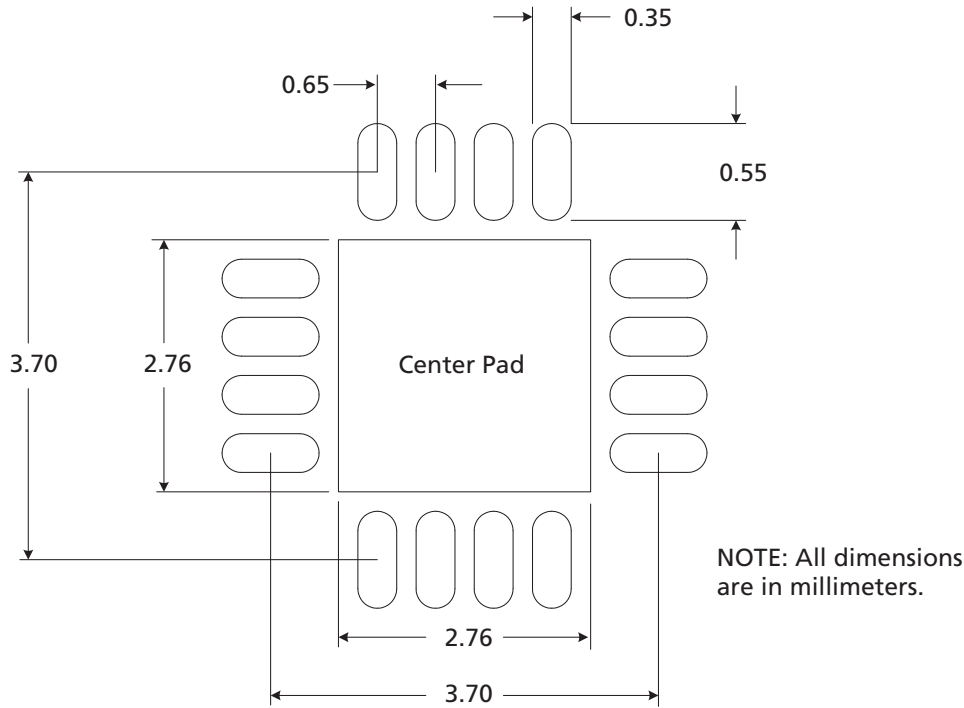

The center pad should be connected to the most negative power supply plane for analog circuitry in the device (VEE_A) by a minimum of 5 vias.

NOTE: Suggested dimensions only. Final dimensions should conform to customer design rules and process optimizations.

6.4 Marking Diagram

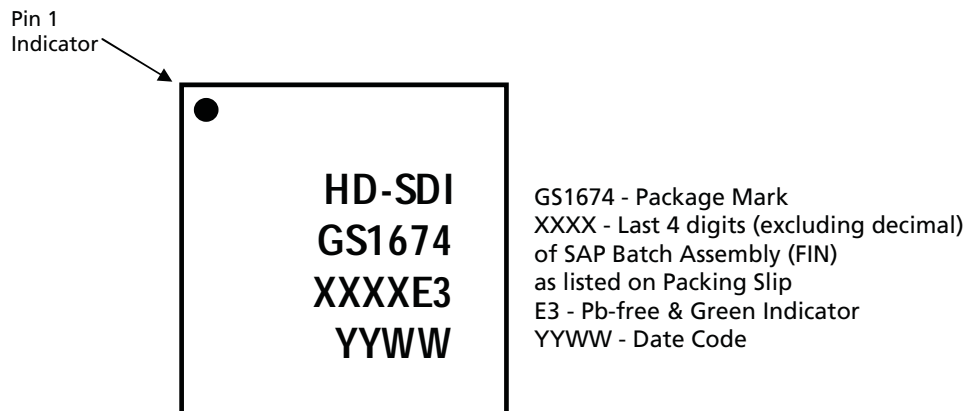

6.5 Solder Reflow Profiles

The GS1674 is available in a Pb-free package. It is recommended that the Pb-free package be soldered with Pb-free paste using the reflow profile shown in Figure 6-1.

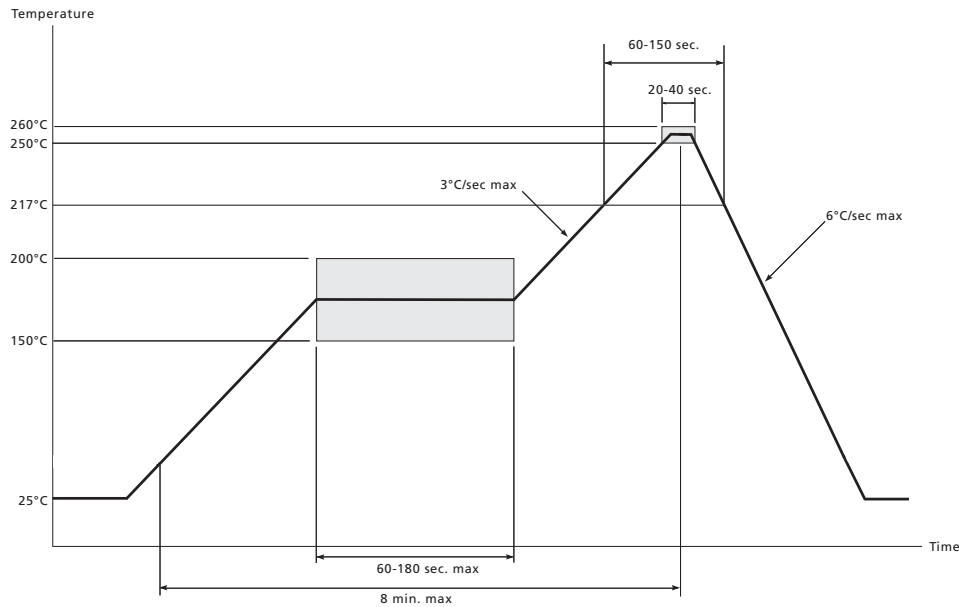

Figure 6-1: Maximum Pb-free Solder Reflow Profile

6.6 Ordering Information

	Part Number	Package	Temperature Range
GS1674	GS1674-INE3	16-pin QFN	-40°C to 85°C
GS1674	GS1674-INTE3	16-pin QFN Tape & Reel (250pcs)	-40°C to 85°C

Revision History

Version	ECR	PCN	Date	Changes and/or Modifications
2	158586	54547	September 2012	Change in Input ESD Voltage (HBM) parameter in 2.1 Absolute Maximum Ratings
1	154866	–	September 2010	Increased cable length to 220m at 1.485Gb/s.
0	154128	–	May 2010	Converted to Data Sheet. Changed pin 4 and pin 9 names in Pin Out and Application Information .
A	153462	–	March 2010	New document.