

# GS61004B-EVBCD

## 100V GaN E-HEMT Full Bridge Evaluation Board.

Technical Manual



Visit [www.gansystems.com](http://www.gansystems.com) for the latest version of this Technical Manual.



**DANGER!**

Electrical Shock Hazard - Hazardous high voltage may be present on the board during the test and even brief contact during operation may result in severe injury or death. Follow all locally approved safety procedures when working around high voltage.

Never leave the board operating unattended. After it is de-energized, always wait until all capacitors are discharged before touching the board.

**This board should be handled by qualified personnel ONLY.**



PCB surface can become hot. Contact may cause burns. Do not touch!

**CAUTION:**

This product contains parts that are susceptible to damage by electrostatic discharge (ESD) or exposure to voltages in excess of the specified voltage. Always follow ESD prevention procedures when handling the product. Avoid applying excessive voltages to the power supply terminals or signal inputs or outputs

## Introduction

The GS61004B-EVBCD evaluation board allows the user to evaluate our GaN Systems’ GS61004B Enhancement mode-High Electron Mobility Transistors (E-HEMTs) with the Peregrine PE29102 gate driver in a full-bridge configuration. The PE29102 integrated high-speed driver is designated to control the gates of our E-HEMTs. The outputs of the PE29102 are capable of providing switching transition speeds in the sub nano-second range for hard switching applications.

This technical manual includes the evaluation board schematic, circuit description, a quick-start guide and measurement results.

## Evaluation Kit Contents and Requirements

### Kit Contents

The GS61004B-EVBCD EVB includes the following hardware required to evaluate the GaN E-HEMT Driver.

**Table 1** GS61004B-EVBCD Evaluation Kit Contents

Quantity	Description
1	GaN E-HEMT Driver GS61004B Full-Bridge evaluation board assembly

### Hardware Requirements

In order to evaluate the performance of the evaluation board, the following equipment is required:

- DVM and/or oscilloscope
- Function generator (PWM)
- High voltage DC power supply
- DC power supply
- DC test leads
- Loudspeaker or resistive load
- 3-way Molex KK type mating connector, crimp and cable for P1 (Mouser parts: 538-79758-0015, 538-10-11-2033)

## Evaluation Board Assembly Overview

The evaluation board (EVB) is assembled with two PE29102 GaN E-HEMT drivers and four GS61004B E-HEMT transistors. Headers are included for signal input, signal output, and power connections. Probe points are included for waveform measurements. Provision has been made for a single, suitable heatsink to be fastened against the four E-HEMTs, using the three holes in the center of the board.

Figure 1 • GS61004B-EVBCD Evaluation Board Assembly

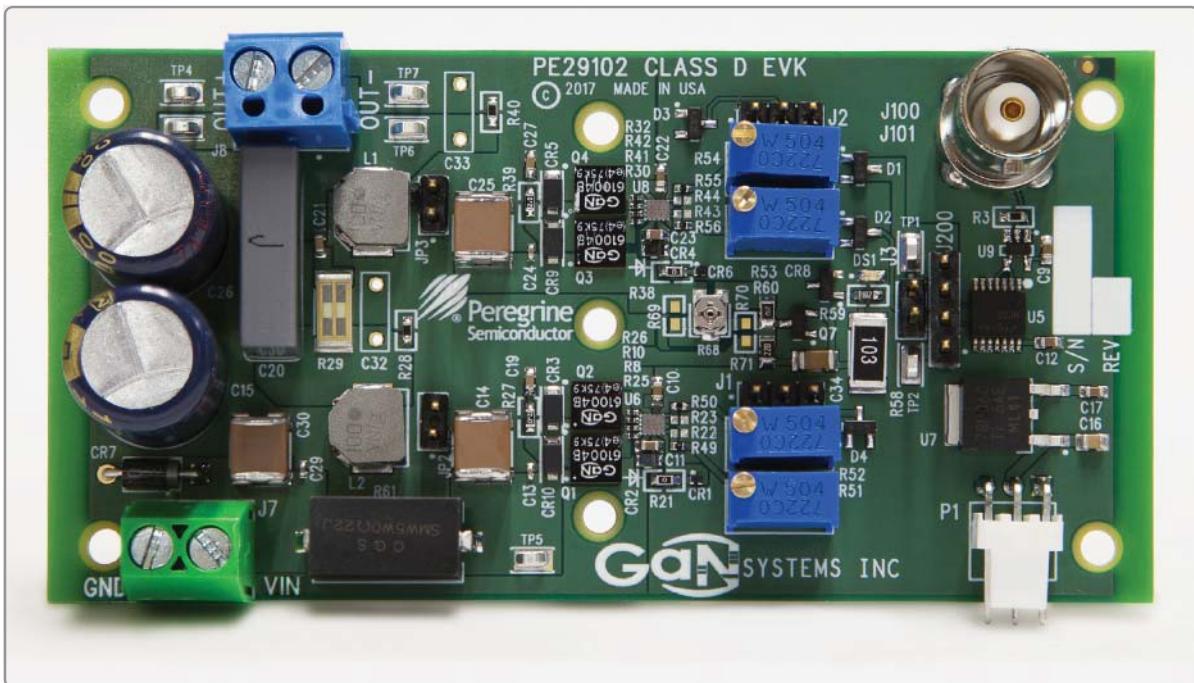

## Block Diagram and Schematic

The block diagram and schematic of the evaluation board are provided in Figures 2, 3, and 4,

**Figure 2 • PE29102 Full-Bridge EVB Block Diagram**

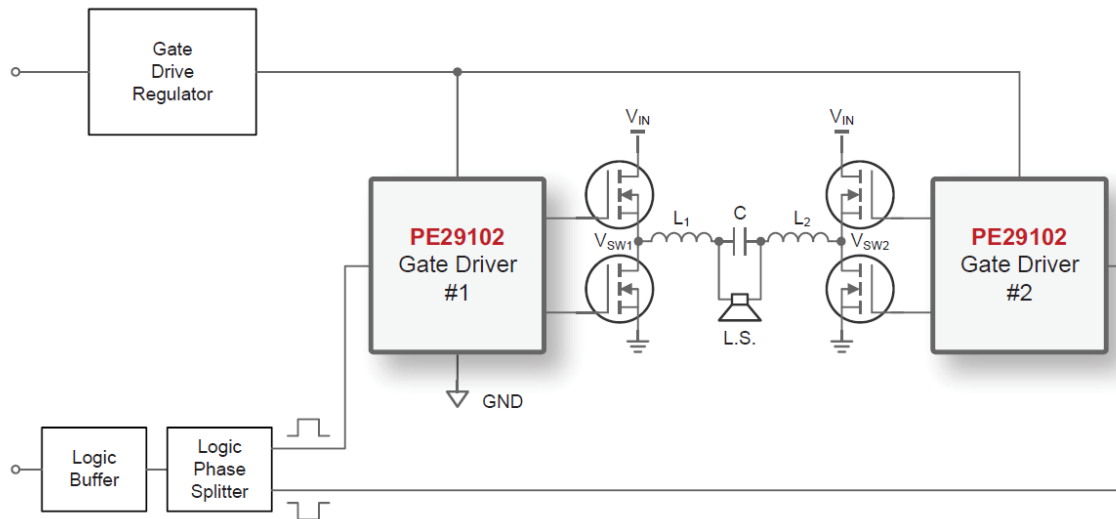
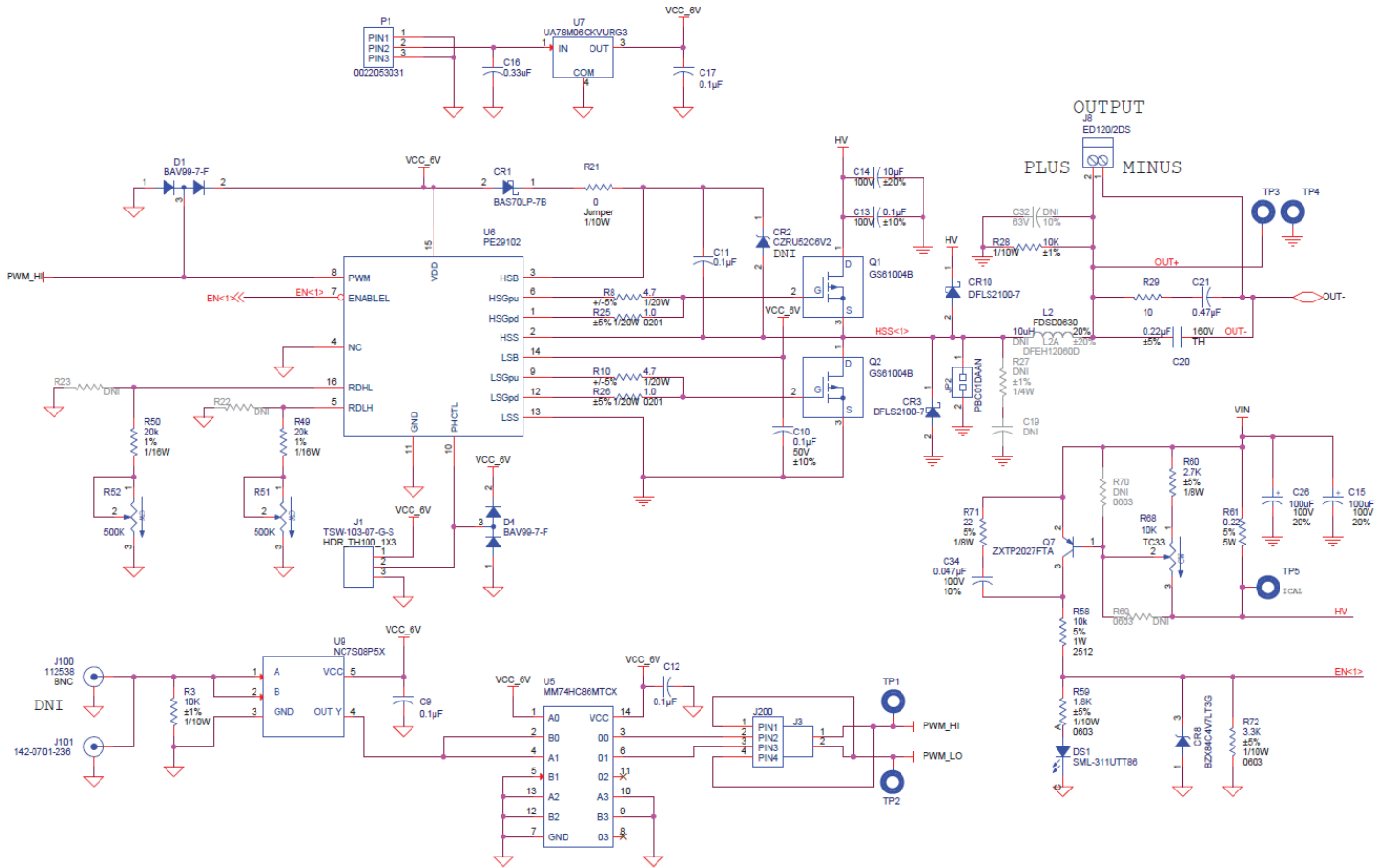
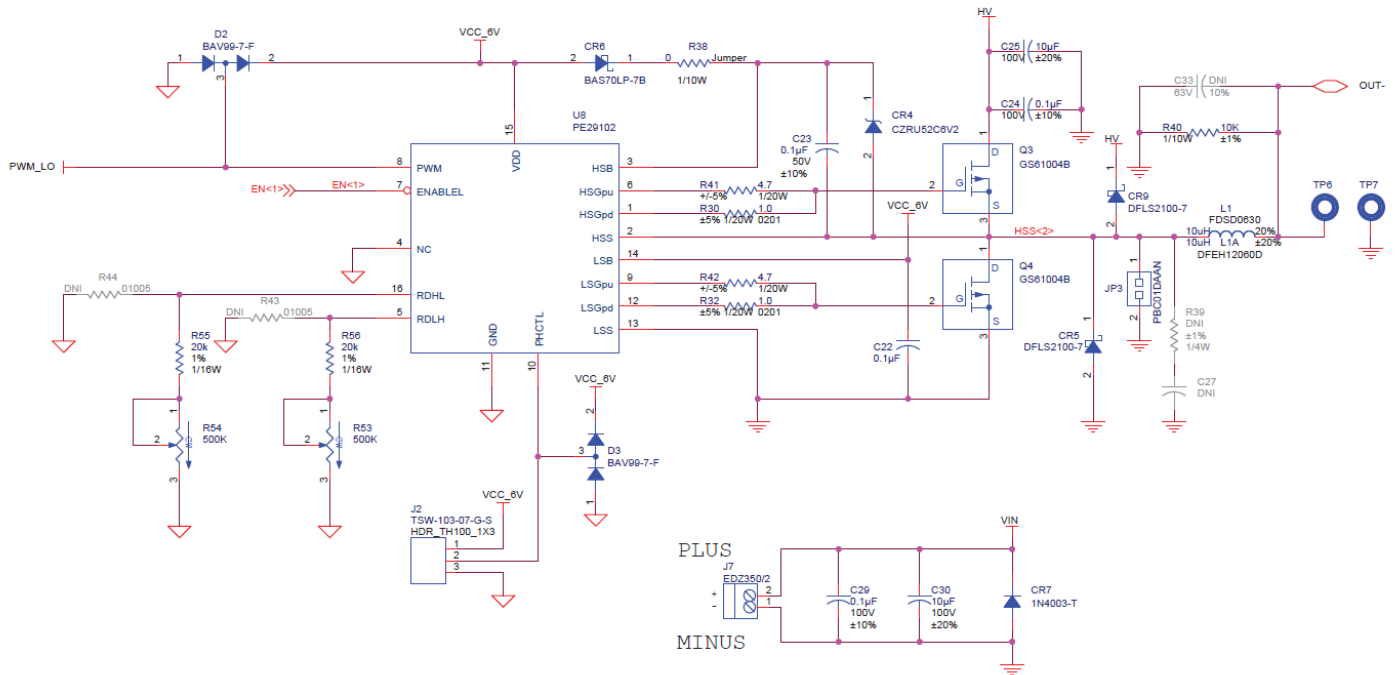

Figure 3 • PE29102 Full-Bridge EVB Schematic (1 of 2)



Note: \* CAUTION: Parts and assemblies susceptible to damage by electrostatic discharge (ESD).

Figure 4 • PE29102 Full-Bridge EVB Schematic (2 of 2)



Note: \* CAUTION: Parts and assemblies susceptible to damage by electrostatic discharge (ESD).

## Circuit Description

The full-bridge circuit comprises two half bridges which share a common supply and load.

The high voltage (+12 to  $\approx$ 30V DC max) to the high-side GS61004B E-HEMTs are fed via J7 and then through the overcurrent protection circuit around Q7, which is described separately. The low-level logic circuitry is supplied by a 6 Volt regulator U7, which is fed separately through P1 with +8 to +24V DC (nominal +12V DC). This feeds the optimal 6V to both of the PE29102 drivers U6 and U8, which are driven independently by a common logic X-OR gate Phase Splitter (Inverter) configuration U5, which is in turn driven by a single input buffer, U9. The latter two devices are also capable of 6V operation.

Typically, the PWM signal is brought in at J100/101 (usually a 50 Ohm BNC socket, though SMA and SMB options are possible) on 50 Ohm coax (for example, RG174) and terminated with R3, whose value is chosen to present a light, rather than matched, load into U9.

Jumpers J200 and J3 are provided to allow for experimental choices of phasing of the two half-bridges, the default setting being that each half bridge driver IC is fed with opposing phases. Each PE29102 has a pin (10) that allows for local phase reversal by fitting and changing one or both jumpers J1 or J2. Both options have been included on the board to allow for maximum flexibility as well as some empirical lab-testing to evaluate the relative merits of either approach in practice.

Test Points TP1 and TP2 allow for convenient oscilloscope monitoring of the jumper-configured drive waveforms derived from the PWM input.

The propagation delays between the PWM input at J100/101 and the output switching nodes at JP2 and JP3 are of the order of 45 ns. This reduces to approximately 10 ns if the TTL/XOR circuitry is bypassed and disconnected by taking the PWM input signal directly to TP1 and TP2 and disconnecting any jumpers fitted to J200. Then the required phase inversion for complementary full bridge operation can be performed by switching over either of the PHCTL jumper links J1 or J2, but not both. This also improves relative timing and symmetry compared to the "stock" TTL/XOR phase inversion, should this be required in critical or higher frequency applications.

Trimpots R51 and R52 adjust the dead time for driver U6, and similarly R53 and R54 do the same for U8. These allow the user to minimize the dead-time between one transistor turning off and the other turning on, thus eliminating any inefficient and potentially damaging large shoot-through currents. Each trimpot includes a series 20k ohm resistor to ensure that the dead-time resistors are never shorted. The relative HSG (High Side Gate) and LSG (Low Side Gate) timing diagrams are shown in Figure 4. Diodes D1 – D4 are used to protect the related pins on the PE29102 to avoid accidental damage when changing or removing various jumpers. Each PE29102 drives the respective high and low side E-HEMTs via low value resistors (R8, 25, 10 and 26; R41, 30, 42 and 32) which tame the parasitic inductances on the transistor gate loops, damping any resonances.

A Zobel network (a.k.a. "Snubber" or "Boucheret Cell") may be connected from each switch node to ground to tame the high frequency response of the circuit when confronted with a complex reactive



load, such as a loudspeaker. A common mode, lower frequency version of these is also provided downstream of the audio filter by R29 and C21. Diodes CR10, 3, 9 and 5 protect the switch nodes from being taken either above the HV supply rail range or below ground. CR7 protects against accidental polarity reversal at the input, but only up to 1 Amp – so at first, power up here using a suitably safe low current limit setting (for example, 100mA).

Capacitors C11 and C23 (in conjunction with diodes CR1 and 2 and CR4 and 6, respectively) provide the bootstrapping action for each of the high side device gate drives.

The capacitor C20 forms a low-pass filter with L1 and L2 from each pair of E-HEMTs, rolling off the frequency response at 12 dB/Octave above approximately 107 kHz. All other capacitors are for local decoupling of the various stages of this high-frequency circuit.

The main output is on J8 which connects to a loudspeaker for audio use: Note that these terminals should be left "floating" (that is, isolated from ground at all times). There is a high-impedance DC path provided by R28 and R40, plus the optional filter capacitors C32 and 33, which are not normally installed. TP3 and 4 and TP6 and 7 provide a way to monitor either side of the output relative to ground using an oscilloscope. DO NOT ground TP6 or TP3. JP2 and JP3 provide a way to monitor each switch node to ground on an oscilloscope. TP5 is used to provide a monitor point for the HV rail as well as a passive or electronic load connection to ground so as to set/ calibrate the maximum current threshold that protects the output devices.

**Figure 5 • PE29102 Dead-time Waveforms**

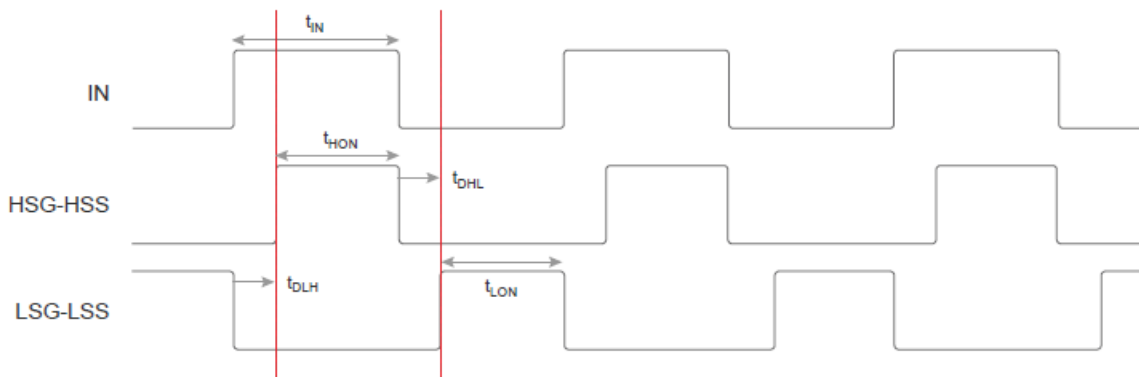
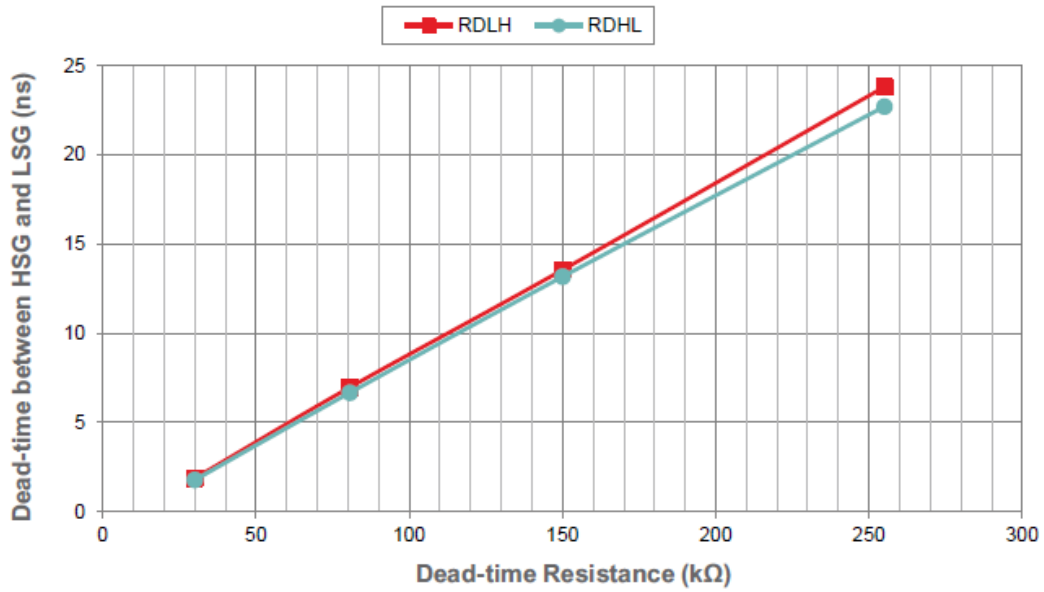

Figure 6 • Dead Time vs Dead Time Resistor



## Overcurrent Protection Circuit

Both half-bridges that comprise the full-bridge are protected by a common over-current detection circuit. This senses high-side current draw through either or both GaN E-HEMT paths to ground (for example, in the event of shoot-through or a short-circuit, etc.).

The main supply input  $V_{IN}$  is decoupled by two electrolytic capacitors (C15 and C26) in parallel to reduce ESR. That supply voltage is fed to each set of GaN E-HEMTs via a 5 Watt, 0.22 ohm resistor (R61). Each stack of E-HEMTs has a local decoupling capacitor C14 (and C25) with a parallel film capacitor C13 (and C24) for improved decoupling at the high switching frequencies.

A test point (TP11) on the E-HEMT side of this resistor (R61) can be used to monitor the supply and/or apply a calibration load to ground to set the threshold at which the limit occurs.

When current is drawn through R61, a voltage develops across it that is scaled by various fitted resistors (R60, R69 and R70) and is made continuously adjustable with a trimpot (R68), when fitted. The proportional voltage is presented to the b-e junction of the PNP high-voltage transistor (Q7), which turns on rapidly when this exceeds ~0.7V.

When Q7 is turned on, current flows through R58 and sets a limited voltage on CR8 of 4.7V, which is used to provide a logic "high" rectangular signal to the "ENABLEL" pins on both PE29102 gate drivers simultaneously. This, in turn, inhibits the outputs and removes drive to all the switching E-HEMTs until the excess current draw stops. An LED (DS1) is fitted to indicate such an event, as well as to provide a simple visual indication of the limit being set, when using a constant applied DC or fixed resistive calibration load.

C34 provides some pulse-stretching to ensure a reliable trigger, as well as to make the LED illuminate sufficiently long enough for the human eye to register even a brief "event".

R71 protects transistor Q7 from otherwise excessive transient discharge current from the shorting of capacitor C34, which could reach within 5V of the applied  $V_{IN}$  voltage.

Figure 7 • Overcurrent Protection

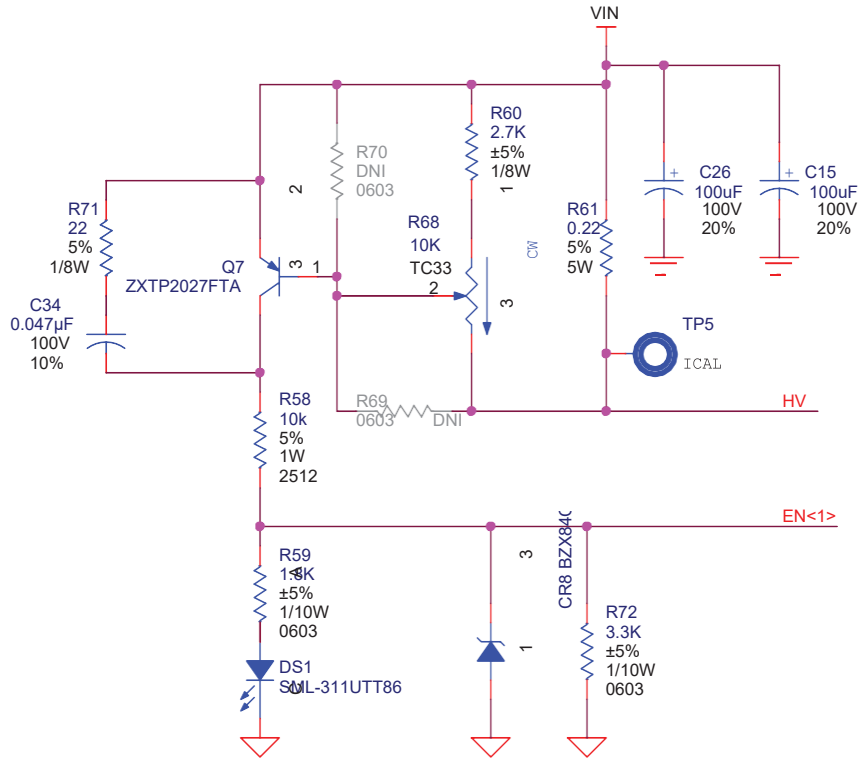

## Quick Start Guide

The GS61004B-EVBCD EVB is designed to ease customer evaluation of the PE29102 Full-Bridge E-HEMT Driver. This chapter will guide the user through the evaluation board overview, hardware operation, test setup and test results.

## Evaluation Board Overview

The GS61004B-EVBCD evaluation board contains:

- Terminal Block connectors for power, BNC coaxial PWM input and Terminal Block audio output ports
- Test points, header pins and jumpers for performance verification
- Output Filters included (Note that blocking capacitors are required if converting to two half bridges)
- Molex power connector for P1 DC input

The operating specifications of the evaluation board are as follows:

- Maximum input operating voltage of 30V (Maximum voltage is limited to 30V based on inductor selection. Maximum voltage can be increased to 60V using inductors with higher voltage rating.)
- Maximum output current of 12A continuous (default setting, adjustable)<sup>(\*)</sup>
- Frequency of operation of 200 kHz – 400 kHz.
- Minimum high-side output pulse width of 3 ns
- Minimum low-side output pulse width of 3 ns

**Note:** \* Maximum load current depends on die temperature and is further subject to switching frequency and operating voltage. Forced air cooling or heat sinking can increase current rating.

## Evaluation Test Setup

Figure 8 through Figure 12 show the test setup for the PE29102 Full Bridge EVB setup. Make sure that the specified safety precautions mentioned in “Safety Precautions” on page 2 are followed.

**Figure 8 • Connectivity**

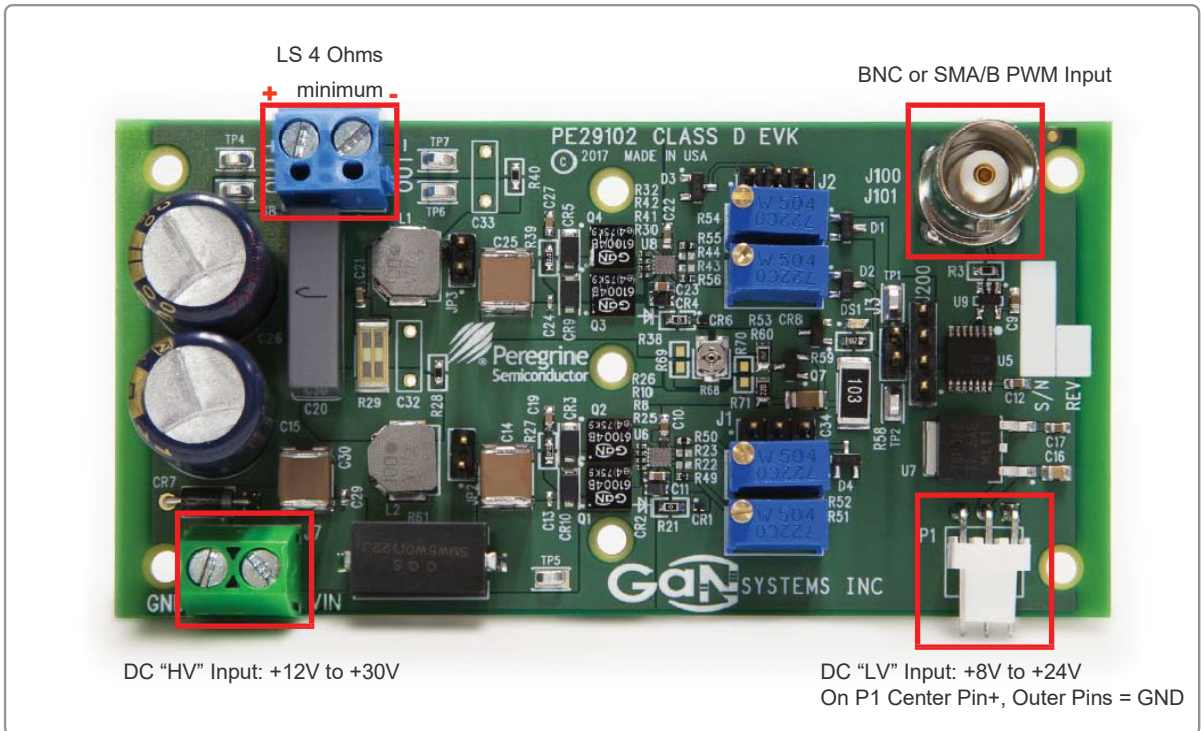

Figure 9 • "XOR" Derived Phase Inversion Jumper Settings

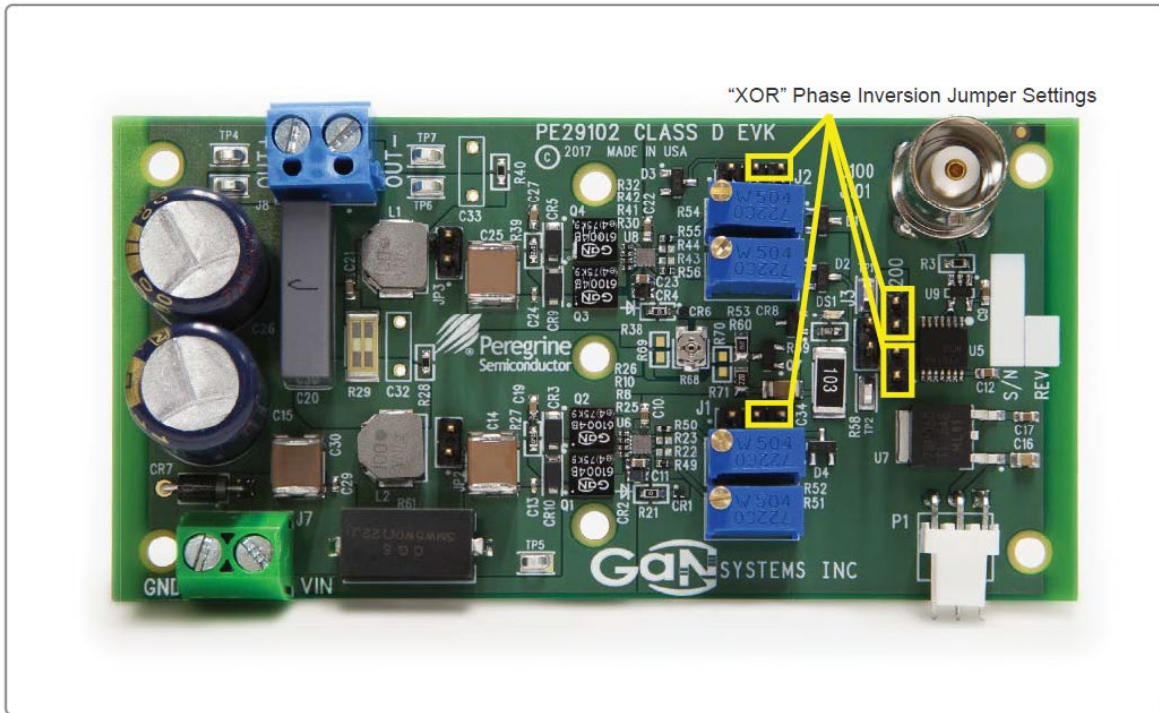

Figure 10 • Jumper Settings for PE29102 Derived Phase Inversion

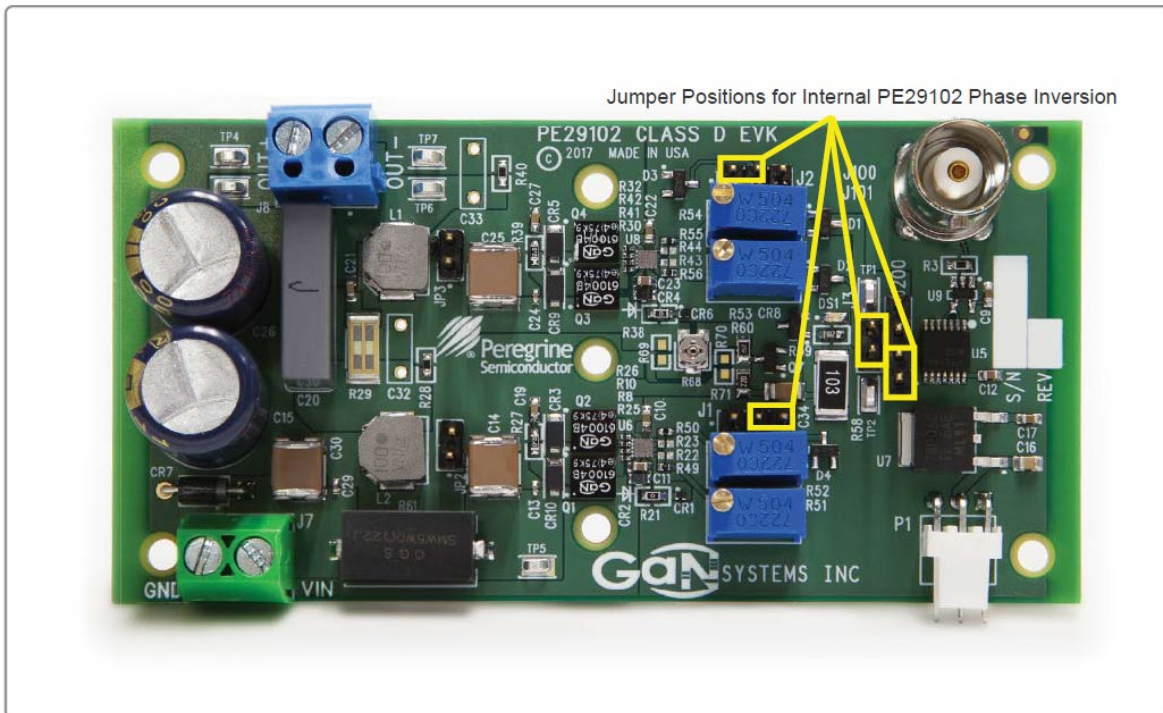

Figure 11 • Adjustments and Indicator

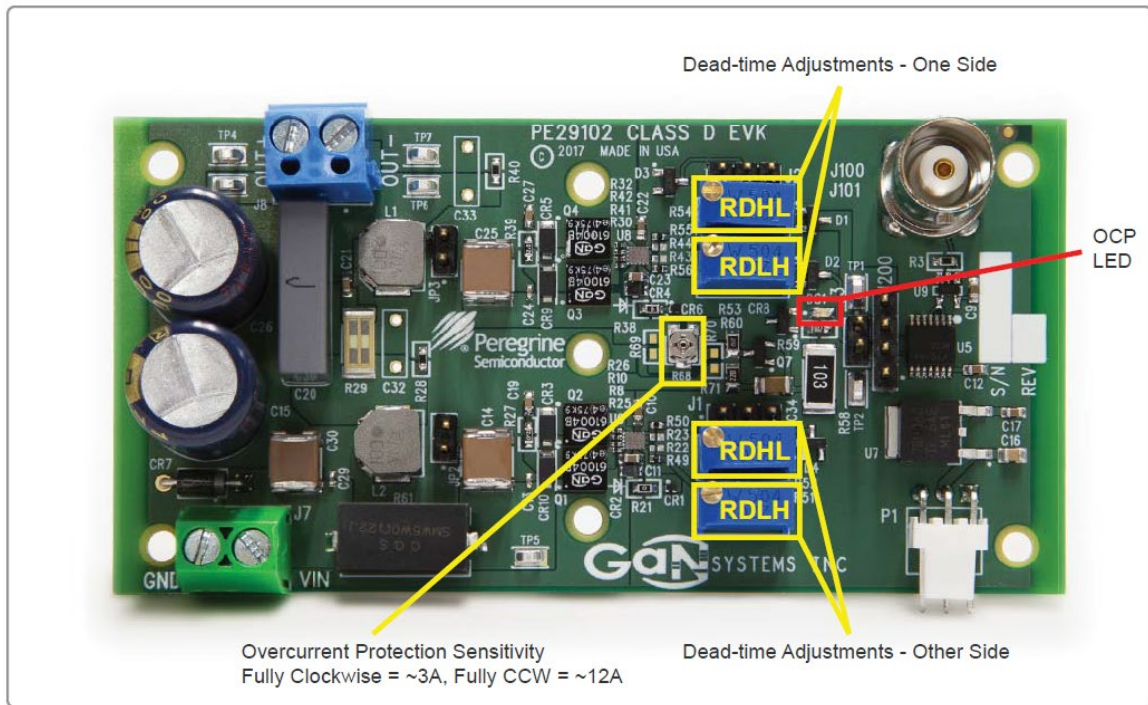
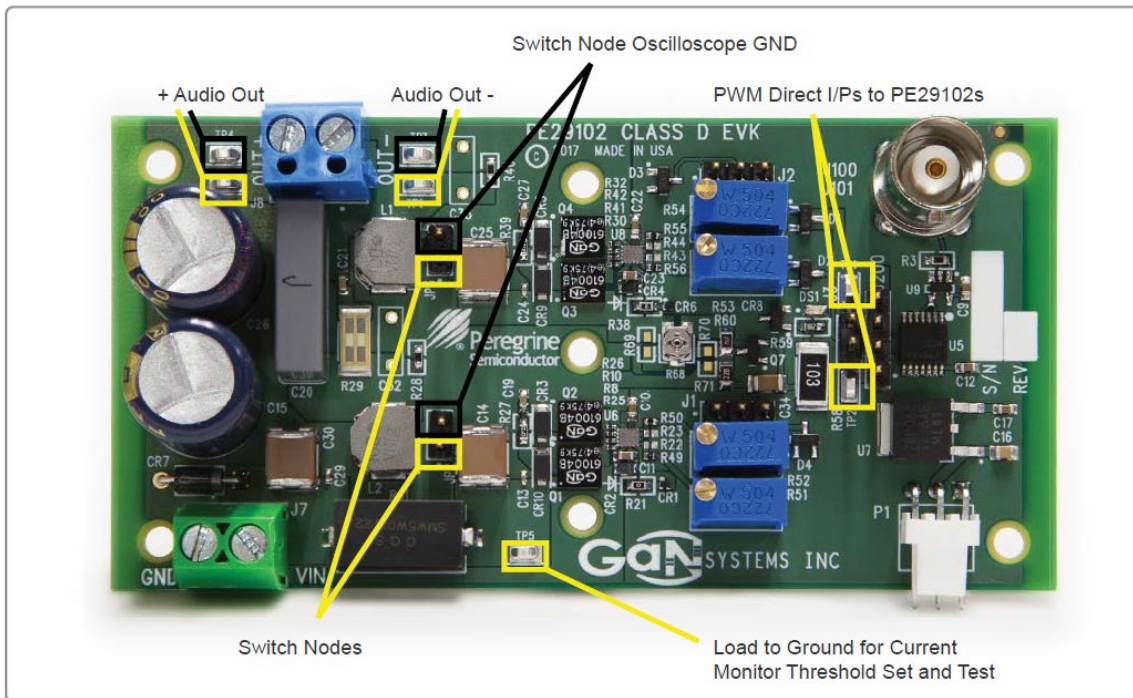

Figure 12 • Test Points





## Hardware Operation

The general guidelines for operating the evaluation board are listed in this section. Follow the steps to configure the hardware properly for operation.

- 1) Before proceeding, set the current limits to 0.5 A for the nominal +12V DC  $V_{DD}$  supply feeding P1 (to begin, start with 1A for the HV supply  $V_{IN}$  feeding J7 at your chosen voltage of between +12 and +30V DC). Then verify that all DC power supplies are turned off.
- 2) Verify that the dead time resistors R51, R52, R53 and R54 are all set to approximately 75 k $\Omega$ . Turning R68 fully clockwise establishes an overcurrent limit of approximately 3A on the PCB. At a later time, this setting can be advanced fully counter-clockwise to set a maximum on-board limit of approximately 12A, while mid- way/center (as shipped) should correspond to approximately 8A.
- 3) Connect the  $V_{DD}$  power supply to P1, +ve is to the center pin, with the outer two pins being GND/0V.
- 4) Apply between +8 and +24V DC to P1 to power the PE29102 driver. With no load or HV supply yet connected, the current consumption should be ~20 mA.
- 5) Connect the input PWM control signal to J100. In the absence of a periodic rectangular waveform (which when present should be no greater than 80% duty cycle), device overheating may occur when in a permanent “high” quiescent state when a load is connected.
- 6) Set the function generator output impedance to 50 $\Omega$  and supply a pulse output of 5V<sub>PP</sub> at 2.5V offset. Start with a 50% duty cycle at a frequency between 200 and 400 kHz. Increase in the current consumption at P1 to ~25mA. With a dual-trace oscilloscope, use two probes to check that two anti-phase square waveforms are present on TP1 and TP2 as long as the jumper settings on J200 and J3 are set for this.
- 7) Connect the input power supply bus  $V_{IN}$  (+) and (-) to J7. Use the 1A current limit on the supply until correct operation is established. This, and the Overcurrent protection threshold trimmer R68, may be increased/ rotated counter-clockwise accordingly.
- 8) Turn on the bus voltage to the required value. Do not exceed the absolute maximum voltage of +30V DC.
- 9) Connect a loudspeaker or resistive load to J8.
- 10) Once operational, adjust the bus voltage and PWM control within the operating range and observe the output switching behavior at test points JP2 and JP3. Exercise care not to short these nodes to their adjacent ground pins.
- 11) Apply the modulating PWM input signal. As switching frequency and output load increase, exercise care not to exceed the junction temperature of the devices.

---

12) To power down the evaluation board, follow the above steps in reverse.

**Note:** When measuring the high frequency content switch node, care must be taken to avoid long ground leads. Measure the switch node by placing the oscilloscope probe tip at JP2 and JP3 (designed for this purpose). See **Figure 13** for proper probe technique.

**PWM signal definition:** A 5V amplitude, TTL compatible (i.e., 2.5V offset) rectangular pulse wave with a nominally 50% duty cycle, whose pulse width may be increased to 80% (or 5:1 Mark:Space ratio) to achieve maximum modulation depth for Class D pulse width modulated switching of the Full Bridge. A 50:50 square wave will produce the smallest output because each half of the bridge is modulated by an equal and opposite amount.

**Figure 13 • Proper Oscilloscope Probe Measurement Technique**

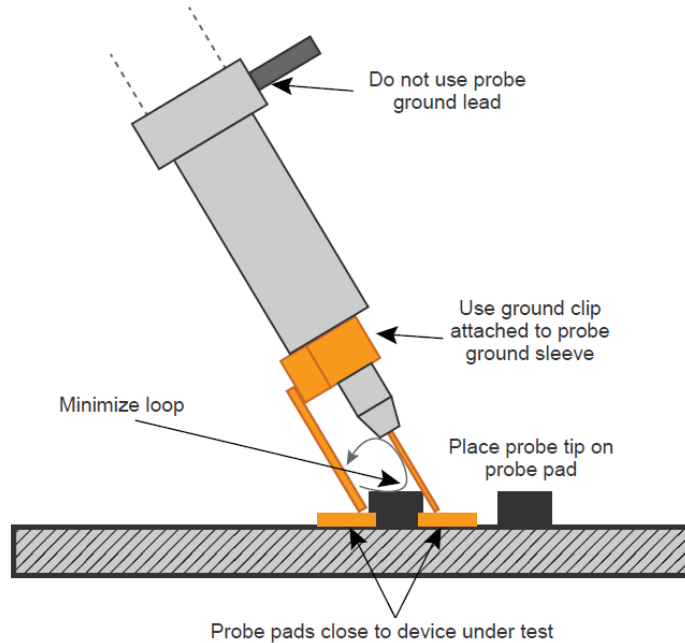

## Current Limit Calibration and Test Procedure

All units are pre-calibrated and tested to a maximum current limit of 10 Amperes. To alter that, use the following procedure.

- 1) Using Ohms law, calculate and choose a representative maximum chosen resistive or active load (representing no more than 14 Amps). This connection should be made between TP5 and ground, using sufficiently thick, short wires.
- 2) Disconnect all signal inputs and outputs. Connect the low voltage (~12V DC) supply to P1, taking care of the polarity.
- 3) Limit the current here to ~0.1A in case of accidental polarity reversal, and then apply the chosen High Voltage (up to 30V DC) to J7.
- 4) Once correct polarity is established, raise the current limit until the full supply voltage at J7 is reached.
- 5) Adjust R68 until the LED DS-1 just extinguishes. The current limit now matches what you are loading TP5 with to ground.
- 6) Power down and disconnect load. The board is now ready for use.

## Evaluation Results

The evaluation results are shown in Figures 14 to 16.

Figure 14 • Oscilloscope Plot Showing Both SW Node Signals (Central Trace Shows PWM Input Signal)

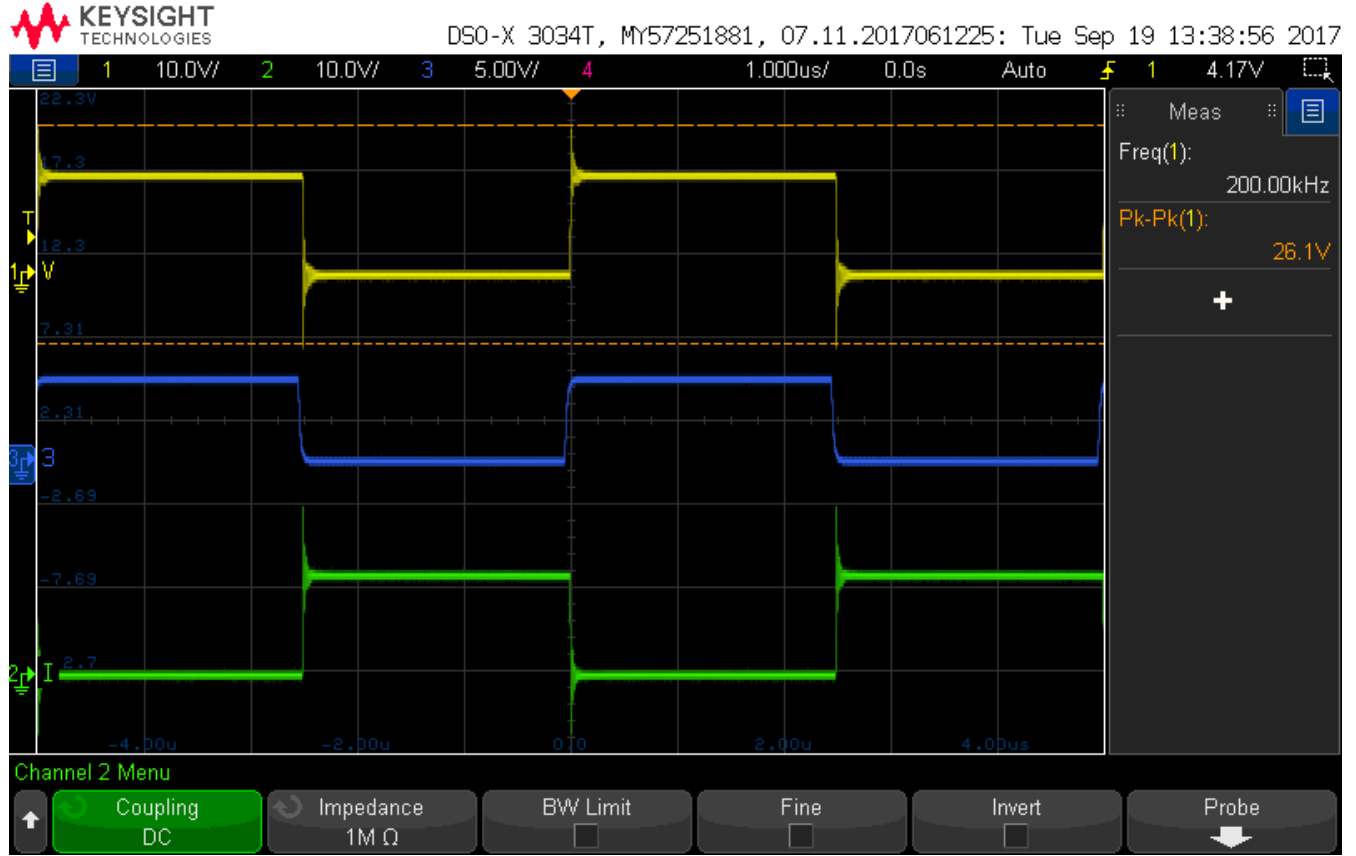

**Figure 15 • Audio 1 kHz Sine Wave Signal Recovered at Loudspeaker Output from a 200 kHz PWM Input Signal (Shown in the Background)**

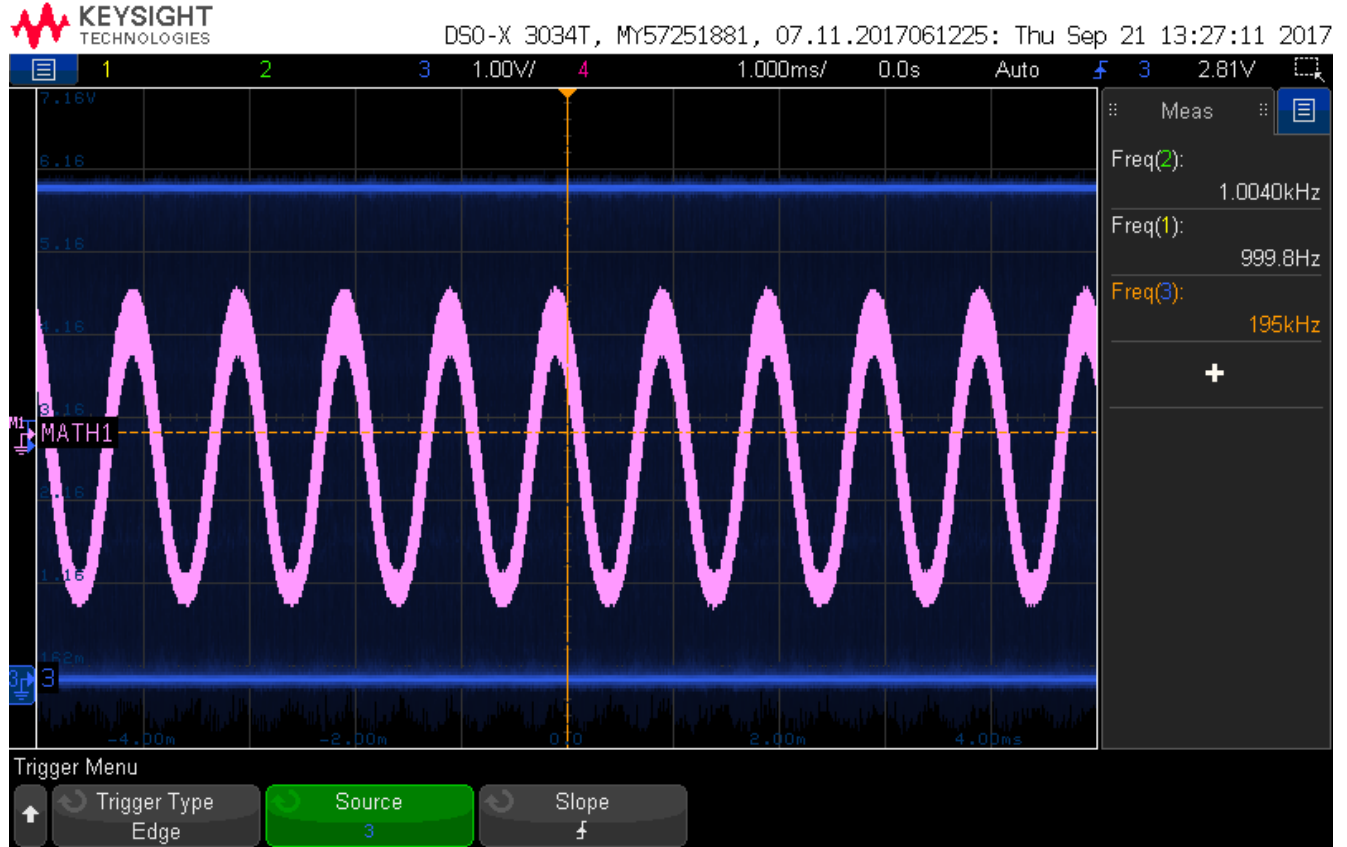

**Figure 16 • GS61004B-EVBCD Efficiency (%) Plotted Against Output Current (in A) with a 30V DC Supply and Output into an 8 Ohm Resistive Load, by Varying the Mark:Space Ratio of a 384 kHz PWM Signal**

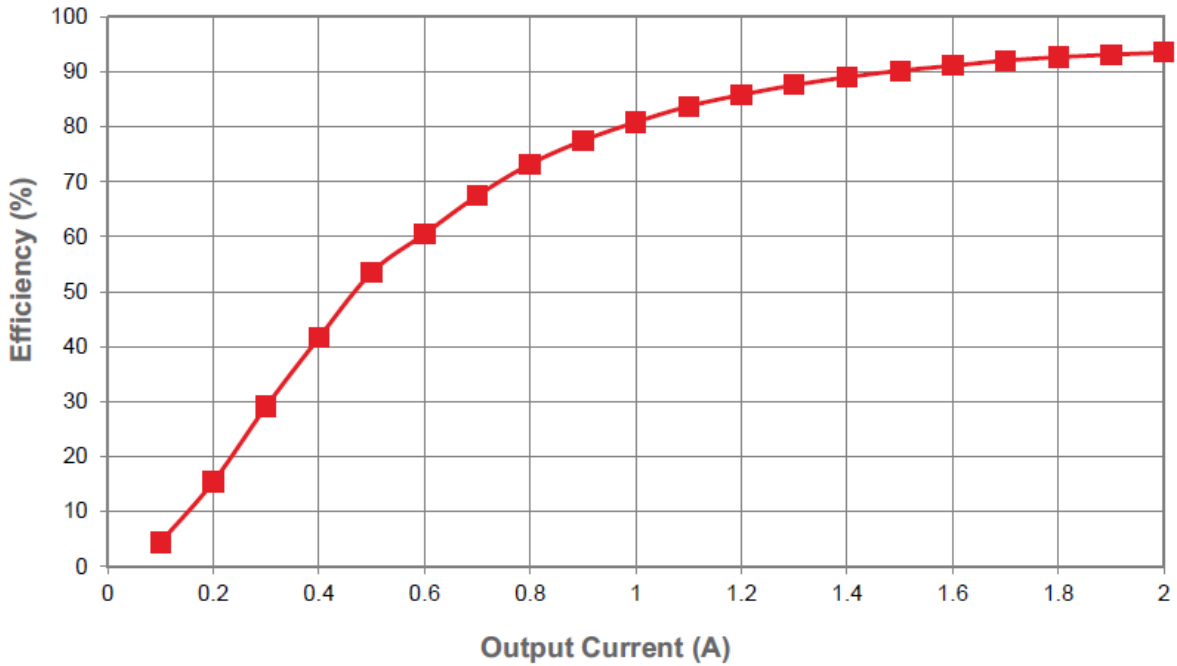

## Thermal Considerations

The evaluation board includes four GS61004B transistors. Although the electrical performance surpasses that for traditional silicon devices, their relatively smaller size does magnify the thermal management requirements. The evaluation board is intended for bench evaluation with low ambient temperature and convection cooling.

The addition of heat-sinking and forced air cooling can significantly increase the current rating of these devices, but care must be taken to not exceed the absolute maximum die temperature of +125 °C.

The thermal performance of the GS61004B-EVBCD evaluation board is shown in Figure 17.

**Figure 17** • GS61004B-EVBCD EVB Thermal Plot Showing Maximum of 57 °C with PWM 1.26 μS Pulse Width at 200 kHz, with 30V @1 A on HV PSU into 8 Ohm Resistive Load

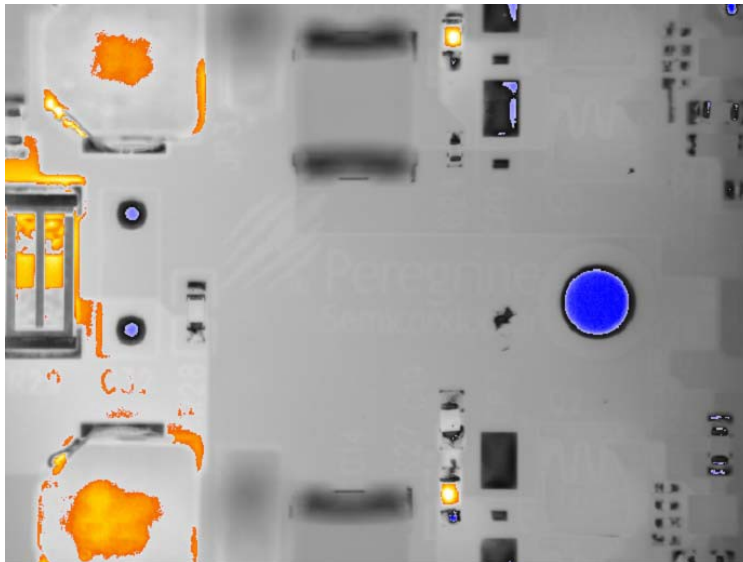

With a 5:1 duty cycle corresponding to a near-maximum pulse width modulation index into a suitable load, the hottest components are the resistors in the Zobel/Snubber Networks (if/when fitted) and the inductors. However, in the absence of a periodic PWM input, the steady DC quiescent state will draw a significantly higher standing current through the GaN E-HEMTs consequently, care and heatsinking considerations will be required to accommodate the resulting increased temperatures.

**Note:** The switch node snubber networks were fitted at the time the thermal images were taken: that is, R39 and C27, R27 and C19, whose resistors will become hot if fitted, as seen in these images. Leaving these parts unfitted should improve efficiency slightly

## Guidelines for Half-Bridge Stereo Audio Operation

This Full Bridge design can be operated as two independent half-bridges by performing the following simple modifications:

- 1) Remove C20, C21 and R29.
- 2) Fit a pair of 63V or greater 0.22  $\mu$ F film capacitors to positions C32 and C33. These are essential to form the output low pass filters with L2 and L1, respectively in the absence of C20.
- 3) Remove any jumper links from J200 and J3, as these would otherwise drive the two half bridges simultaneously, whether in or out of phase. Unless that is still desirable, these jumpers will need to be removed and the incoming PWM signals instead applied directly to TP1 and TP2, for example as a Stereo pair of Left and Right channels. D1 and D2 still protect the PE29102 inputs that are connected. Do not use the coax socket at J100/ 101, as U9 and U5 are now redundant. Pull down resistors to ground may be required from TP1 and TP2 and if so, these should be 10k.
- 4) To avoid using the common output J8, use TP3 and TP4 for one channel and TP6 and TP7 for the other, which will be less confusing.

### Notes:

For an adequate low frequency response, a large electrolytic capacitor (of at least 63V working voltage and a value of at least 2200  $\mu$ F or higher MUST be fitted in series with both TP3 and TP6 or socket J8: each positive capacitor terminal should go to these, respectively. Failing to observe this required DC blocking will result in damage to your loudspeakers.

The loudspeakers must be connected after the DC blocking electrolytic capacitors, then to ground: that is, there must be no DC voltage present across the loudspeaker voice coils.

The negative capacitor terminals should go to the + speaker connections, with the – speaker connections both going to Ground, preferably started from Pin 1 J7, the DC power inlet ground terminal.



Figure 18 • Half-Bridge Stereo Audio Operation Configuration

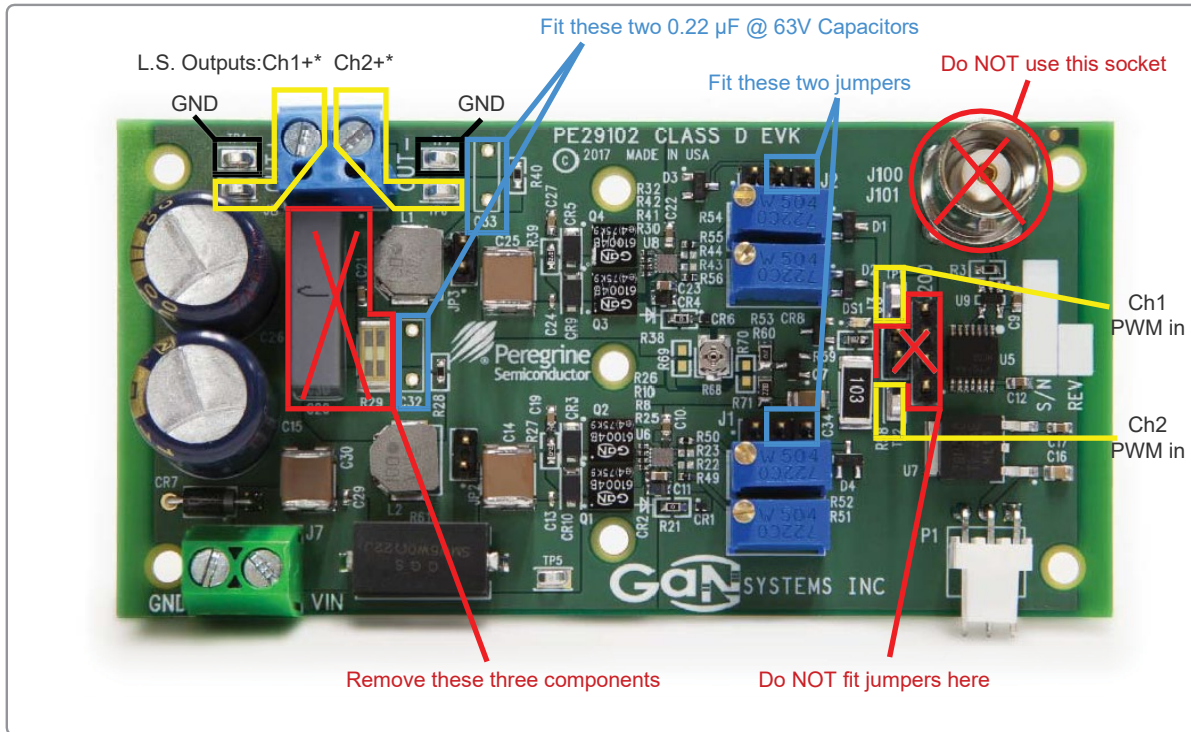

Note: \* Negative LS terminals connect to GND (see Figure 19).

- Connect the positive (+) end of each external 2200  $\mu$ F 63V electrolytic capacitor to each positive (+) PCB output connection.
- Connect the negative (-) end of each of these capacitors to the respective LS positive terminals.
- Negative LS terminals connect to GND (see block diagram).

**Figure 19 • Modified Block Diagram for Independent Dual (Stereo) Half-Bridge Topology**

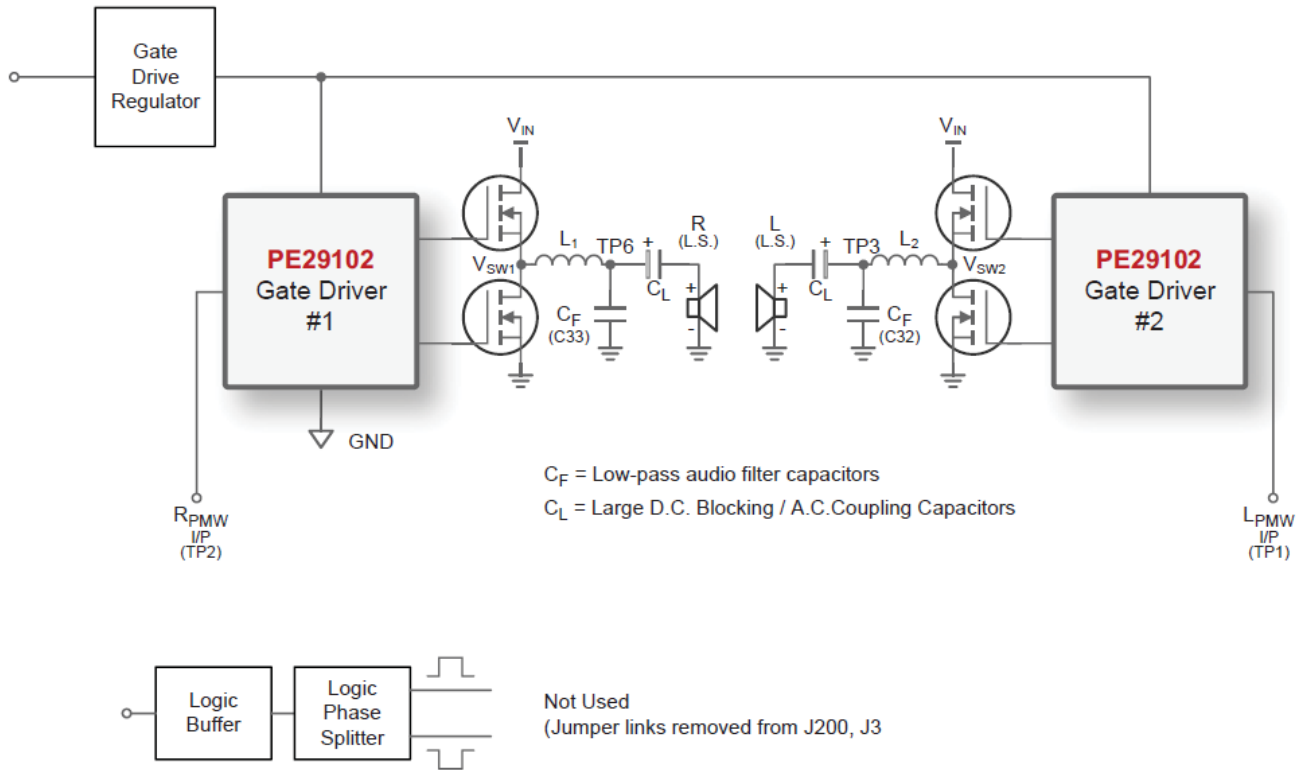

## Technical Resources

This document and additional technical resources are available for download from [www.gansystems.com](http://www.gansystems.com).

**Evaluation Board/kit Important Notice**

GaN Systems Inc. (GaN Systems) provides the enclosed product(s) under the following **AS IS** conditions:

This evaluation board/kit being sold or provided by GaN Systems is intended for use for **ENGINEERING DEVELOPMENT, DEMONSTRATION, and OR EVALUATION PURPOSES ONLY** and is not considered by GaN Systems to be a finished end-product fit for general consumer use. As such, the goods being sold or provided are not intended to be complete in terms of required design-, marketing-, and/or manufacturing-related protective considerations, including but not limited to product safety and environmental measures typically found in end products that incorporate such semiconductor components or circuit boards. This evaluation board/kit does not fall within the scope of the European Union directives regarding electromagnetic compatibility, restricted substances (RoHS), recycling (WEEE), FCC, CE or UL, and therefore may not meet the technical requirements of these directives, or other related regulations.

If this evaluation board/kit does not meet the specifications indicated in the Technical Manual, the board/kit may be returned within 30 days from the date of delivery for a full refund. **THE FOREGOING WARRANTY IS THE EXCLUSIVE WARRANTY MADE BY THE SELLER TO BUYER AND IS IN LIEU OF ALL OTHER WARRANTIES, EXPRESSED, IMPLIED, OR STATUTORY, INCLUDING ANY WARRANTY OF MERCHANTABILITY OR FITNESS FOR ANY PARTICULAR PURPOSE. EXCEPT TO THE EXTENT OF THIS INDEMNITY, NEITHER PARTY SHALL BE LIABLE TO THE OTHER FOR ANY INDIRECT, SPECIAL, INCIDENTAL, OR CONSEQUENTIAL DAMAGES.**

The user assumes all responsibility and liability for proper and safe handling of the goods. Further, the user indemnifies GaN Systems from all claims arising from the handling or use of the goods. Due to the open construction of the product, it is the user's responsibility to take any and all appropriate precautions with regard to electrostatic discharge.

No License is granted under any patent right or other intellectual property right of GaN Systems whatsoever. **GaN Systems assumes no liability for applications assistance, customer product design, software performance, or infringement of patents or any other intellectual property rights of any kind.**

GaN Systems currently services a variety of customers for products around the world, and therefore this transaction **is not exclusive**.

**Please read the Technical Manual and, specifically, the Warnings and Restrictions notice in the Technical Manual prior to handling the product.** Persons handling the product(s) must have electronics training and observe good engineering practice standards.

This notice contains important safety information about temperatures and voltages. For further safety concerns, please contact a GaN Systems' application engineer.