

GTRA214602FC

Thermally-Enhanced High Power RF GaN on SiC HEMT
490 W, 48 V, 2110 – 2170 MHz

Description

The GTRA214602FC is a 490-watt (P3dB) GaN on SiC high electron mobility transistor (HEMT) designed for use in multi-standard cellular power amplifier applications. It features input matching, high efficiency, and a thermally-enhanced package with earless flange.

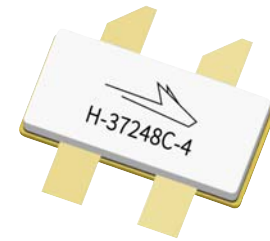

GTRA214602FC
Package H-37248C-4

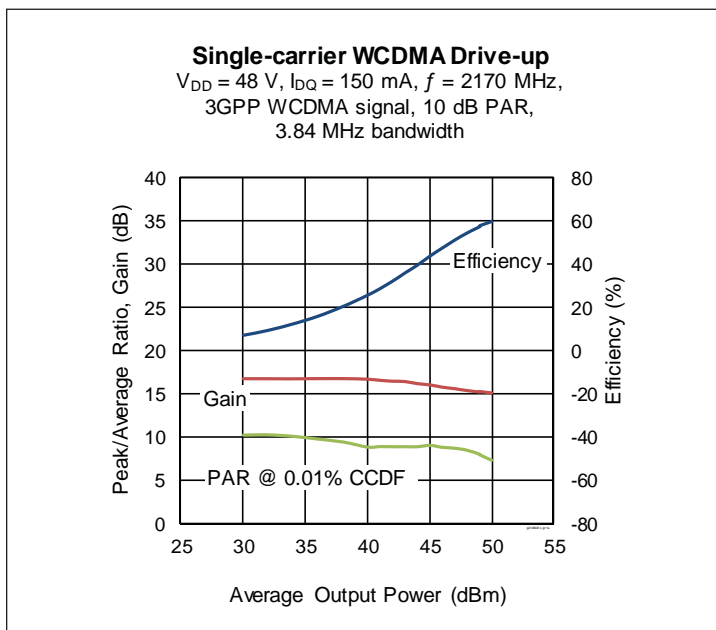

Features

- GaN on SiC HEMT technology
- Input matched
- Asymmetric Doherty design
 - Main: P3dB = 170 W Typ
 - Peak: P3dB = 350 W Typ
- Typical pulsed CW performance: 16 μs pulse width, 10% duty cycle, 2140 MHz, 48 V, Doherty fixture
 - Gain = 15 dB @ 49 dBm
 - Efficiency = 60% @ 49 dBm
 - Output power at P_{3dB} = 490 W
- Human Body Model Class 1B (per ANSI/ESDA/JEDEC JS-001)
- Low thermal resistance
- Pb-free and RoHS compliant

Target RF Characteristics

Single-carrier WCDMA Specifications (tested in Wolfspeed Doherty test fixture)

$V_{DD} = 48\text{ V}$, $I_{DQ} = 150\text{ mA}$, $V_{GS(PEAK)} = -5.5\text{ V}$, $P_{OUT} = 80\text{ W avg}$, $f = 2170\text{ MHz}$
 3GPP signal, channel bandwidth = 3.84 MHz, peak/average = 10 dB @ 0.01% CCDF

Characteristic	Symbol	Min	Typ	Max	Unit
Gain	G_{ps}	13	14.4	—	dB
Drain Efficiency	η_D	56	59	—	%
Adjacent Channel Power Ratio	ACPR	—	-30	-27	dBc
Output PAR @ 0.01% CCDF	OPAR	7.1	8.2	—	dB

All published data at $T_{CASE} = 25^\circ\text{C}$ unless otherwise indicated

ESD: Electrostatic discharge sensitive device—observe handling precautions!



DC Characteristics

Characteristics	Conditions	Symbol	Min	Typ	Max	Unit
Drain-source Breakdown Voltage (main) (peak)	$V_{GS} = -8\text{ V}, I_D = 10\text{ mA}$	$V_{(BR)DSS}$	150	—	—	V
	$V_{GS} = -8\text{ V}, I_D = 10\text{ mA}$	$V_{(BR)DSS}$	150	—	—	V
Drain-source Leakage Current	$V_{GS} = -8\text{ V}, V_{DS} = 10\text{ V}$	I_{DSS}	—	—	5.5	mA
Gate Threshold Voltage (main) (peak)	$V_{DS} = 10\text{ V}, I_D = 20\text{ mA}$	$V_{GS(th)}$	-3.8	-3.0	-2.3	V
	$V_{DS} = 10\text{ V}, I_D = 38\text{ mA}$	$V_{GS(th)}$	-3.8	-3.0	-2.3	V

Recommended Operating Conditions

Parameter	Conditions	Symbol	Min	Typ	Max	Unit
Operating Voltage		V_{DD}	0	—	50	V
Gate Quiescent Voltage	$V_{DS} = 48\text{ V}, I_D = 150\text{ mA}$	$V_{GS(Q)}$	-3.7	-3.1	-2.6	V

Absolute Maximum Ratings

Parameter	Symbol	Value	Unit
Drain-source Voltage	V_{DSS}	125	V
Gate-source Voltage	V_{GS}	-10 to +2	V
Operating Voltage	V_{DD}	55	V
Gate Current (main) (peak)	I_G	20	mA
	I_G	38.4	mA
Drain Current (main) (peak)	I_D	7.5	A
	I_D	14.4	A
Junction Temperature	T_J	225	°C
Storage Temperature Range	T_{STG}	-65 to +150	°C

Operation above the maximum values listed here may cause permanent damage. Maximum ratings are absolute ratings; exceeding only one of these values may cause irreversible damage to the component. Exposure to absolute maximum rating conditions for extended periods may affect device reliability. For reliable continuous operation, the device should be operated within the operating voltage range (V_{DD}) specified above.

Thermal Characteristics

Thermal resistance, junction to case: $T_{CASE} = 70^\circ\text{C}$, 2170 MHz, $V_{DD} = 48\text{ V}$, $I_{DQ(MAIN)} = 150\text{ mA}$, $V_{GS(PEAK)} = -5.5\text{ V}$

Characteristics	Symbol	Value	Unit
Thermal Resistance (main)	$R_{\theta JC}$	2.0	°C/W
(peak)	$R_{\theta JC}$	1.5	°C/W

Ordering Information

Type and Version	Order Code	Package	Shipping
GTRA214602FC V1 R0	GTRA214602FC-V1-R0	H-37248C-4	Tape & Reel, 50 pcs
GTRA214602FC V1 R2	GTRA214602FC-V1-R2	H-37248C-4	Tape & Reel, 250 pcs

Typical Performance (data taken in a Wolfspeed production test fixture)

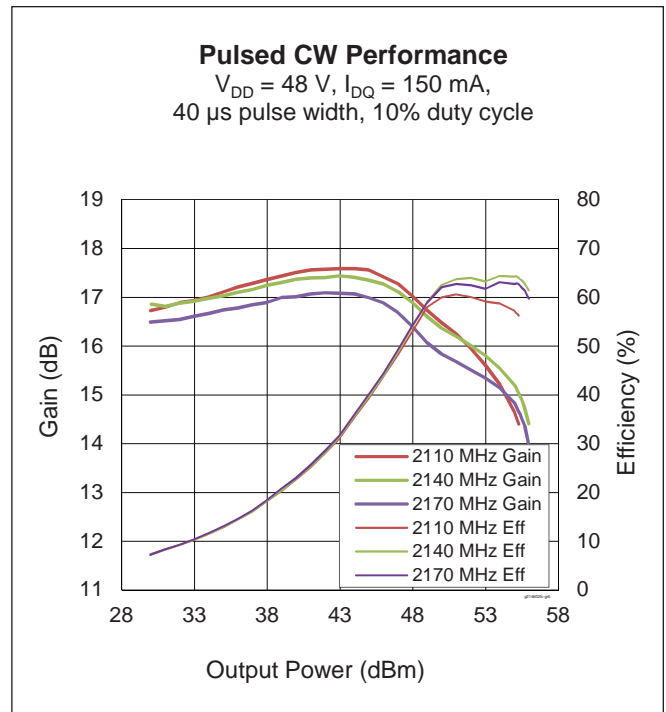
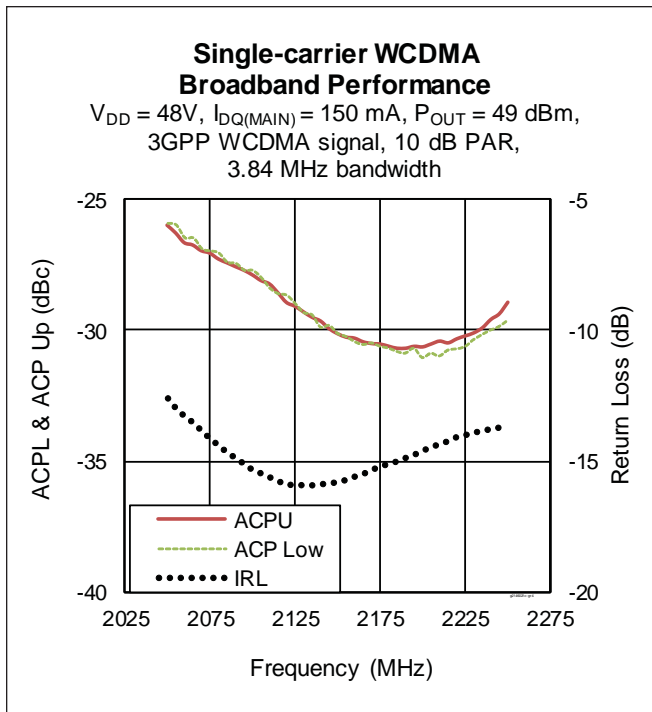
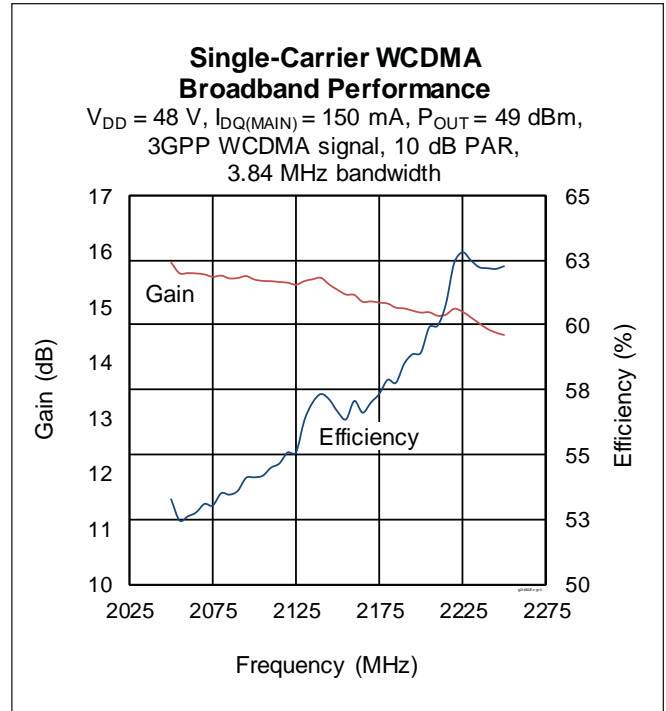
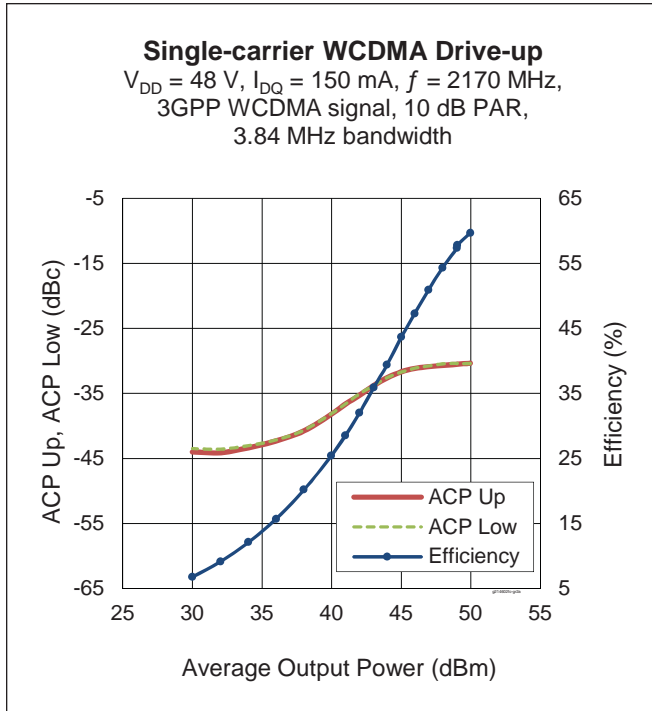

Typical Performance (cont.)

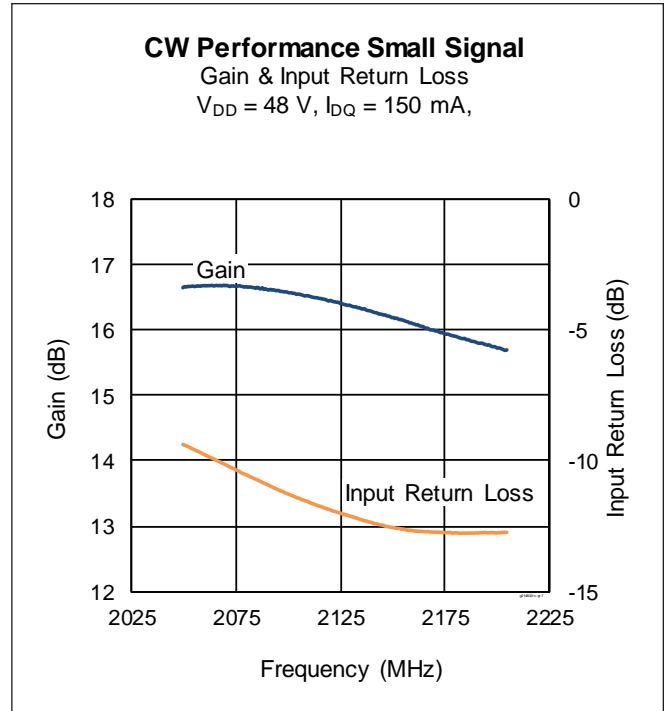
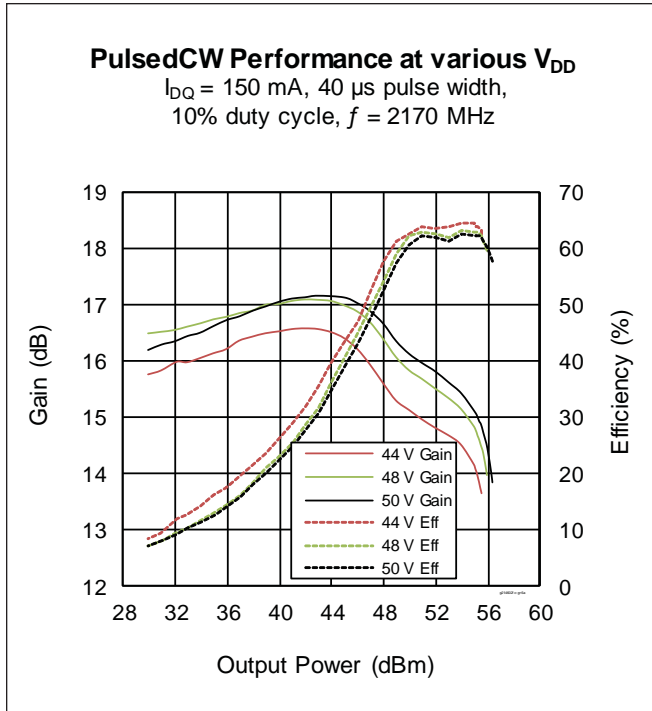

Load Pull

Main Side Load Pull Performance – Pulsed CW signal: 10 μs pulse width, 10% duty cycle; 48 V, $I_{DQ} = 150 \text{ mA}$, class AB

Freq [MHz]	Z_s [Ω]	P_{3dB}									
		Max Output Power					Max Drain Efficiency				
		Z_l [Ω]	Gain [dB]	P_{OUT} [dBm]	P_{OUT} [W]	η_D [%]	Z_l [Ω]	Gain [dB]	P_{OUT} [dBm]	P_{OUT} [W]	η_D [%]
2110	7.7 - j13.6	3.1 - j1.8	17.2	53.00	200	71.0	2.8 + j0.4	18.9	50.90	123	80.8
2140	13.8 - j12.5	3.5 - j2.3	16.6	52.80	191	68.1	2.4 + j0.7	19	50.60	115	83.0
2170	13.0 - j7.0	3.0 - j2.3	16.4	52.80	191	68.1	2.6 + j0.4	18.3	50.80	120	82.5

Peak Side Load Pull Performance – Pulsed CW signal: 10 μsec pulse width, 10% duty cycle; 48 V, $V_{GS(PEAK)} = -3.6 \text{ V}$, class C

Freq [MHz]	Z_s [Ω]	P_{3dB}									
		Max Output Power					Max Drain Efficiency				
		Z_l [Ω]	Gain [dB]	P_{OUT} [dBm]	P_{OUT} [W]	η_D [%]	Z_l [Ω]	Gain [dB]	P_{OUT} [dBm]	P_{OUT} [W]	η_D [%]
2110	5.8 - j9.0	2.4 - j3.7	15.5	56.40	437	67	2.2 - j1.6	17.2	54.60	288	77.2
2140	7.0 - j9.5	2.5 - j3.7	15.5	56.30	427	66	2.2 - j1.8	17.1	54.60	288	76.0
2170	8.2 - j8.0	2.5 - j3.9	15.3	56.40	437	65	2.0 - j1.8	17.5	54.80	302	79.0

Reference Circuit, 2110 – 2170 MHz

Reference Circuit Assembly

DUT	GTRA214602FC
Test Fixture Part No.	LTA/GTRA214602FC-V1
PCB	Rogers 4350, 0.762 mm [0.030"] thick, 2 oz. copper, $\epsilon_r = 3.66$

Find Gerber files for this test fixture on the Wolfspeed Web site at www.wolfspeed.com/RF

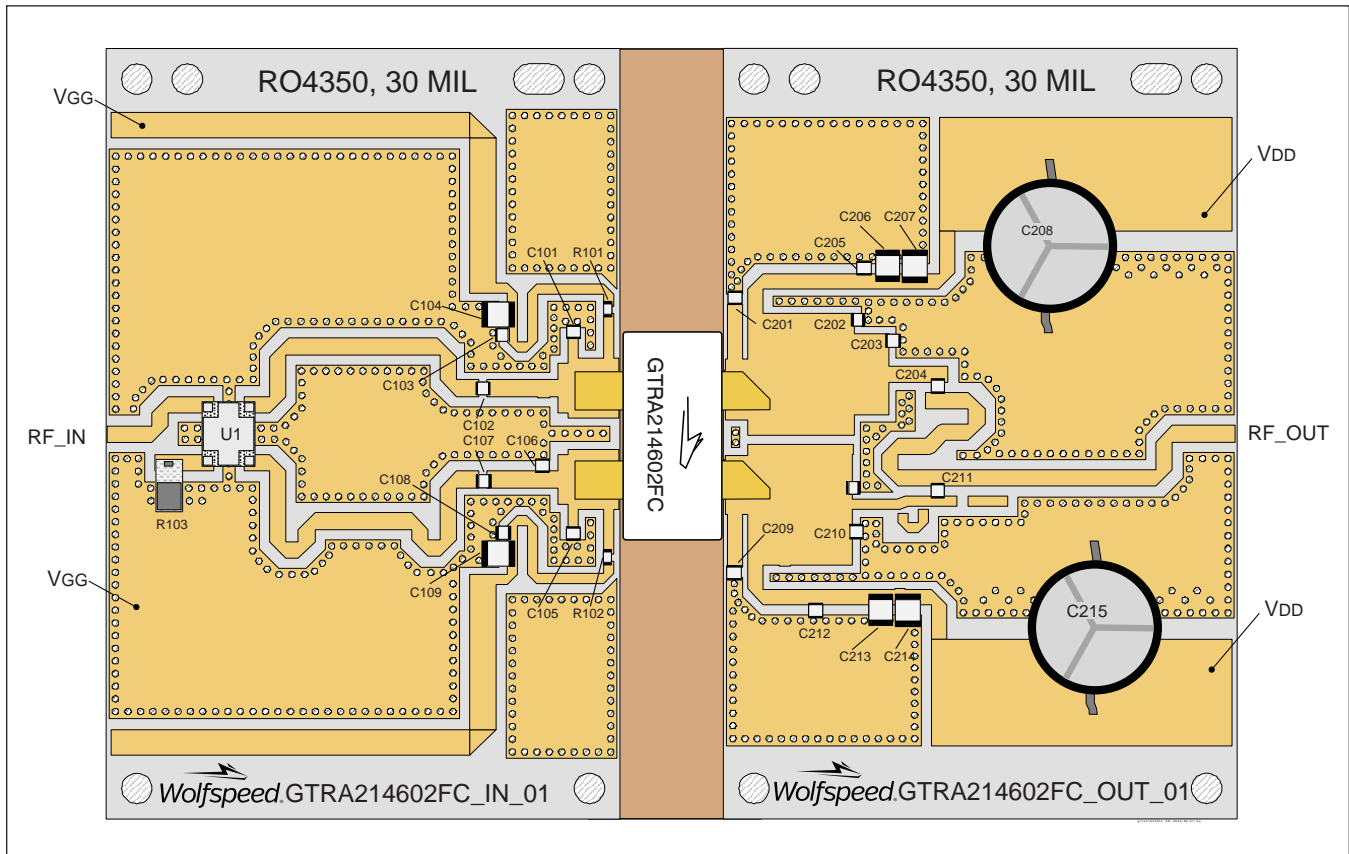

Reference circuit assembly diagram (not to scale)

Bias Sequencing

Bias ON

1. Ensure RF is turned off
2. Apply pinch-off voltage of -5 V to the gate
3. Apply nominal drain voltage
4. Bias gate to desired quiescent drain current
5. Apply RF

Bias ON

1. Turn RF off
2. Apply pinch-off voltage of to the gate
3. Turn off drain voltage
4. Turn off gate voltage



Reference Circuit (cont.)

Components Table

Component	Description	Manufacturer	P/N
Input			
C101, C105	Capacitor, 1.5 pF	ATC	ATC600F1R5BT250XT
C102, C103, C107, C108	Capacitor, 18 pF	ATC	ATC600F180JT250XT
C104, C109	Capacitor, 10 μF, 100 V	Murata Electronics	GRM32EC72A106KE05L
C106	Capacitor, 1.3 pF	ATC	ATC600F1R3BT250XT
R101, R102	Resistor, 9.1 ohms	Panasonic Electronic Components	ERJ-3GEYJ9R1V
R103	Resistor, 50 ohms	Anaren	C8A50Z4A
U1	Hybrid coupler	Anaren	X3C21P1-03S
Output			
C201, C209	Capacitor, 1 pF	ATC	ATC600F1R0BT250XT
C202	Capacitor, 0.9 pF	ATC	ATC600F0R9BT250XT
C203	Capacitor, 0.2 pF	ATC	ATC600F0R2BT250XT
C204	Capacitor, 7.5 pF	ATC	ATC600F7R5BT250XT
C205, C212	Capacitor, 18 pF	ATC	ATC600F180JT250XT
C206, C207, C213, C214	Capacitor, 10 μF, 100 V	Murata Electronics	GRM32EC72A106KE05L
C208, C215	Capacitor, 470 μF, 100 V	Panasonic Electronic Components	ECA-2AHG471B
C210	Capacitor, 0.7 pF	ATC	ATC600F0R7BT250XT
C211	Capacitor, 15 pF	ATC	ATC600F150JT250XT

Pinout Diagram (top view)

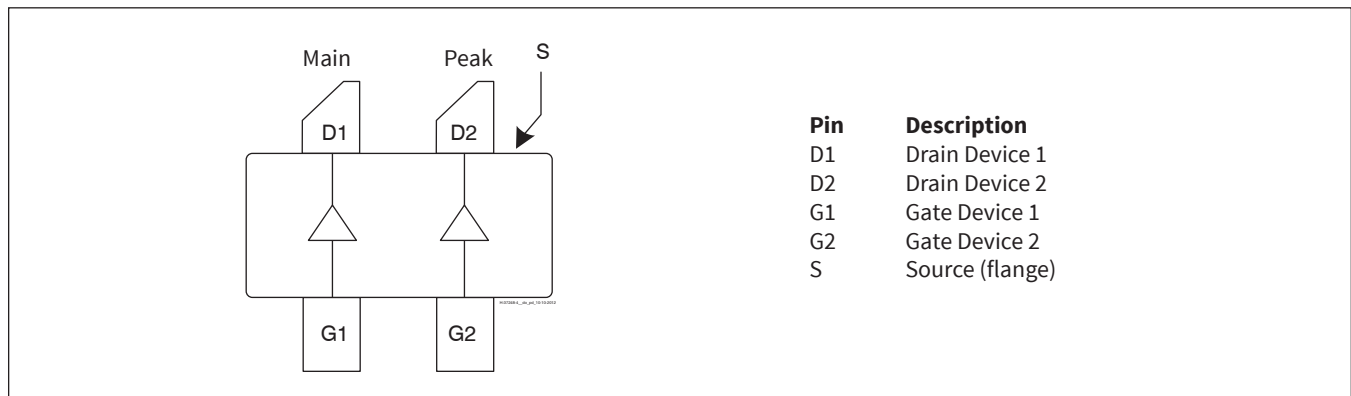

Package Outline Specifications

