

GTVA212701FA

Thermally-Enhanced High Power RF GaN on SiC HEMT 270 W, 48 V, 2110 – 2200 MHz

Description

The GTVA212701FA is a 270-watt GaN on SiC high electron mobility transistor (HEMT) for use in the 2110 to 2200 MHz frequency band. It features input matching, high efficiency, and a thermally-enhanced earless package.



GTVA212701FA
Package H-87265J-2

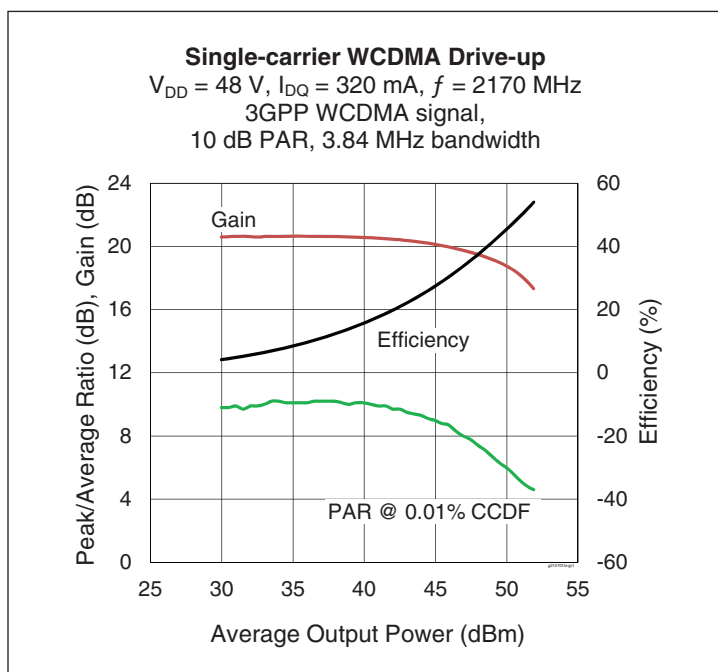

Features

- GaN on SiC HEMT technology
- Input matched
- Typical pulsed CW performance (class AB), 2180 MHz, 48 V, 10 μs pulse width, 10% duty cycle
 - Output power $P_{3dB} = 300\text{ W}$
 - Drain efficiency = 68.5%
 - Gain = 17.5 dB
- Human Body Model Class 1B (per ANSI/ESDA/JEDEC JS-001)
- Capable of handling 10:1 VSWR @ 48 V, 56.2 W (WCDMA) output power
- Low thermal resistance
- Pb-free and RoHS-compliant

RF Characteristics

Single-carrier WCDMA Specifications (tested in Wolfspeed test fixture)

$V_{DD} = 48\text{ V}$, $I_{DQ} = 320\text{ mA}$, 56.2 W average output power, $f = 2180\text{ MHz}$. 3GPP WCDMA signal: 3.84 MHz channel bandwidth, 10 dB PAR at 0.01% CCDF.

Characteristic	Symbol	Min	Typ	Max	Unit
Gain	G_{ps}	18	19	—	dB
Drain Efficiency	η_D	35	38	—	%
Adjacent Channel Power Ratio	ACPR	—	-29	-26	dBc
Output PAR at 0.01% probability on CCDF	OPAR	6.4	7.0	—	dB

All published data at $T_{CASE} = 25^\circ\text{C}$ unless otherwise indicated

ESD: Electrostatic discharge sensitive device—observe handling precautions!



DC Characteristics

Characteristic	Conditions	Symbol	Min	Typ	Max	Unit
Drain-source Breakdown Voltage	$V_{GS} = -8\text{ V}$, $I_D = 10\text{ mA}$	$V_{(BR)DSS}$	150	—	—	V
Drain-source Leakage Current	$V_{GS} = -8\text{ V}$, $V_{DS} = 10\text{ V}$	I_{DSS}	—	—	4.5	mA
Gate Threshold Voltage	$V_{DS} = 10\text{ V}$, $I_D = 32\text{ mA}$	$V_{DSX(th)}$	-3.8	3.0	-2.3	V

Recommended Operating Conditions

Parameter	Conditions	Symbol	Min	Typ	Max	Unit
Drain Operating Voltage		V_{DD}	0	—	50	V
Gate Quiescent Voltage	$V_{DS} = 48\text{ V}$, $I_D = 320\text{ mA}$	$V_{GS(Q)}$	-3.4	-3.0	-2.5	V

Absolute Maximum Ratings

Parameter	Symbol	Value	Unit
Drain-source Voltage	V_{DSS}	125	V
Operating Voltage	V_{DD}	55	V
Gate-source Voltage	V_{GS}	-10 to +2	V
Gate Current	I_G	32	mA
Drain Current	I_D	12	A
Junction Temperature	T_J	225	°C
Storage Temperature Range	T_{STG}	-65 to +150	°C

Operation above the maximum values listed here may cause permanent damage. Maximum ratings are absolute ratings; exceeding only one of these values may cause irreversible damage to the component. Exposure to absolute maximum rating conditions for extended periods may affect device reliability. For reliable continuous operation, the device should be operated within the operating voltage range (V_{DD}) specified above.

Thermal Characteristics

$T_{CASE} = 70^\circ\text{C}$, 56.2 W (CW), 48 V, $I_{DQ} = 320\text{ mA}$, 2170 MHz

Characteristic	Symbol	Value	Unit
Thermal Resistance	$R_{\theta JC}$	1.1	°C/W

Ordering Information

Type and Version	Order Code	Package and Description	Shipping
GTVA212701FA V2 R0	GTVA212701FA-V2-R0	H-87265J-2, single-ended, earless flange	Tape & Reel, 50 pcs
GTVA212701FA V2 R2	GTVA212701FA-V2-R2	H-87265J-2, single-ended, earless flange	Tape & Reel, 250 pcs



Typical Performance (data taken in Wolfspeed production test fixture)

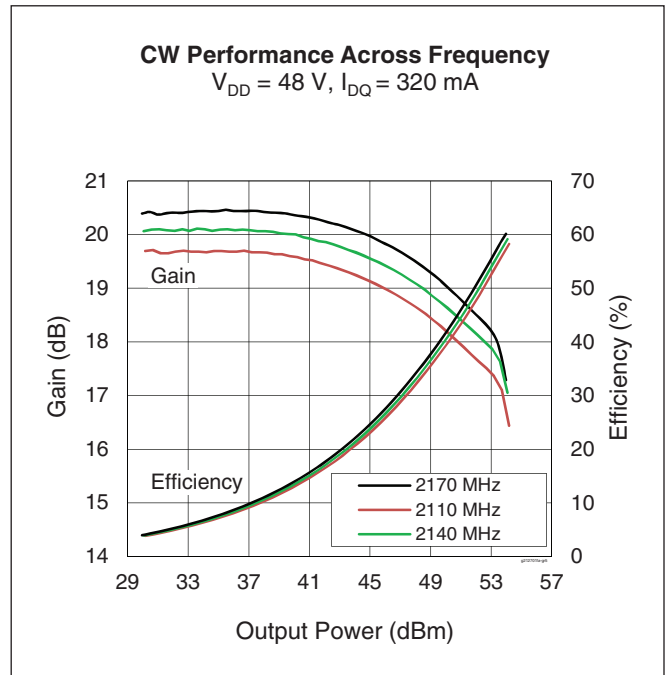
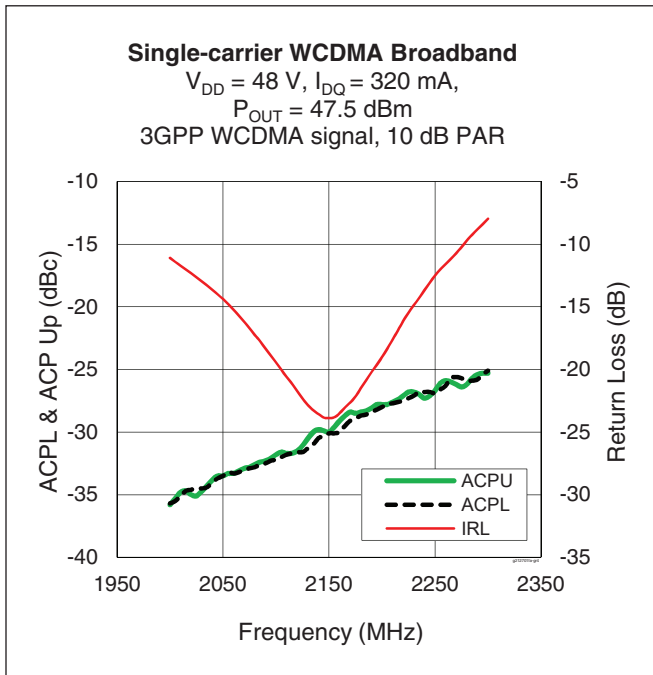
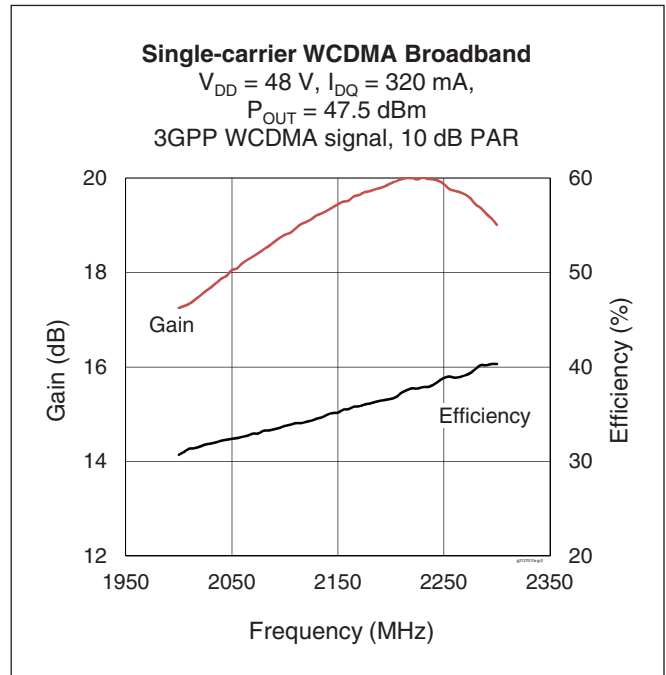
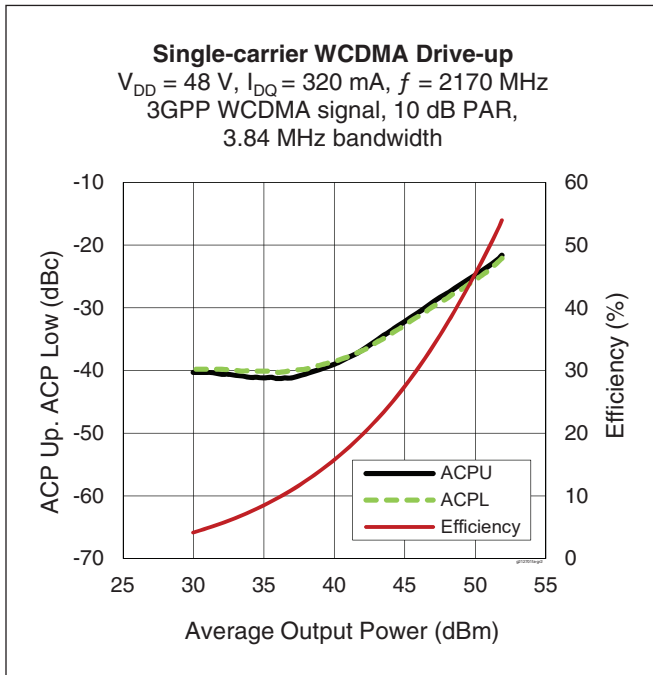

Typical Performance (cont.)

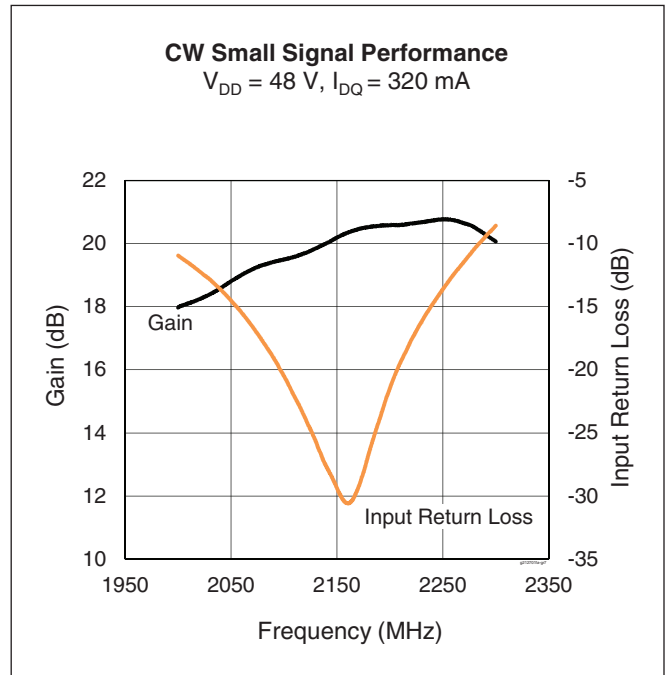
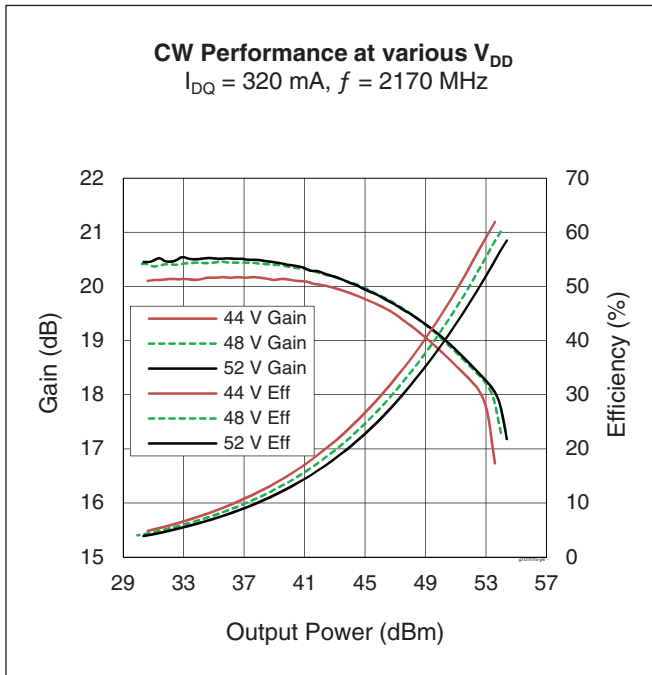

Load Pull

Pulsed CW signal: 10 μsec , 10% duty cycle; $V_{DD} = 48 \text{ V}$, $I_{DQ} = 300 \text{ mA}$

Class AB		P _{3dB}									
		Max Output Power					Max Drain Efficiency				
Freq [MHz]	Z _s [Ω]	Z _l [Ω]	Gain [dB]	P _{3dB} [dBm]	P _{3dB} [W]	η_D [%]	Z _l [Ω]	Gain [dB]	P _{3dB} [dBm]	P _{3dB} [W]	η_D [%]
2110	6.38 - j6.61	3.01 - j3.1	17.28	55.72	373.2	67.5	3.01 - j1.41	18.57	54.74	297.6	73.9
2170	4.78 - j4.24	3.01 - j3.1	17.37	55.71	372.3	68.8	3.13 - j1.84	18.55	54.78	300.7	73.2
2200	4.09 - j4.3	3.01 - j3.1	16.97	55.80	380.2	65.6	3.08 - j1.97	18.6	54.88	307.6	74.7



Reference Circuit tuned for 2110 to 2200 MHz

DUT	GTVA212701FA V2
Reference Circuit Part No.	LTN/GTVA212701FA-V2
PCB	Rogers 4350, 0.508 mm [.020"] thick, 2 oz. copper, $\epsilon_r = 3.66$
Find Gerber files for this reference circuit on the WolfSpeed Web site at http://www.wolfspeed.com/RF	

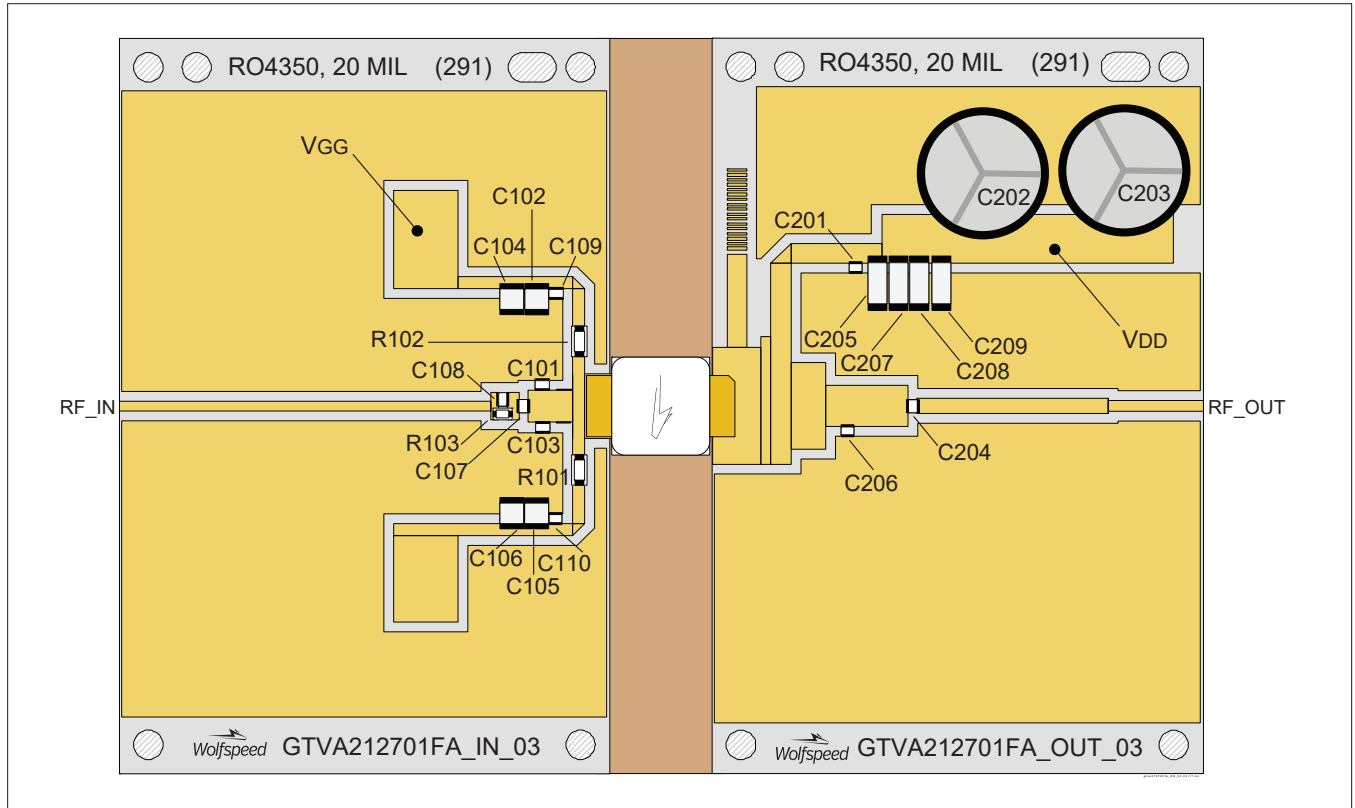

Reference circuit assembly diagram (not to scale)



Reference Circuit (cont.)

Components Information

Component	Description	Manufacturer	P/N
Input			
C101	Capacitor, 2 pF	ATC	ATC800A2R0BT250XT
C102, C104, C105, C106	Capacitor, 10 μF	Taiyo Yuden	UMK325C7106MM-T
C103	Capacitor, 0.2 pF	ATC	ATC800A0R2BT250XT
C107	Capacitor, 15 pF	ATC	ATC800A150GT250XT
C108	Capacitor, 12 pF	ATC	ATC800A120JT250XT
C109, C110	Capacitor, 24 pF	ATC	ATC800A240JT250XT
R101, R102	Resistor, 10 ohms	Panasonic Electronic Components	ERJ-8GEYJ100V
R103	Resistor, 10 ohms	Yageo	RC0805JR-0710RL
Output			
C201, C204	Capacitor, 24 pF	ATC	ATC800A240JT250XT
C202, C203	Capacitor, 220 μF	Panasonic Electronic Components	ECA-2AHG221
C205, C207, C208, C209	Capacitor, 10 μF	TDK Corporation	C5750X7S2A106M230KB
C206	Capacitor, 0.6 pF	ATC	ATC800A0R6BT250XT

Pinout Diagram (top view)

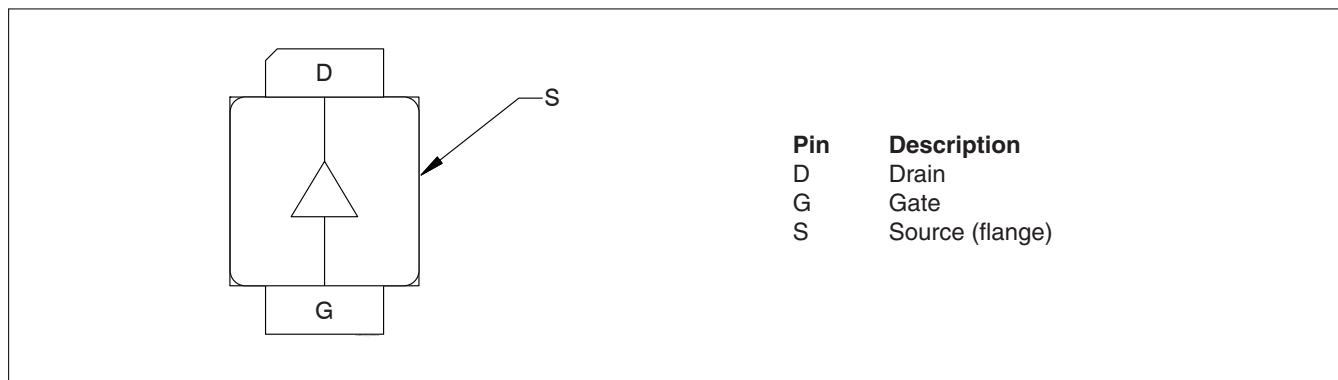

Package Outline Specifications

